



TECHNICAL SUMMARY



TECHNICAL SUMMARY

TABLE OF CONTENTS

Introduction	1
The Enclosure	1
The Drivers	2
Let's Begin With The Low Frequency Transducer (Woofers) ..	3
How Woofers Work ...	4
How To Make Woofers Work Better	5
The Technical Aspects	5
The Mid-Bass Coupler	6
The New High Energy EMIM™ Midrange	6
The New High Energy EMIT™ Tweeter	8
The Dividing Networks	8
Crossover Network/Speaker Binding Posts	10
Impulse Response	10
A Means To An End	10
Helpful Tips On How To Evaluate A Speaker System	10

INTRODUCTION

Infinity's new Renaissance Series embodies a number of innovative engineering principles which make these speakers distinctive and set them apart from other quality speaker systems. It is the purpose of this semi-technical paper to present these concepts in an informative and easy-to-understand manner, and it is our hope this information will give you insight into why we feel these speakers are among the best speakers Infinity has ever produced.

Since the introduction of the now legendary ServoStatik 1 system over 23 years ago, Infinity has firmly advocated planar drivers for the reproduction of midrange and high frequencies. Virtually every high-end Infinity speaker has included planar drivers to achieve super-fast transient response combined with low distortion and extended, ultra-linear frequency response. Over the years, Infinity's planar drivers have been significantly refined to optimize all performance parameters -- making them unique and better sounding than conventional drivers. Three years of intensive research into new materials and methods of production have resulted in the completion of two new high energy planar drivers which are the focal point of the new Infinity Renaissance Series. A newly designed High Energy EMIM™ midrange driver which offers greater speed (transient response) and lower distortion than previous designs is employed in both Infinity Renaissance speaker systems. The new High Energy EMIM couples to a completely redesigned High Energy EMIT™ tweeter that is more linear, responds much faster to transients, and has lower distortion than previous versions of this now famous tweeter. These two planar drivers have been carefully matched to a dual voice coil Infinity/Watkins woofer which permits the system to extend its bandwidth a half octave below what could be achieved with a standard bass driver within the same enclosure size.

THE ENCLOSURE

IT'S MORE IMPORTANT TO MUSICAL INTEGRITY THAN YOU MAY THINK.

The prime directive for a speaker enclosure is that it must look good and blend with any type of room decor. But it doesn't stop there. The enclosure plays an important role in how the speaker will sound. In fact, the role of the enclosure is as important as the transducers, crossover, or any other part of the system. The enclosure must be structurally rigid and inert so it does not flex or vibrate under the pressure created by the drivers (especially the woofer) when reproducing music. A vibrating enclosure produces spurious resonances which, when combined with music, detract from the musical experience. At times, these resonances are minute but experience tells us that even so, they can seriously degrade the harmonic structure of voice and music.

There are two main sources of enclosure vibration:

- 1) The reacting force created by the movement of the driver's voice coil and cone mechanism working in response to the input signal. These vibrations created by the moving mechanism are transmitted directly to the speaker's frame which in turn transmits them to the enclosure to which the driver is fastened. (Refer to Diagram 1.)

DIAGRAM 1:

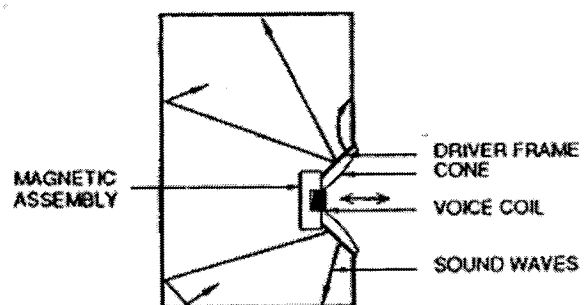

- 2) Sound pressure waves formed within the enclosure are created by the moving cone as it responds to the input signals. This type of spurious resonance can generally be damped

by using dacron or similar material inside the enclosure. The choice of the proper material and density of the material is of critical importance for the proper absorption of unwanted energy. (Refer to Diagram 2.)

DIAGRAM 2:

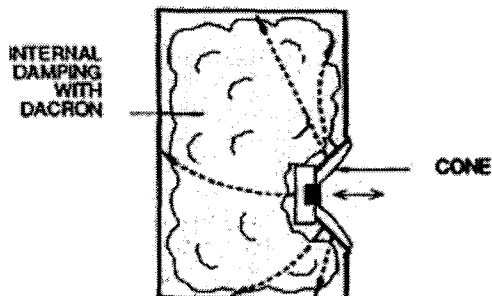

The enclosure must be constructed so it is solid and cannot respond to the pressure waves generated by the drivers. By the use of special materials and strong internal bracing, unwanted resonances and vibrations can be substantially minimized so they will not interfere with the sound emanating from the speakers.

Renaissance enclosures are engineered with close adherence to all of the basic principles of proper enclosure design. Nothing was overlooked or treated as unimportant in creating these exceptionally rigid, well-damped, virtually non-resonant enclosures.

Another important element in speaker enclosure design is the reduction of the ill effects created by diffraction, a form of distortion which occurs when higher frequency sound waves reflect from structural discontinuities of the enclosure. These spurious reflections reach the listener at different time intervals than the directed sound, resulting in blurred, muddied sound. Spaciousness is diminished and the harmonic structure of voice and music can be severely colored due to this time discontinuity. (Refer to Diagram 3.)

Infinity Renaissance enclosures have been specifically designed to reduce time smearing (blurring of the sound) caused by diffraction. The front grille is on the same plane as the midrange and high frequency drivers resulting in a smooth,

DIAGRAM 3:

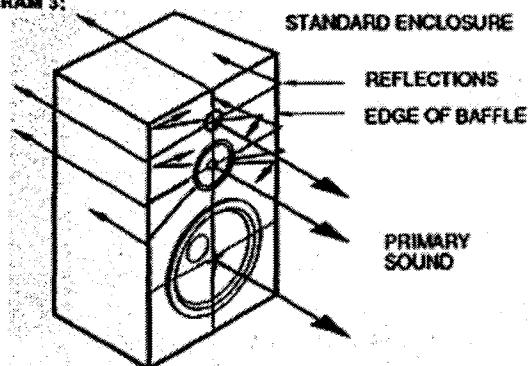

DIFFRACTION FROM FRONT BAFFLE, EDGES AND SIDES OF ENCLOSURE CREATE REFLECTIONS WHICH CAUSE SMearing OF THE SOUND

seamless transition between the drivers and grille. The corners of the enclosure are rounded and taper sharply to the rear, and the front grille mounting board is also rounded permitting a smooth joining to the enclosure. This enables higher frequencies to travel unimpeded to the rear where they are dissipated. By paying careful attention to all of these critical details, the energy radiating into the listening area is extremely clean, coherent, and transparent with clearly defined localization of soloists and instruments. (Refer to Diagram 4.)

DIAGRAM 4:

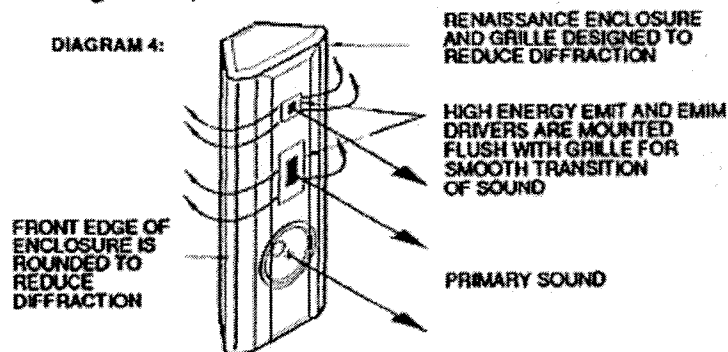

Infinity Renaissance Series speakers are mounted on three spikes, providing a stable and acoustically isolated platform that couples the speaker to the floor for cleaner, more transparent sound.

THE DRIVERS

Drivers are reasonable and acceptable compromises in many operating areas; however, this is not to say that virtually any of these areas cannot be improved by the use of new materials and innovative design techniques. Infinity has

always felt that what was acceptable a few years ago may no longer be acceptable today. The search for better designs must proceed on a continuous basis, and it is for this reason Infinity developed its own technological advances to solve inherent problems in drivers. It was necessary to do so again in the design of the Infinity Renaissance Series. Our engineers examined existing driver technology to find a way to improve upon the accuracy of voice and music reproduction. Major emphasis was placed on the redesign of our highly respected planar drivers to make them faster, more linear, and capable of handling higher power. We also looked into the refinement of woofer technology that we had originally pioneered many years ago -- the dual voice coil Infinity/Watkins Woofer™, which was capable of definitive bass response but not without certain limitations. It was our goal to remove these limitations while simultaneously making the woofer faster, lower in distortion, and easier for the amplifier to drive.

LET'S BEGIN WITH THE LOW FREQUENCY TRANSDUCER (WOOFER)

The Infinity/Watkins Woofer is comprised of the following elements: (Refer to Diagram 5)

1. Magnet and magnet assembly
2. Dual voice coil assembly
3. IMG™ (cone)
4. Flexible suspension system
5. Die-cast frame

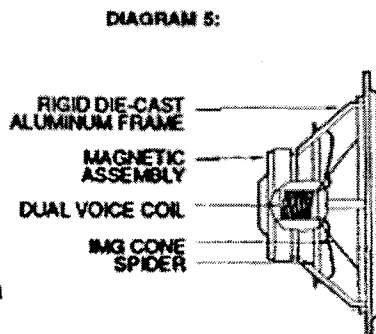

Of all these elements, only the dual voice coil is electrical in nature. The others are either magnetic or mechanical.

The magnet is essentially the heart of the entire magnetic structure and produces magnetic energy measured in gauss. It is encased within a magnetic return housing which forms the structural

support for the entire magnetic assembly. This structure must be extremely rigid in order to maintain the critical tolerance of the entire assembly.

Since the dual voice coil is the only electrical element in the woofer, it is connected to the power amplifier through the crossover network. The dual voice coil accepts the high current produced by the power amplifier. For this reason, the voice coils must be constructed of special material to prevent charring or burning under intensely dynamic conditions. The dual voice coils are wound one on top of the other and in turn mounted onto a specially constructed phosphor bronze former which can withstand high temperature.

The woofer cone driven by the voice coil converts mechanical into acoustic energy, and the conversion must be as efficient as possible to provide the greatest amount of acoustic power output for any given electrical power input. In a driver, the quality of the generated output signal is far more important than its quantity (power). In this regard, the cone has the greatest effect on how a driver will ultimately sound. It is primarily in this area that Infinity has achieved both sonic quality and high power handling by careful structural design of the cone and by using the proper materials to obtain the optimum ratio of strength-to-weight combined with excellent rigidity and damping.

During operation, the cone acts as a piston which is prone to excessive forces acting on it. If, by bending or wrinkling, the cone cannot precisely follow the signals fed to it, the final acoustic output will be distorted from the original source. The cone can be constructed from a vast number of different materials. The choice of material and the cone's mass, stiffness, and shape depend largely upon the application of the driver, its cost, and, more specifically, on what the designer wishes to accomplish.

Woofer driver cones are generally well-balanced at moderate excursions for approximately three octaves above their own free-air resonant frequency. Their operating region can be made

more linear by substituting polypropylene for paper or coated paper. This was achieved by Infinity in a pioneering series of drivers developed in the late seventies. However, in spite of the remarkable improvements in performance brought about by the use of polypropylene, Infinity felt that the overall performance of woofers warranted further development.

The Infinity/Watkins woofer is a totally new design -- from its dual voice coil to its injection molded cone. It was the goal of Infinity engineers to resolve many of the major performance problems still inherent in woofers in order to achieve a noticeable improvement in sonic quality.

To begin with, the dual voice coil woofer employs a die-cast aluminum frame rather than a stamped steel one which permits the frame to hold its structural integrity indefinitely. A die-cast frame is more inert than steel, and since it is also non-magnetic, efficiency is increased. It also results in less "ringing," a phenomenon created by vibrations and which interferes with sonic integrity.

Renaissance IMG woofer cones are comprised of a composite of a blend of polypropylene and graphite fibers molded according to a carefully calculated formula. Fabrication is done under extremely high heat and pressure (injection molded) which forms the cone to extremely tight tolerances. The graphite fibers are formed in a very precise pattern which flows from the center to the outer circumference. This results in excellent structural rigidity preventing cone bending throughout the frequency range of the woofer, even under the most taxing conditions. (Refer to Diagram 6.)

DIAGRAM 6:

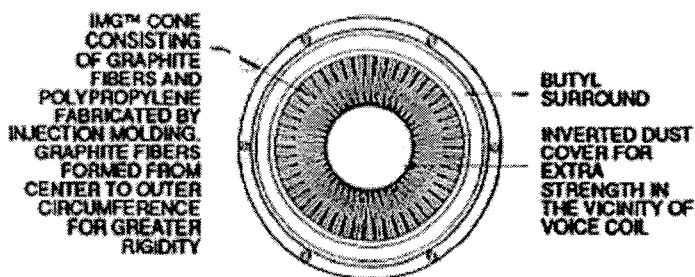

Superb structural rigidity of the cone material, combined with a specially tailored shape (which provides added strength to the moving piston), plus a newly-designed inverted dust cap (for added rigidity at the juncture of maximum force) enable the woofer to perform under high power conditions with minimum flexing. In addition, the combination of polypropylene and graphite fibers produces superior damping of unwanted resonances (breakup - eliminated by the polypropylene) and superb stiffness (no bending - accomplished by the graphite fibers). This new cone structure has less mass than previously used polypropylene-only cones permitting it to react more quickly to musical transients.

HOW WOOFERS WORK

Woofer design is somewhat of a dichotomy. The upper bass response - essentially flat by nature - is by itself simple and easy to control. Low bass response, however, from 100 Hz and below is another matter. Observation of a woofer while reproducing music will show the cone movement to be very small with upper bass notes, but becoming increasingly greater with the lower notes. Since the woofer cone must move back and forth to do its job, it compresses and expands the air inside the speaker enclosure (in an acoustic suspension enclosure) creating a resistance (air spring). However, in the low bass where the cone is moving much more, it encounters far greater resistance from the enclosed air, and more power is needed in order to overcome this resistance and reproduce the low bass. Although the strength of the woofer's motor can be increased to obtain extended low bass, the problem is that the controlling elements also affect upper bass response. In other words, the size of the woofer motor can be adjusted for extended low bass but this adversely affects the upper bass by changing its amplitude. For this reason, conventional design has always been a trade-off in balancing the performance between upper and lower bass, with the inherent limitation of less than optimum reproduction of those earth-shaking and soul-satisfying lowest bass notes.

HOW TO MAKE WOOFERS WORK BETTER

The Infinity/Watkins Dual-Drive Woofer offers a solution that is elegant, amazingly simple, and technologically correct. A secondary motor (in the form of a second voice coil) is inserted into the magnetic field and is energized only in the low bass. The strength of this secondary motor can be adjusted separately from the primary motor and with absolutely no ill effect on the upper bass range, thus allowing unprecedented low frequency response. The age-old problem of trade-offs in design are circumvented, and for the first time, performance is optimized throughout the entire low frequency spectrum of music. Bass energy is delivered with astonishing power and accuracy, laying down a solid foundation for the rest of the music. The Infinity/Watkins Woofer permits you to hear music with realism that is a delight to experience.

THE TECHNICAL ASPECTS

At resonance (30 to 60 Hertz in most speaker systems and right in the center of the low bass region), the compliance of the air in the enclosure resonates with the moving mass of the woofer cone and voice coil assembly. This causes the input impedance to rise in this region (typically to 15 or 20 ohms), and since the amount of amplifier power the woofer will accept is inversely proportional to impedance, this higher impedance reduces power intake. In the Infinity/Watkins woofer the secondary motor (voice coil) is designed for a lower impedance and allows more power intake resulting in more acoustic output and control in the resonance region.

Now, if this secondary motor were to be operated in the upper bass range as well, the acoustic output would increase there too, causing a peak in response and boomy sound, as well as making the impedance too low above 100 Hz. However, the secondary motor is allowed to operate only in the low bass region around

DIAGRAM 7:

EFFECT OF THE INFINITY/WATKINS DUAL VOICE COIL ON IMPEDANCE

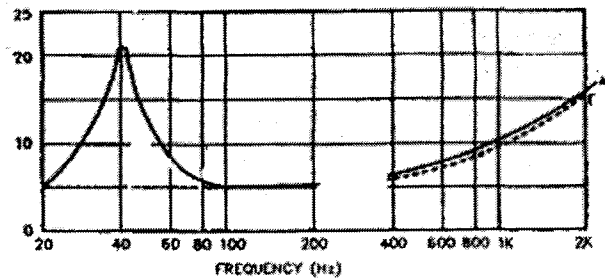

A - 10-INCH CONVENTIONAL LOUDSPEAKER (SINGLE VOICE COIL)

B - SAME LOUDSPEAKER USING INFINITY/WATKINS DUAL VOICE COIL DESIGN

NOTE: FLAT RESPONSE OF B AT RESONANCE.

SECOND VOICE COIL REDUCES RESONANCE, ALLOWING THE AMPLIFIER TO DELIVER MORE CURRENT DUE TO LOWER IMPEDANCE CREATED BY SECOND VOICE COIL. THIS ADDITIONAL CURRENT PERMITS DRIVER TO EXTEND LOWER IN RESPONSE.

DIAGRAM 8:

CONSTRUCTION OF THE INFINITY/WATKINS DUAL VOICE COIL

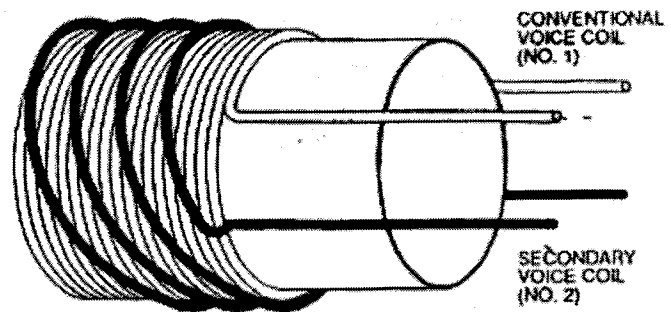
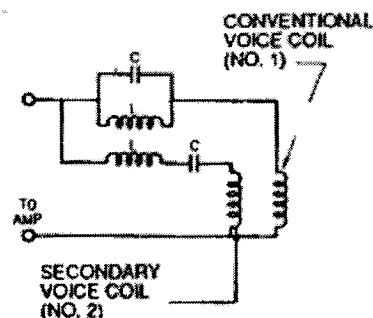

DIAGRAM 9:

OPERATIONAL DIAGRAM OF THE INFINITY/WATKINS DUAL VOICE COIL



resonance where the impedance was much too high anyway. This flattens the impedance peak at resonance and lowers it to a normal level providing the amplifier with a more correct and less reactive load with less phase shift. This is the kind of load amplifiers like to drive, and it allows optimum current and power to be delivered to the speaker. The overall result is flat and extended bass response

and better damping (less hangover) for more accurate transient response. The Infinity/Watkins Woofer delivers accurate and well-defined bass with unprecedented extension.

DIAGRAM 10:

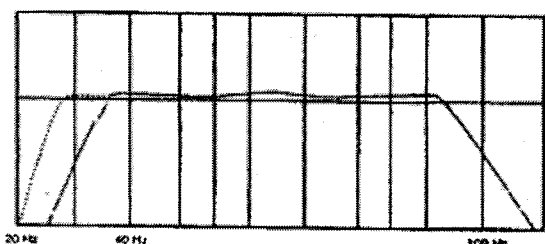

SOLID LINE (A) INDICATES SINGLE VOICE COIL WOOFER FREQUENCY RESPONSE. NOTE RAPID ROLL OFF AT RESONANT FREQUENCY OF 40HZ. DOTTED LINE (B) INDICATES ADDED LOW FREQUENCY RESPONSE DUE TO ACTION OF SECOND VOICE COIL IN WATKINS CONFIGURATION.

THE MID-BASS COUPLER

The Infinity Renaissance 90 utilizes a mid-bass driver that has been designed specifically to handle the extremely important frequency range of 200 Hz to 650 Hz where almost half of all musical energy appears (including all vocal fundamentals) and where most drivers are at their weakest operating point. This new IMG cone mid-bass driver has been designed to perform flawlessly over this critical frequency range and to deliver smooth transition between the Watkins woofer and the midrange planar driver. All frequencies below 200 Hz remain in the woofer where they are uniformly dispersed. Frequencies above 200 Hz are fed to the mid-bass coupler, allowing voices and instrumental textures to emerge with an airiness and clarity that is musically accurate.

The laws of science indicate that transducer dispersion into a listening area narrows as the wavelength of the sound approaches the diameter of the driver. A woofer which reproduces very low frequencies operates within its proper range until the wavelength reaches a point when dispersion begins to narrow. The large cone can no longer transfer higher frequencies into the listening area within a broad pattern. (Wavelength is the distance that a sound wave travels by the time the next waveform begins. The higher the frequency, the shorter the wavelength, therefore,

the shorter the time it takes to reach the next wavelength.) With any given size driver, as the frequency goes up, dispersion narrows. Crossing over into a smaller driver ensures that the wavelength remains long with respect to the radiating area. Dispersion, therefore, will not begin to narrow at higher frequencies.

The mid-bass coupler is ruggedly constructed utilizing a die-cast aluminum frame which is stronger, more rigid, and better damped than a stamped frame. The cone is a composite of graphite and polypropylene in a special formulation which results in excellent transient response, low distortion, and high power handling. The IMG cone provides unprecedented stiffness and damping which enables the driver to deliver this high level of performance. A rubber surround is used for optimum edge termination and long life. A long throw motor assembly assures low distortion and high power handling without dynamic compression.

THE NEW HIGH ENERGY EMIM™ MIDRANGE

There are several ways to proceed when designing midrange drivers. There is always the old and reliable cone, the horn-type driver, and the dome. All of these approaches have certain merits and are acceptable for all but the very best speaker systems. We examined midrange driver technology over twenty years ago and made the decision to develop our own driver which would deliver fast, clean response combined with low distortion and excellent power handling. These planar designs satisfied every performance requirement, however, they were very costly and difficult to build. Extensive research has gone into our planar designs over the past several years, and we have now found a way to remove some of the complexity from the driver, while retaining all its virtues. In fact, the new design offers higher efficiency, lower distortion, and greater speed than previous models. The new version of the Infinity High Energy EMIM™ features strong magnets (rare earth neodymium) in a push-pull

arrangement which greatly reduces harmonic distortion. The voice coil gap has been optimized, which, when combined with a strong magnetic field, results in higher output across the High Energy EMIM's entire frequency range. The diaphragm material is Kapton which is many times lighter than cones and domes and can withstand the heat created by loud signal levels. Kapton is also extremely lightweight which results in a midrange driver that is super-fast. Transient response is quicker than any midrange we have ever tested.

The new High Energy EMIM is operated within a relatively narrow frequency band which assures maximum dispersion within its operating range.

To guarantee the highest quality performance after many hours of use, the structure of the High Energy EMIM has been redesigned to prevent the driver from bending or warping under extreme temperature conditions. Furthermore, the newly designed five layer laminated diaphragm has been suspended within its rigid metal housing in a manner to prevent stretching and wrinkling. By maintaining uniformity, even under adverse conditions, the new High Energy EMIM retains its super-fast, lucid characteristics and provides this high level of performance over the course of many years.

Previous Infinity designs employed the EMIM as a dipole radiator which means that both the front and rear of the EMIM produced audio signals which were directed into the listening room. The front wave was directed at the listener while the rear wave bounced off the front wall of the listening room. This created a lifelike, deep stage effect; however, this type of design had problems which often affected the detail and focus of the sound. Since the room becomes an integral part of the speaker when a dipole is used, the room always plays an important role in how the speaker will ultimately sound. If room acoustics behind the speaker presented little or no problems, a dipole configuration generally sounded very dramatic and spacious. However, if room reflections were severe, the sound would smear and there would be

a loss of focus and harmonic clarity as well as overall balance anomalies.

The design goal of Renaissance was to reduce room interference as much as possible while still maintaining a high level of spaciousness and front-to-rear imaging. This required the rethinking of our conventional dipole approach by modifying it to something substantially easier to use and set up, and also be compatible with a variety of rooms. A great deal of experimentation took place in various listening rooms around the world, and it was decided that loading the High Energy EMIM into a highly damped transmission line was the correct way to proceed. The transmission line configuration removes rear wave reflections which in turn reduces distortion and makes the High Energy EMIM's forward sound cleaner and more focused. This approach preserves the front-to-rear image and side-to-side spaciousness which is so important to a totally musical system.

Diagram 11 shows the construction of the new High Energy EMIM. Simpler in mechanics than previous models, test procedures have been intensified to ensure uniformity and perfect operation under all possible conditions.

The new ultra-fast and highly efficient High Energy EMIM presents the amplifier with an easy load since it is virtually resistive in nature.

DIAGRAM 11:

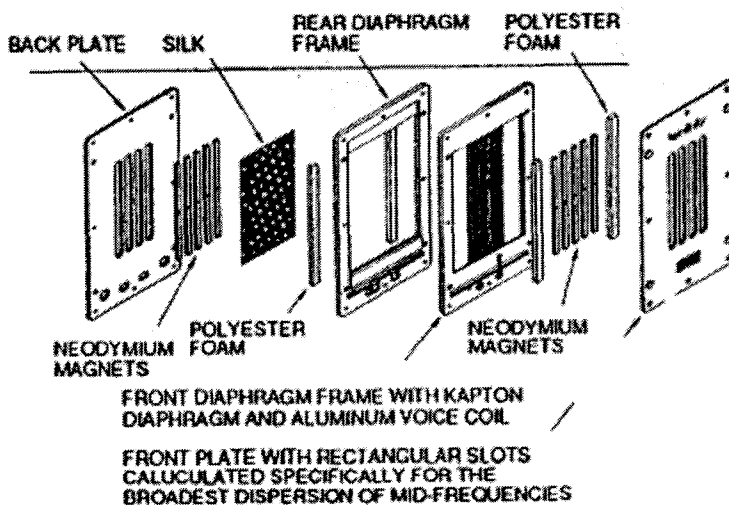

Diagram 11 shows the components of Infinity's new electromagnetic induction midrange driver (High Energy EMIM™). This new midrange driver delivers sheer transparency, clarity, and fine detailing of mid-band frequencies even at high sound pressure levels, but without the limited transient response of cones and domes. The voice-coil's large radiating area readily distributes heat to the air which permits the driver to handle high power. Sonic balance is exceptionally smooth, warm, delicate and transparent, with every nuance captured realistically. In short, this new midrange driver defines the state-of-the-art in transducer design and sonic musicality.

THE NEW HIGH ENERGY EMIT™ TWEETER

Both Infinity Renaissance models employ the newly-designed High Energy EMIT™ tweeter that combines an extremely light but rugged diaphragm constructed of Kapton (which is approximately ten times lighter than a conventional dome) plus rare earth neodymium magnets aligned in a push-pull configuration for maximum efficiency and minimum distortion. The lightness of the Kapton diaphragm and the superior magnetic strength of the neodymium magnets enable the High Energy EMIT to respond to 45kHz, an astonishingly broad range. Infinity has found that extending frequency response well beyond the normal hearing range provides greater speed and coherency within the musical range, which results in greater depth, clarity, and harmonic integrity.

The High Energy EMIT's new mechanical structure also permits the driver to be used at lower frequencies than previous EMIT drivers, enabling its speed and transient capabilities to become even more meaningful to the overall balance of the system. Crossing over the High Energy EMIT lower also results in better dispersion because the EMIM midrange driver is removed from the system before it can acoustically beam from the shorter wavelengths generated at higher frequencies.

The High Energy EMIT also features newly designed vertical apertures that provide wide dispersion and permit high frequencies to spread evenly and broadly throughout the listening area. When the High Energy EMIT was in its early design stages, Infinity engineers had the choice of employing Kapton, mylar, or a super light metal diaphragm. After many hours of measurements and listening, the decision was made to use Kapton because of its light weight, strength, and excellent immunity to heat. Metal diaphragms, although quite light, have a tendency toward ringing and have to be heavily damped in order to reduce the ringing. Even if the ringing occurs well beyond the range of hearing, the influence of this annoying phenomenon reflects back into the musical range manifesting itself as an edginess which masks the true harmonic content of voice and musical instruments.

Due to its unique design and high quality component parts, the High Energy EMIT guarantees effortless transient response and low distortion in the upper ranges of human audibility, a range that less effective tweeters must strain to reach.

DIAGRAM 12:

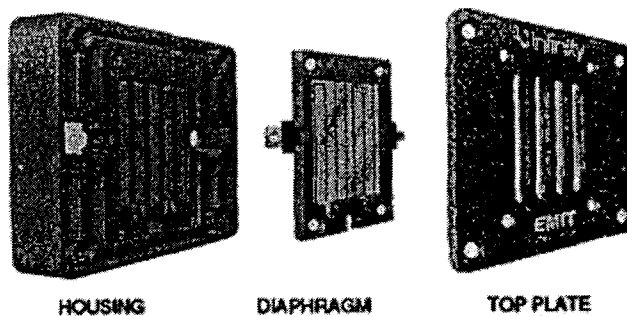

THE DIVIDING NETWORKS

In a multiple speaker system where each driver has been designed expressly to deliver optimum power, frequency response, minimum distortion, and wide dispersion, the crossover network is used to divide the audio frequency energy into appropriate frequencies to suit the operation of the individual drivers. If the various crossover points are not set within pinpoint accuracy and

more than the required energy is fed to any particular driver, frequency response variations, distortion, and even overheating can occur if the drivers are driven to power levels beyond their normal capacity. Furthermore, if the crossover network is not top grade in all parameters, efficiency can be reduced substantially due to insertion loss (the dissipation of much of the amplifier power fed to the network).

A single capacitor or inductor provides gradual attenuation with frequency as the range of undesired frequency components is approached. Although it is not always advisable to utilize a very narrow crossover range using steep slopes, simple reactive/capacitive circuits are generally too broad in the crossover region to perform properly. This is the inexpensive and generally improper way to cross over drivers. Instead, a combination of steeper low pass (for the woofer), band pass (for the midrange), and high pass (for the tweeter) filter circuits are usually employed. With this type of circuit (refer to Diagram 13), much greater attenuation can be achieved near the crossover frequency than is possible with a simple single capacitor and inductor configuration.

DIAGRAM 13:

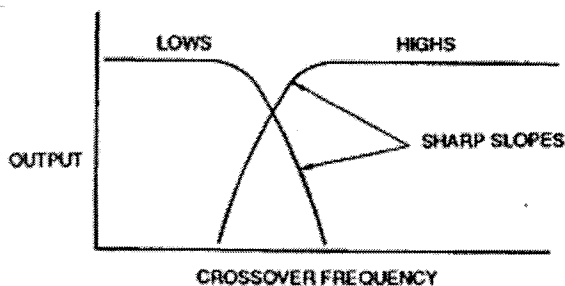

The dividing networks used in Infinity's Renaissance speakers employ specially selected components to ensure uniformity and guarantee close adherence to the original designs, even when performing at high power levels. Capacitors were chosen for their sonic quality as well as their reliability over long periods of operation. Highest quality polypropylene capacitors are used in the

signal path of the High Energy EMIM and High Energy EMIT to eliminate high frequency stridency often created by lower quality capacitors. Inductors are precision adjusted on a bridge for close adherence to specifications. All wiring in the low frequency section of the network is heavy gauge and is point-to-point wired for optimum transfer of high current. The low frequency crossover is isolated from the midrange and high frequency sections in order to eliminate magnetic close coupling and to maintain the musical integrity of their signals. Wiring is kept short and is routed for low loss in order to preserve musical integrity.

The original crossover designs were primarily worked out on a computer using a MLSSA FFT program, swept sine and pink noise, and were later "tweaked" in several different sound rooms in real time to determine how they performed in an actual home environment. A computer can outline the basic design parameters of a network according to various fixed formulae, but it takes careful listening to the complete system to determine its sonic virtues. Each time a component is changed, the system must go through a subjective listening test to ensure cohesiveness and to preserve musicality. Non-linear time delay and excessive dynamic distortion can smear the sound, shift the depth of the stereo image, and create annoying sonic distortions.

Careful listening revealed that the High Energy EMIT tweeter had to be rolled off at 24dB/octave which meant the inclusion of a fourth order Linkwitz-Riley dividing network. The advantages of this type of sharp rolloff are numerous:

- More symmetrical vertical polar response

- More rapid attenuation in each driver's stop bands yields minimized audibility of the diaphragm's breakup as well as other distortions

- Each driver is attenuated 6dB at the crossover point, as opposed to 3dB down for other slopes, producing a flat overall amplitude response. This reduces the power requirement to the tweeter at the crossover.

CROSSOVER NETWORK/ SPEAKER BINDING POSTS

The input terminals for all three models are heavy duty binding posts using brass with gold plating for optimum contact and minimal corrosion, even under adverse atmospheric conditions. The screws are massive and can accept heavy wire or special connectors. The brass, gold plated jumpers are extra thick to ensure maximum contact and the best transfer of signal between the upper and lower posts (which are used individually only in a bi-amplification or bi-wiring arrangement).

IMPULSE RESPONSE

A speaker's ability to respond to transients can be shown by impulse response testing. A pulse of known voltage is fed to the speaker and a plot can be drawn to indicate how rapidly the speaker responds to the pulse and then tapers off to zero. Theoretically, there should not be an overshoot. If an overshoot in the response is noted, it should be damped very quickly. Excessive overshoot usually results in strident high frequency response which is non-musical and fatiguing.

Extensive MLSSA FFT (Maximum Length Sequence System Analyzer) testing was performed on the new Renaissance Series, and when compared to several well-known, highly regarded speakers, both Renaissance models indicated faster damping with less overshoot. (Refer to Diagram 14a and 14b.)

DIAGRAM 14A:

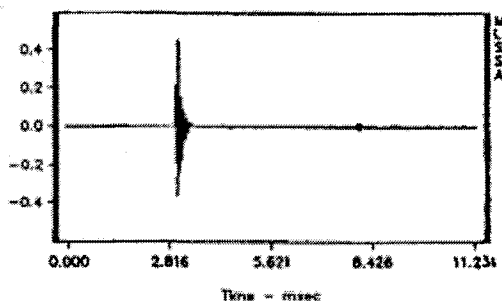

IMPULSE RESPONSE OF A POPULAR, HIGHER-PRICED
COMPETITIVE SPEAKER SYSTEM

DIAGRAM 14B:

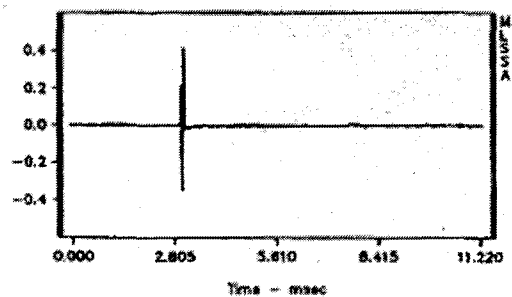

IMPULSE RESPONSE OF RENAISSANCE SPEAKER
SYSTEM (NOTE SUPERIOR DECAY)

A MEANS TO AN END

The sum of all of this technical innovation is a notably more accurate recreation of the musical event. Infinity did not design the Renaissance Series merely for technology's sake. These speakers have been designed to reproduce music accurately and demandingly. They were voiced using a variety of different listening environments and many trained listeners throughout the world. Choosing the proper musical balance did not come quickly or easily. During this extremely difficult and stringent testing period, both Renaissance Series speakers were compared not only with competitive models but with our own highly acclaimed Beta and IRS V.

HELPFUL TIPS ON HOW TO EVALUATE A SPEAKER SYSTEM

If you are a lover of classical music,
then try this --

There isn't a cut and dry way to audition a speaker. Most knowledgeable listeners, however, use similar methods (or a combination of methods) that seem to prove useful in determining a speaker's performance. Some use CDs, while others insist on LPs, and a few lucky ones use second or third generation master tapes. There are still others who use only white and pink noise for preliminary

listening to determine the accuracy of a system and later move on to records or CDs.

Most trained listeners usually begin their speaker tests by playing classical recordings which were produced with very few microphones. They can tell which recordings fit into this category because there is greater depth and side-to-side spaciousness, without unrealistic highlighting of certain instruments. Fewer microphones also generally result in better imaging. These virtues are easy to identify and help greatly in the judgment of a speaker's performance.

The experienced listener usually begins a test by playing a familiar recording. The first few minutes are spent relaxing with the music, savoring the performance and melody which permits the hearing mechanism to become acquainted with the structure and character of the sound. After this is accomplished, the next step is to divide mentally the sound spectrum into four or five segments: bass, mid-bass, midrange, upper midrange and highs. Once the test begins, the listener will listen to only one segment of the audio spectrum at a time.

Bass frequencies can be judged by the power and smoothness of this spectrum. Tympani, and most especially the bass drum, must emerge with a sharp, clean thud. It should not boom. Boominess in the lower frequencies does not always indicate a poorly designed system, and it is for this reason that placement of the speakers in the listening environment is so important. At times, moving the speakers or listening position a few inches can result in an improvement in sound. Poorly defined and boomy bass can also be the result of a poorly designed amplifier or preamplifier, especially if the power amplifier does not have adequate current capability to drive the lower frequencies. Good bass response should provide the listener with a physical presence that presses against the listener's body. It should be felt as well as heard, and it should be clean and well-defined.

It is easier to judge speaker performance by listening to midrange frequencies, especially when listening to a female vocalist. Listen to the voice; not the instruments. Does the voice sound hollow, honky or nasal? Is it constricted? Is there air around the singer or does she sound like she is singing in a dead room? Unfortunately, some listeners react positively to "nasalness" because it falsely produces midrange projections. This type of forwardness is unnatural and must be avoided. Good speaker systems are very linear in the midrange and, often as not, sound almost dull by comparison with speakers that emphasize this frequency range. Midrange response should be airy, transparent, and fast, but it should not project audibly beyond the boundaries of the musical spectrum.

Strings (also brass, female voice in the higher registers and certain sections of the tympani) are the most revealing instruments for judging high frequency performance. The sound character should be smooth and silky with a lush sheen but still adequately crisp to denote precise movement from one to another. Highs should not zing or sound strident. This is the range where superb tweeters will outperform their less potent counterparts because they will reproduce this range with amazing transient response and clarity, but without harshness.

A word of caution. Many amplifiers, preamplifiers, and most especially CD players often experience difficulty in the frequency range of 1,000 to 5,000 hertz, causing music to become brittle and excessively strident. It is often difficult to distinguish if the speaker or the associated equipment is causing the harshness. Ask the dealer to demonstrate the system using different components to determine if the high frequency harshness can be diminished or eliminated.

If popular music is your favorite, follow these suggestions for identifying good sound.

Five ways to know a good speaker when you hear it:

- Intelligibility:** This refers to the ability to understand the words of a vocalist and is a definite indication of speaker accuracy. A lack of intelligibility denotes poor midrange performance. Since the fundamentals of voice (as well as almost all instruments) begins in the midrange, poor performance in this frequency spectrum means equally inaccurate reproduction of the entire harmonic structure.
- 2. Transient Response:** Excellent response to fast musical transients means you will hear the staccato beat of a drum roll not as a blur but as a fast series of rapid beats. You should be able to hear the same distinctiveness of individual beats or notes along with the percussive sounds of other instruments such as a harpsichord, piano, cymbals, and so on. The fast sound of a plucked string should also emerge with airiness and clarity. A transient is a sound that starts and stops very quickly, and this is what the speaker system must do in order to faithfully reproduce this type of sound. There should be no overhang or smearing.
 - 3. Spaciousness:** Most modern recordings are recorded and produced so they recreate the ambience and spaciousness of a live performance. Vocalists are generally recorded so they appear in the center stage between the speakers. Instruments should have air around them, and you should be able to visualize (judging from the sound) where they were situated when the recording was made. There should be a definite perception of front-to-rear depth and side-to-side width. Also, vocalists should be localized in one spot rather than float or sound as though the voice spans the entire distance from left to right.
 - 4. Balance:** Regardless of how wide a range of tones a speaker can reproduce, if the overall balance is unnatural (the bass is good but it overpowers the midrange and highs), it becomes tiring to listen to. The same holds true if the midrange is louder than the bass or highs or if the highs dominate the musical spectrum. A properly designed speaker has excellent balance throughout the entire musical range, and the listener will not tire trying to rebalance the spectrum in his mind. The sound should be smooth, but it must not lack clarity or any of the other virtues that a good speaker must possess. There should be cohesiveness across the entire audio spectrum which means that the sound produced by the speaker must not seem to emanate from individual drivers but from the entire speaker system as a single entity. This is critical to good listening.
 - 5. Sonic Quality:** Do voices and instruments sound right? Are they unnaturally dull or too bright? Are you hearing everything on the recording or are certain sounds hazy, veiled, or laid back? Is bass response crisp, solid, and well-defined, or is it overly prominent and boomy?

If the speaker you are evaluating can satisfy all or most of these requirements, then you've been listening to an accurate system.



We get you back to what it's all about. Music.

Because Infinity consistently strives to improve existing products, features, specifications, and prices are subject to change without notice.

©1991 Infinity Systems, Inc., 9409 Owensmouth Avenue, Chatsworth, California 91311 • (818) 407-0228 • FAX (818) 709-9486