

## SPECIFICATIONS

DIAMETER:	12" (305.0 mm)
SENSITIVITY (2.83 V @ 1 m):	92 dB
POWER HANDLING:	280 W <sub>RMS</sub>
FREQUENCY RESPONSE:	25 Hz ~ 2 kHz
NOMINAL IMPEDANCE:	5 OHMS
VOICE-COIL DIAMETER:	2.0" (50.7 mm)
DIMENSIONS:	

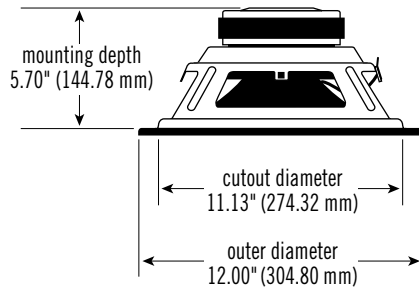

## THIELE-SMALL PARAMETERS

VOICE COIL DC RESISTANCE:	$R_{EVC}$ (OHMS) . . . . .	4.50
VOICE COIL INDUCTANCE @ 1 kHz:	$L_{EVC}$ (MH) . . . . .	1.00
DRIVER RADIATING AREA:	$S_D$ (IN <sup>2</sup> ) . . . . .	85.03
	$S_D$ (CM <sup>2</sup> ) . . . . .	551.00
MOTOR FORCE FACTOR:	$BL$ (TM) . . . . .	13.10
COMPLIANCE VOLUME:	$V_{AS}$ (FT <sup>3</sup> ) . . . . .	5.21
	$V_{AS}$ (LITERS) . . . . .	123.00
SUSPENSION COMPLIANCE:	$C_{MS}$ (μM/N) . . . . .	285.30
MOVING MASS, AIR LOAD:	$M_{MS}$ (GRAMS) . . . . .	98.65
MOVING MASS, DIAPHRAGM:	$M_{MD}$ (GRAMS) . . . . .	91.00
FREE-AIR RESONANCE:	$F_S$ (Hz) . . . . .	30.00
MECHANICAL Q:	$Q_{MS}$ . . . . .	5.50
ELECTRICAL Q:	$Q_{ES}$ . . . . .	0.49
TOTAL Q:	$Q_{TS}$ . . . . .	0.45
MAGNETIC-GAP HEIGHT:	$H_{AG}$ (IN) . . . . .	7.11
	$H_{AG}$ (MM) . . . . .	0.28
VOICE-COIL HEIGHT:	$H_{VC}$ (IN) . . . . .	22.61
	$H_{VC}$ (MM) . . . . .	0.90
MAXIMUM EXCURSION:	$X_{MAX}$ (IN) . . . . .	0.31
	$X_{MAX}$ (MM) . . . . .	7.75

## IMPEDANCE CURVE

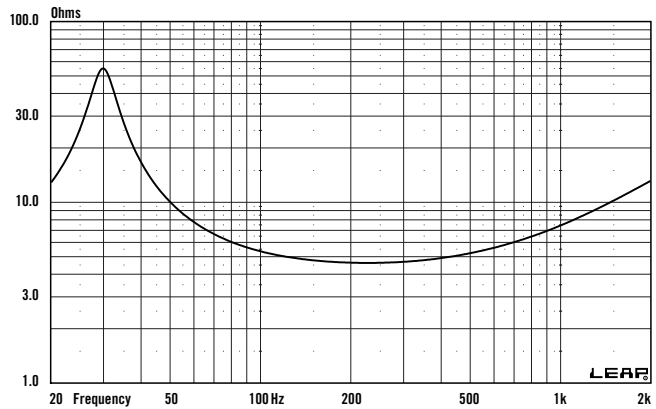

## INFINITE Baffle FREQUENCY RESPONSE @ 2.83 V

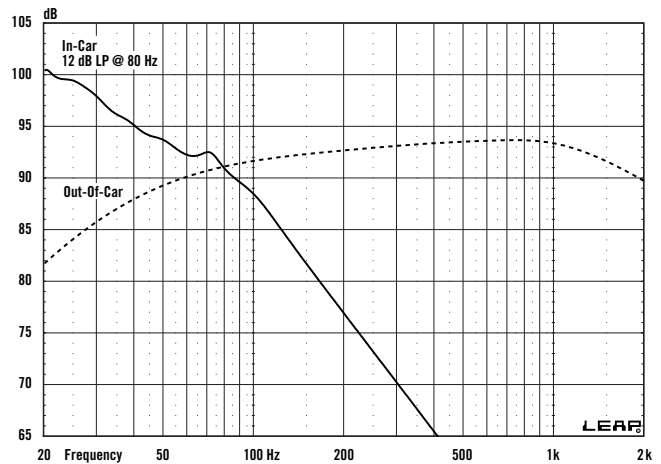

## INFINITE Baffle EXCURSION/GROUP DELAY @ 75 W

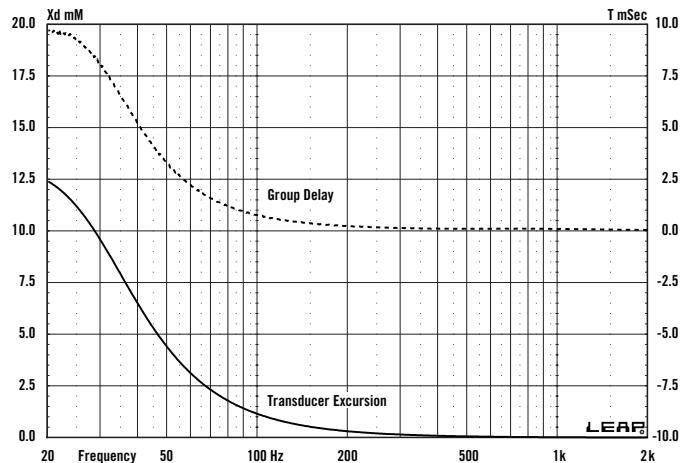

## SEALED BOX VOLUME

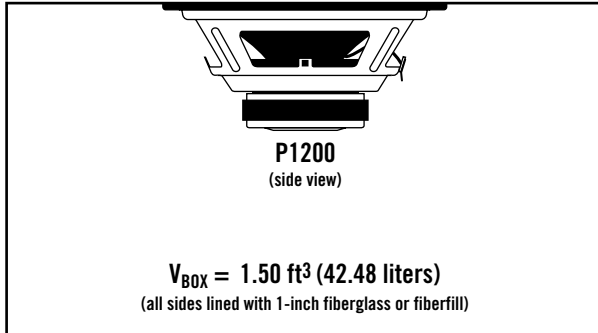

## VENTED BOX VOLUME

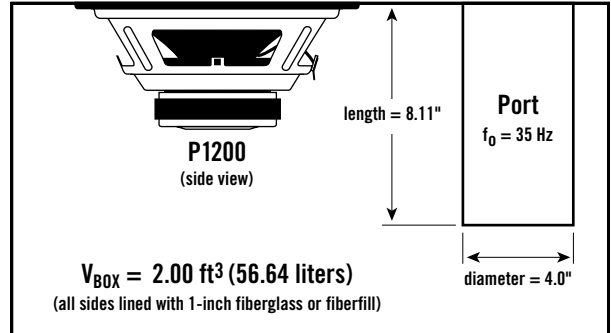

## SEALED FREQUENCY RESPONSE @ 2.83 V

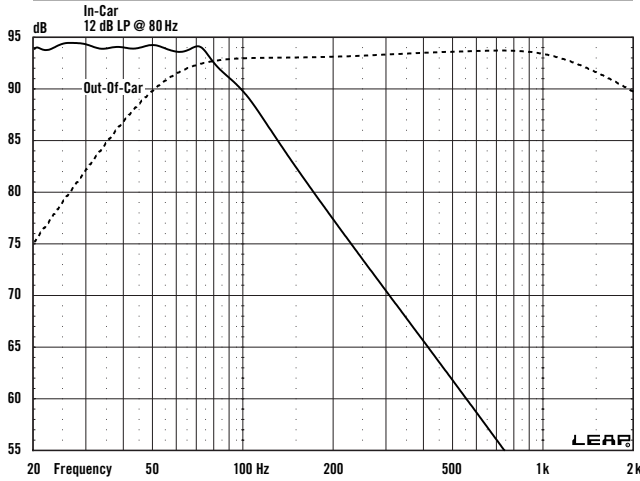

## VENTED FREQUENCY RESPONSE @ 2.83 V

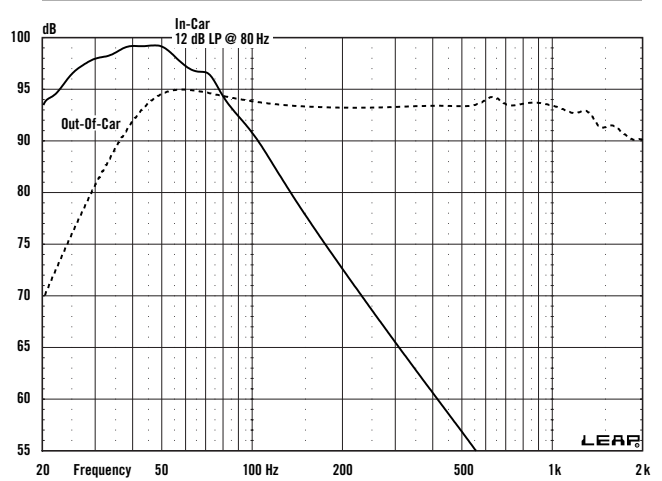

## SEALED EXCURSION/GROUP DELAY @ 225 W

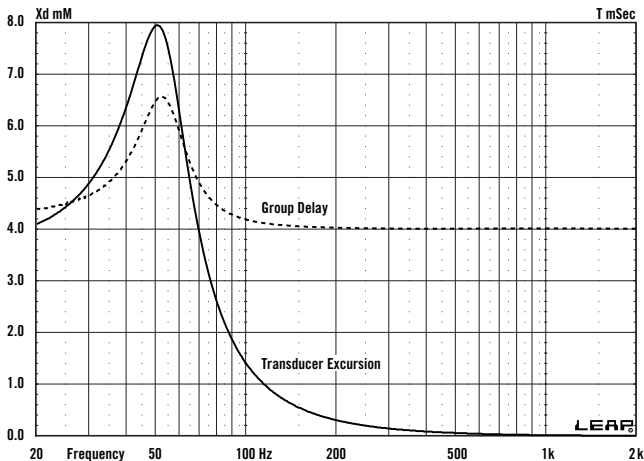

## VENTED EXCURSION/GROUP DELAY @ 350 W

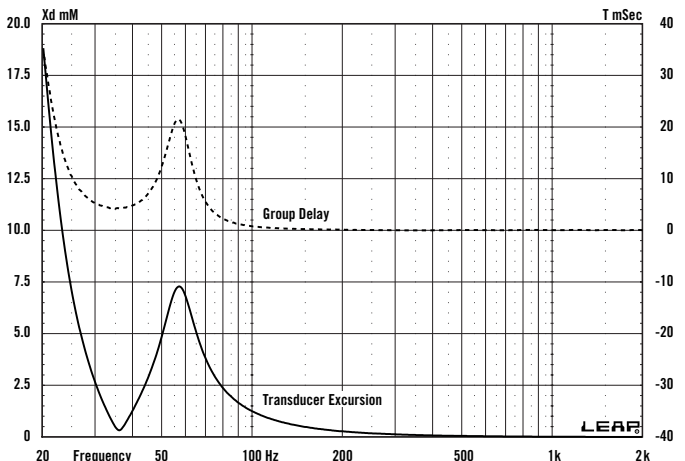

## SEALED BANDPASS BOX VOLUME

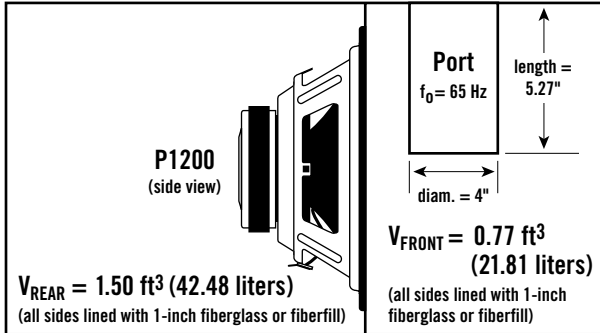

## SEALED BANDPASS FREQUENCY RESPONSE @ 2.83 V

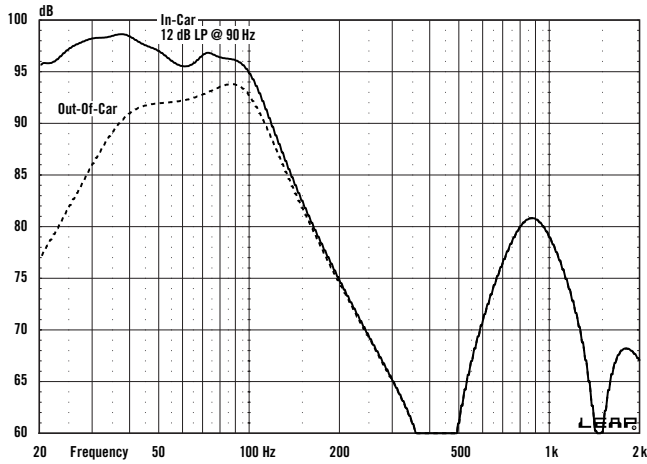

## SEALED BANDPASS EXCURSION/GROUP DELAY @ 200 W

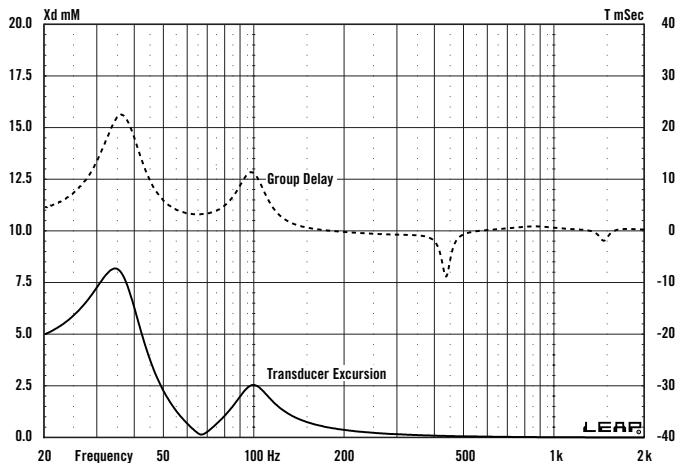

## NOTES