

**THANK YOU** for choosing a JBL Stadium subwoofer. These subwoofers are designed to suit a broad range of car audio applications and can be used in a wide variety of enclosure types to produce extended, powerful bass in a limited amount of vehicle space. To get the most performance from your new subwoofer, it is strongly recommended that you have a qualified professional install your subwoofer. Although this manual does provide general instructions about installing these Series subwoofers, it does not include enclosure construction details or exact installation methods for any particular vehicle. If you do not feel that you have the necessary experience, do not attempt the installation yourself, but instead ask your authorized JBL dealer about professional installation options.

Remember to keep your sales receipt in a safe place, along with this manual, so that both are available for future reference.

## WARNING

Playing loud music in a vehicle can hinder your ability to hear traffic and permanently damage your hearing. The maximum volume levels achievable by JBL speakers when combined with high-power amplification may exceed safe levels for extended listening. Using low volume levels is recommended when driving. JBL, Inc. accepts no liability for hearing loss, bodily injury, or property damage as a result of use or misuse of this product.

## REPRODUCING BASS IN VEHICLES

Depending on the size of your vehicle's interior listening space, reproduced bass frequencies below 80Hz will be boosted by nearly 12dB per octave as frequency decreases. This phenomenon, known as the vehicle's transfer function (or cabin gain), plays an important role in shaping the subwoofer's frequency response in your vehicle.

## SUBWOOFER ENCLOSURE TYPES

The subwoofers are designed to perform best in moderately sized sealed enclosures, vented enclosures and prefabricated band-pass enclosures. Infinite-baffle mounting is possible, but the subwoofer's mechanical power handling will be reduced because there will be no volume of air to stiffen the subwoofer's suspension and prevent overexcursion. If you choose infinite-baffle mounting, consider the RMS and peak power-handling ratings to be half of what is listed in the specifications in this manual.

You should choose an enclosure type based on the amount of cargo space you can devote to the enclosure, the amount of power you will use to drive your subwoofer(s), and your listening habits.

## SEALED ENCLOSURES

The air trapped inside a sealed enclosure is compressed when the subwoofer moves rearward and is rarefied when the subwoofer moves forward. In both cases, the air inside and outside the box will seek equilibrium by pushing and pulling on the subwoofer cone. The result is a stiffer suspension when compared to the subwoofer operating in free air. This means that the subwoofer's cone will be harder to move at low frequencies, a condition which protects the subwoofer from physical overexcursion, but requires more power than other designs to achieve a given acoustic output.

## SEALED-ENCLOSURE PERFORMANCE ADVANTAGES

- The in-vehicle performance will have the flattest overall frequency response.
- The in-vehicle response will have the widest bandwidth. (Usable low-frequency response inside the vehicle will be below 20Hz.)
- An optimum sealed enclosure will always be smaller than an optimum enclosure of another type.

## SEALED-ENCLOSURE PERFORMANCE TRADE-OFFS

- An optimum sealed enclosure will have lower overall efficiency than an optimum enclosure of another type.
- A subwoofer in an optimum sealed enclosure will require more amplifier power to achieve a given acoustic output than in an optimum enclosure of another type.

## SEALED-ENCLOSURE CONSTRUCTION

Sealed-enclosure construction is straightforward and forgiving of errors in volume calculation, but air leaks should be avoided. Use medium-density fiberboard (MDF), glue and screws to construct the enclosure, and seal all joints with silicone caulk.

## RECOMMENDATION

Subwoofers in sealed enclosures are recommended for enthusiasts who prefer accurate music reproduction and flat frequency response, for those who have a smaller space to devote to a subwoofer enclosure, and for those who have plenty of amplifier power devoted to driving the subwoofer. The sealed-enclosure design indicated in this manual represents the best compromise between low-frequency extension and flat response.

## VENTED ENCLOSURES

A vented enclosure acts like a sealed enclosure at frequencies above its tuned (resonance) frequency. At resonance (which is defined by the vent), the vent produces the majority of sound – the subwoofer cone is nearly stationary while the air inside the vent vibrates. This provides greater mechanical power

handling at and above resonance, but reduced mechanical power handling below resonance. Since the subwoofer cone and voice coil don't move much at resonance, airflow across the voice coil is minimized and thermal power handling is reduced slightly at resonance.

Vented enclosures provide better efficiency in the 40Hz – 60Hz range, at the expense of sound output in the lowest octave (below 40Hz). The use of an infrasonic filter is recommended with vented enclosures. An optimum vented enclosure for a Series subwoofer is larger than an optimum sealed enclosure.

## VENTED-ENCLOSURE PERFORMANCE ADVANTAGES

- An optimum vented enclosure has greater efficiency and higher output in the 40Hz – 60Hz range than an optimum sealed enclosure.
- An optimum vented enclosure provides a greater sensation of bass than an optimum sealed enclosure.
- A subwoofer in an optimum vented enclosure will require less amplifier power to achieve a given acoustic output (down to the enclosure's resonance frequency) than in an optimum sealed enclosure.

## VENTED-ENCLOSURE PERFORMANCE TRADE-OFFS

- Reduced output in the lowest octave (below 40Hz).
- Reduced mechanical power handling below the enclosure's resonance frequency. The use of an electronic infrasonic filter is strongly recommended to reduce the chance of overdriving the subwoofer below the enclosure's resonance frequency.
- An optimum vented enclosure will always be larger than an optimum sealed enclosure.

## VENTED-ENCLOSURE CONSTRUCTION

Vented-enclosure construction is more difficult than the construction of a sealed enclosure. The enclosure volume and port dimensions have a specific relationship with the physical and electromechanical characteristics of the subwoofer, requiring that the recommended enclosure volume and port characteristics be strictly observed. As with sealed enclosures, use medium-density fiberboard (MDF), glue and screws to construct the enclosure, and seal all joints with silicone caulk.

## RECOMMENDATION

Subwoofers in vented enclosures are recommended for enthusiasts who prefer accentuated bass response, for those who have plenty of cargo space to devote to a subwoofer enclosure and for those who will use a less powerful amplifier to drive their subwoofer. The volume and port

dimensions indicated must be followed precisely to ensure optimum performance.

## MOUNTING THE SUBWOOFER

The subwoofers should be mounted from the outside of the enclosure. Use the included foam mounting gasket to ensure a leak-free seal between the subwoofer frame and the enclosure.

## CONNECTING THE SUBWOOFER

### SETTING THE IMPEDANCE

The Stadium subwoofers both feature the Selectable Smart Impedance™ (SSI) switch. This exclusive feature lets you set the subwoofer's impedance to either 2 ohms or 4 ohms with the flip of a switch (see illustrations below). This allows you to extract the most from your subwoofer amplifier in any situation.

The SSI 2-ohm setting increases the subwoofer's output over the 4-ohm setting by up to 3dB, depending on the amplifier. Performance is identical in all other respects. If the connected amplifier is rated for 2-ohm operation and its 2-ohm power ratings are within the subwoofer's power-handling specifications, setting the SSI switch in the 2-ohm position will achieve maximum output.

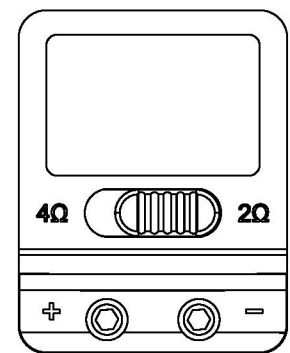

2-Ohm Setting

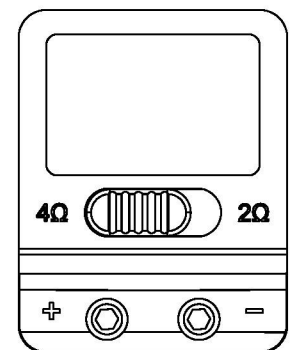

4-Ohm Setting

**IMPORTANT:** Make sure the subwoofer amplifier is turned OFF before setting the SSI switch. Do not change the switch position while the subwoofer amplifier is operating. Doing so could damage the amplifier.

### CONNECTING THE AMPLIFIER

The subwoofer connectors are compatible with bare or tinned wires. The recommended wire gauge is between 14AWG and 8AWG, depending on the length of the wire run between the amplifier and woofer. Heavier gauge wire is preferred for runs over 6' (2m).

1. Use a 2.5 mm hex driver to open the connectors
  2. Insert the wire ends into the connector openings
- NOTE:** If using untinned bare wire, be sure that no stray "+" and "-" strands touch each other. Touching strands can cause a short-circuit, which can damage your amplifier.
3. Use the hex driver to secure the wires in the connectors, as shown in the illustration to the left

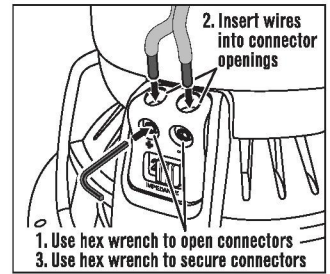

### TECHNICAL DATA

## Stadium 1024

#### THIELE-SMALL PARAMETERS

	2Ω	4Ω
VOICE-COIL DC RESISTANCE:	REVC (OHMS) . . . . . 1.80	4.06
VOICE-COIL INDUCTANCE @ 1kHz:	LEVC (MH) . . . . . 1.04	0.91
DRIVER RADIATING AREA:	SD (IN <sup>2</sup> ) . . . . . 53.69	53.69
	SD (CM <sup>2</sup> ) . . . . . 346.36	346.36
MOTOR FORCE FACTOR:	BL (T <sub>w</sub> ) . . . . . 10.54	14.98
COMPLIANCE VOLUME:	VAS (FT <sup>3</sup> ) . . . . . 0.86	0.89
	VAS (LITERS) . . . . . 24.22	25.27
SUSPENSION COMPLIANCE:	CMS (IJM/N) . . . . . 144.00	150.00
MOVING MASS, AIR LOAD:	MMS (GRAMS) . . . . . 188.72	185.47
FREE-AIR RESONANCE:	FS (Hz) . . . . . 30.56	30.18
MECHANICAL Q:	QMS . . . . . 3.11	2.17
ELECTRICAL Q:	QES . . . . . 0.57	0.61
TOTAL Q:	QTS . . . . . 0.48	0.48
MAGNETIC-GAP HEIGHT:	HAG (IN) . . . . . 0.39	0.39
	HAG (MM) . . . . . 10.00	10.00
VOICE-COIL HEIGHT:	HVC (IN) . . . . . 1.32	1.32
	HVC (MM) . . . . . 33.50	33.50
MAXIMUM EXCURSION:	XMAX (IN) . . . . . 0.47	0.47
	XMAX (MM) . . . . . 12.00	12.00

## Stadium 1224

#### THIELE-SMALL PARAMETERS

	2Ω	4Ω
VOICE-COIL DC RESISTANCE:	REVC (OHMS) . . . . . 1.82	4.07
VOICE-COIL INDUCTANCE @ 1kHz:	LEVC (MH) . . . . . 1.03	0.94
DRIVER RADIATING AREA:	SD (IN <sup>2</sup> ) . . . . . 82.29	82.29
	SD (CM <sup>2</sup> ) . . . . . 530.93	530.93
MOTOR FORCE FACTOR:	BL (T <sub>w</sub> ) . . . . . 11.70	16.99
COMPLIANCE VOLUME:	VAS (FT <sup>3</sup> ) . . . . . 1.93	1.86
	VAS (LITERS) . . . . . 54.65	52.59
SUSPENSION COMPLIANCE:	CMS (IJM/N) . . . . . 138.00	133.00
MOVING MASS, AIR LOAD:	MMS (GRAMS) . . . . . 220.58	225.64
FREE-AIR RESONANCE:	FS (Hz) . . . . . 28.84	29.07
MECHANICAL Q:	QMS . . . . . 4.29	2.56
ELECTRICAL Q:	QES . . . . . 0.53	0.58
TOTAL Q:	QTS . . . . . 0.47	0.47
MAGNETIC-GAP HEIGHT:	HAG (IN) . . . . . 0.39	0.39
	HAG (MM) . . . . . 10.00	10.00
VOICE-COIL HEIGHT:	HVC (IN) . . . . . 1.32	1.32
	HVC (MM) . . . . . 33.50	33.50
MAXIMUM EXCURSION:	XMAX (IN) . . . . . 0.47	0.47
	XMAX (MM) . . . . . 12.00	12.00

### SEALED-BOX VOLUME (INCLUDES DRIVER DISPLACEMENT)

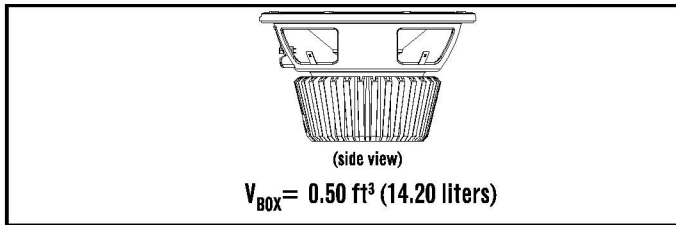

### SEALED-BOX VOLUME (INCLUDES DRIVER DISPLACEMENT)

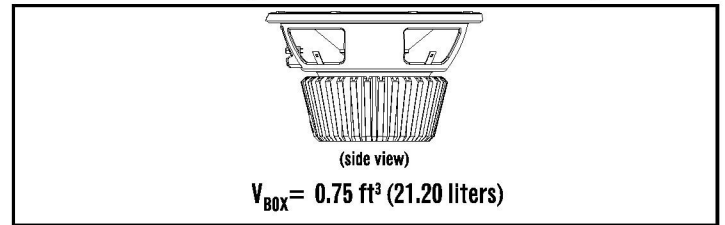

### VENTED-BOX VOLUME (INCLUDES DRIVER/PORT DISPLACEMENTS)

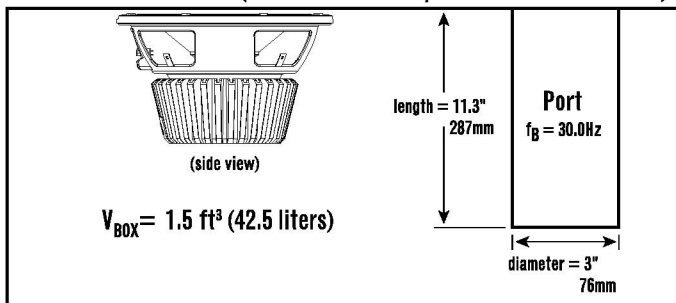

### VENTED-BOX VOLUME (INCLUDES DRIVER/PORT DISPLACEMENTS)

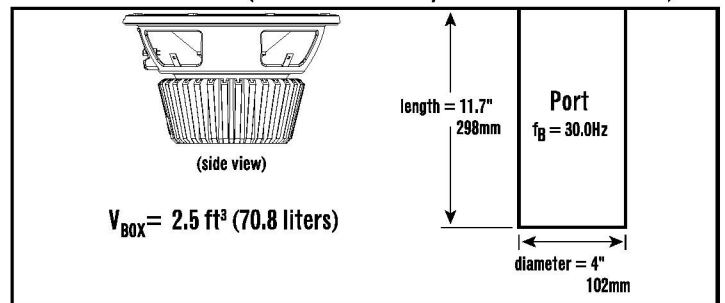

### SPECIFICATIONS

**DIAMETER:** 10" (254MM)  
**SENSITIVITY (2.83V @ 1m):** 91dB  
**POWER HANDLING:** 450Wrms (1350W PEAK)  
**FREQUENCY RESPONSE:** 30Hz ~ 175Hz  
**NOMINAL IMPEDANCE:** 2 OR 4 OHMS  
**VOICE-COIL DIAMETER:** 2 1/2" (63MM)  
**DIMENSIONS:**

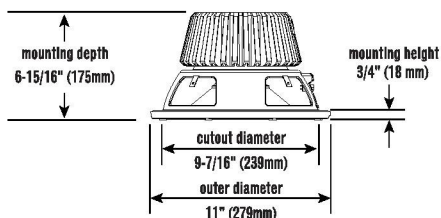

### SPECIFICATIONS

**DIAMETER:** 12" (305MM)  
**SENSITIVITY (2.83V @ 1m):** 92dB  
**POWER HANDLING:** 500Wrms (1500W PEAK)  
**FREQUENCY RESPONSE:** 25Hz ~ 175Hz  
**NOMINAL IMPEDANCE:** 2 OR 4 OHMS  
**VOICE-COIL DIAMETER:** 2 1/2" (63MM)  
**DIMENSIONS:**

