

2344A Bi-Radial® Horn

Professional Series

Key Features:

- ▶ Bi-Radial® Constant-Coverage horn design
- ▶ 100° x 100° dispersion from 1 kHz to 12.5 kHz
- ▶ Full horn loading to 800 Hz
- ▶ Compact size and lightweight construction
- ▶ 25 mm (1 in) throat entry

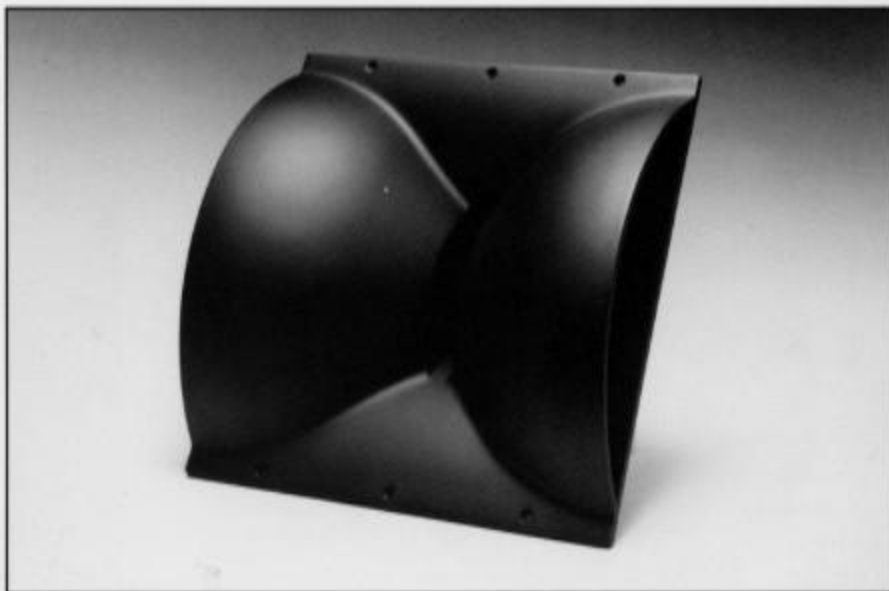

Since its introduction in the 4430 and 4435 Bi-Radial® monitor systems, the 2344A Horn¹ has gained acceptance as a specialized device in applications requiring wide coverage in both horizontal and vertical planes. Horizontal coverage is maintained to 16 kHz, while vertical coverage is maintained to 12.5 kHz. The rapid flare rate of the horn results in relatively low distortion at high acoustical power output, making the horn ideal for music applications.

Computer aided design techniques based on a polynomial power series equation were used to derive the horn contours, resulting in smooth response and even coverage. The design avoids the performance compromises inherent in abrupt flare transitions or straight sidewalls. The maintenance of uniform coverage angles over the frequency range from 1 kHz to 12.5 kHz indicates that the horn can be electrically equalized to produce flat power response over that frequency band.

To ensure strength, light weight, and freedom from resonances, the horn is constructed of molded structural foam. The 2344A horn will accept any JBL 25 mm (1 in) exit high frequency compression driver with bolt-on mounting flange.

Specifications:

HORIZONTAL COVERAGE:	
Angle (- 6 dB):	100° (+ 5, - 15)
Average Range:	1 kHz - 16 kHz
VERTICAL COVERAGE:	
Angle (- 6 dB):	100° (+ 5, - 30)
Average Range:	1 kHz - 12.5 kHz
Directivity Index (DI):	7.8 dB (+ .9, - 1.1)
Directivity Factor (Q):	6 (+ 1.4, - 1.3)
Average Range:	1 kHz - 12.5 kHz
Usable Low Frequency Limit:	800 Hz
Minimum Recommended Crossover Frequency:	800 Hz
Axial Pressure Sensitivity ¹ :	107 dB SPL, 1 W @ 1 m
Construction:	Molded structural foam (nominal 6 mm (¼ in) wall thickness)
OVERALL DIMENSIONS:	
Mouth Height:	320 mm (12.6 in)
Mouth Width:	320 mm (12.6 in)
Length:	165 mm (6.5 in)
Baffle Cutout Required:	254 mm (10 in) square cutout
Net Weight:	2.41 kg (5.3 lbs)

¹ Measured on-axis in the far field with 1 watt input (4.0 volts rms, 16 ohms) and referred to 1 meter distance using inverse square law. Listed sound pressures (SPL, re 20µPa) represent an average from 1 kHz to 4 kHz using the 2426 driver.

JBL continually engages in research related to product improvement. New materials, production methods, and design refinements are introduced into existing products without notice as a routine expression of that philosophy. For this reason, any current JBL product may differ in some respect from its published description, but will always equal or exceed the original design specifications unless otherwise stated.

► 2344A Bi-Radial® Horn

Frontal Isobar Contours

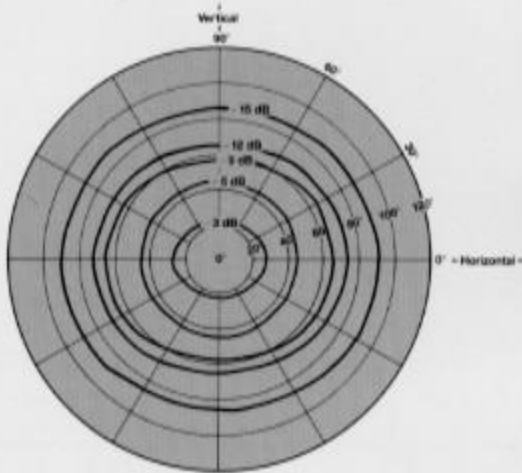

1 kHz octave bandwidth constant sound pressure contours of -3 to -12 dB in steps of 3 dB. The contours are plotted on polar grid lines with on axis being the center of the plot. The data was gathered by taking octave polar plots at oblique angles from 0° (horizontal) to 90° (vertical) in steps of 30°

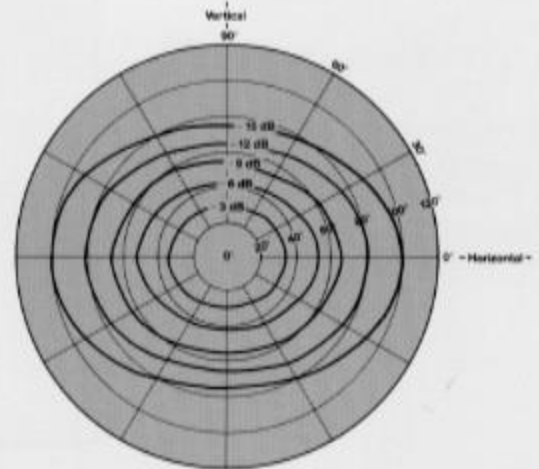

2 kHz octave bandwidth sound pressure contours. Same conditions as 1 kHz contours.

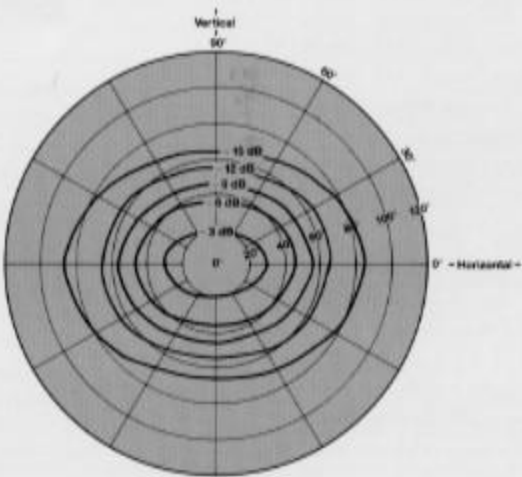

4 kHz octave bandwidth constant sound pressure contours. Same conditions as 1 kHz contours.

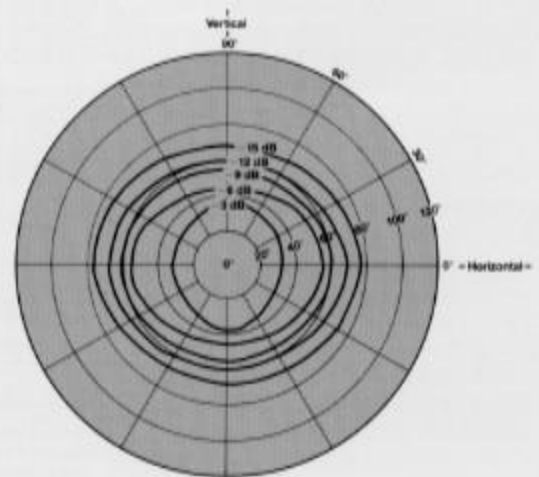

8 kHz octave bandwidth constant sound pressure contours. Same conditions as 1 kHz contours.

Beamwidth (-6 dB) versus Frequency

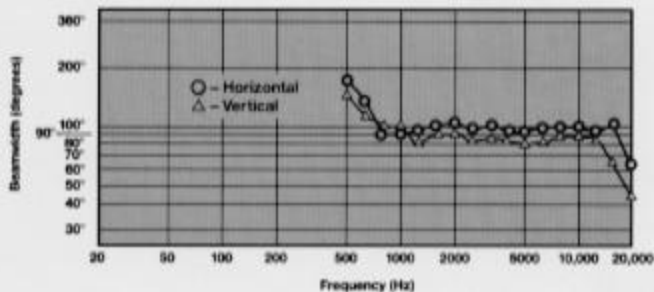

Directivity vs. Frequency

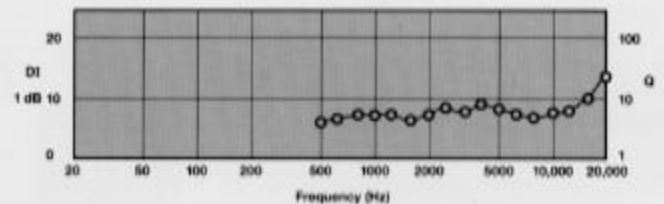

Harmonic distortion.

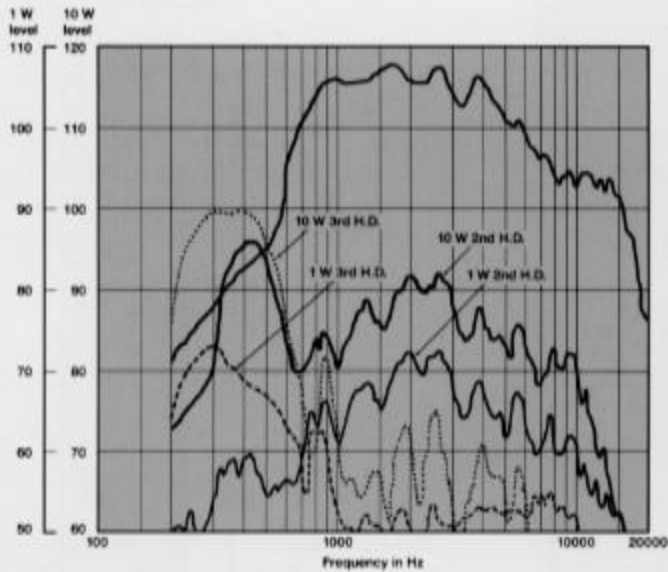

Second and third harmonic distortion curves of the 2344A with 1 watt (2.24 V rms) and 10 watts (7.1 V rms) applied to the JBL Model 2426H compression driver (impedance minimum 5 ohms). Measured on axis at a distance of 1 meter in a reflection free environment.

Frequency response and impedance.

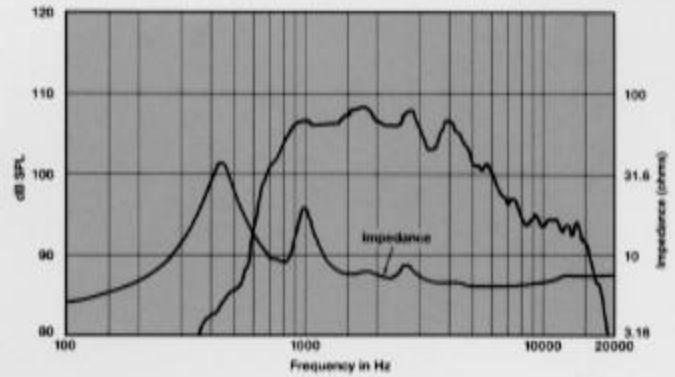

Frequency response of the 2344A, measured on axis at a distance of 1 meter with 1 watt (2.24 V rms) applied to a JBL Model 2426H compression driver (impedance minimum 5 ohms), in a reflection free environment, with impedance vs. frequency curve.

Horizontal off-axis response.

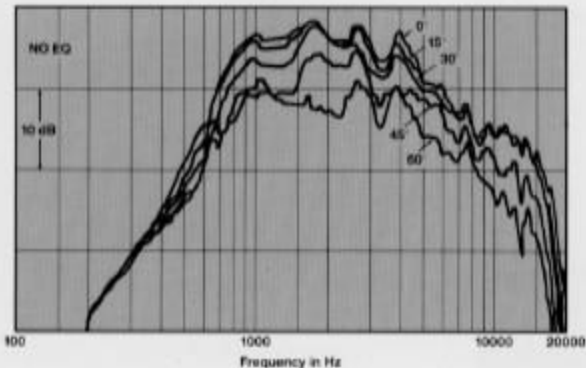
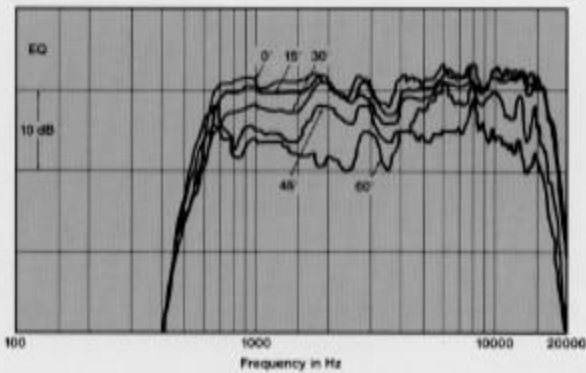

Horizontal off-axis response taken at 15° intervals out to 60° off axis. Both normalized (equalized flat on axis) and unequalized response are shown.

Vertical off-axis response.

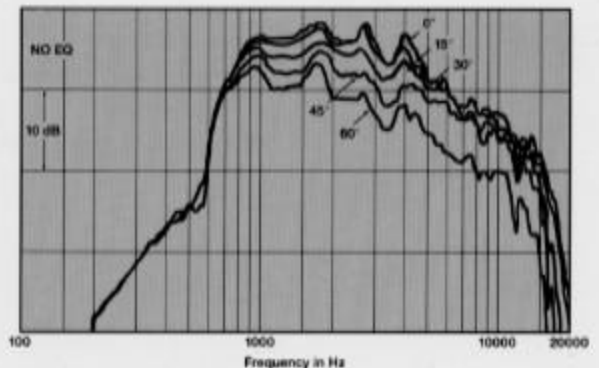
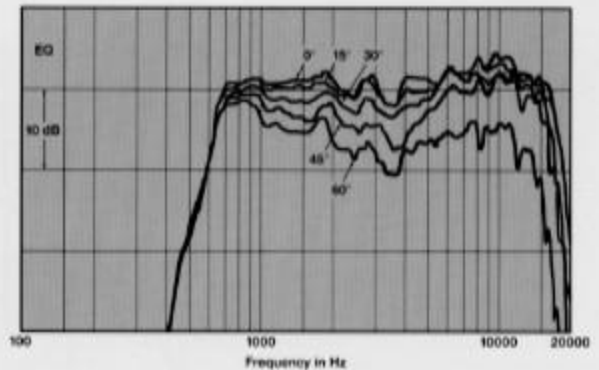

Vertical off-axis response taken at 15° intervals out to 60° off axis. Both normalized (equalized flat on axis) and unequalized response are shown.

► 2344A Bi-Radial® Horn

Dimensions are in millimeters.
Dimensions in () are in inches.

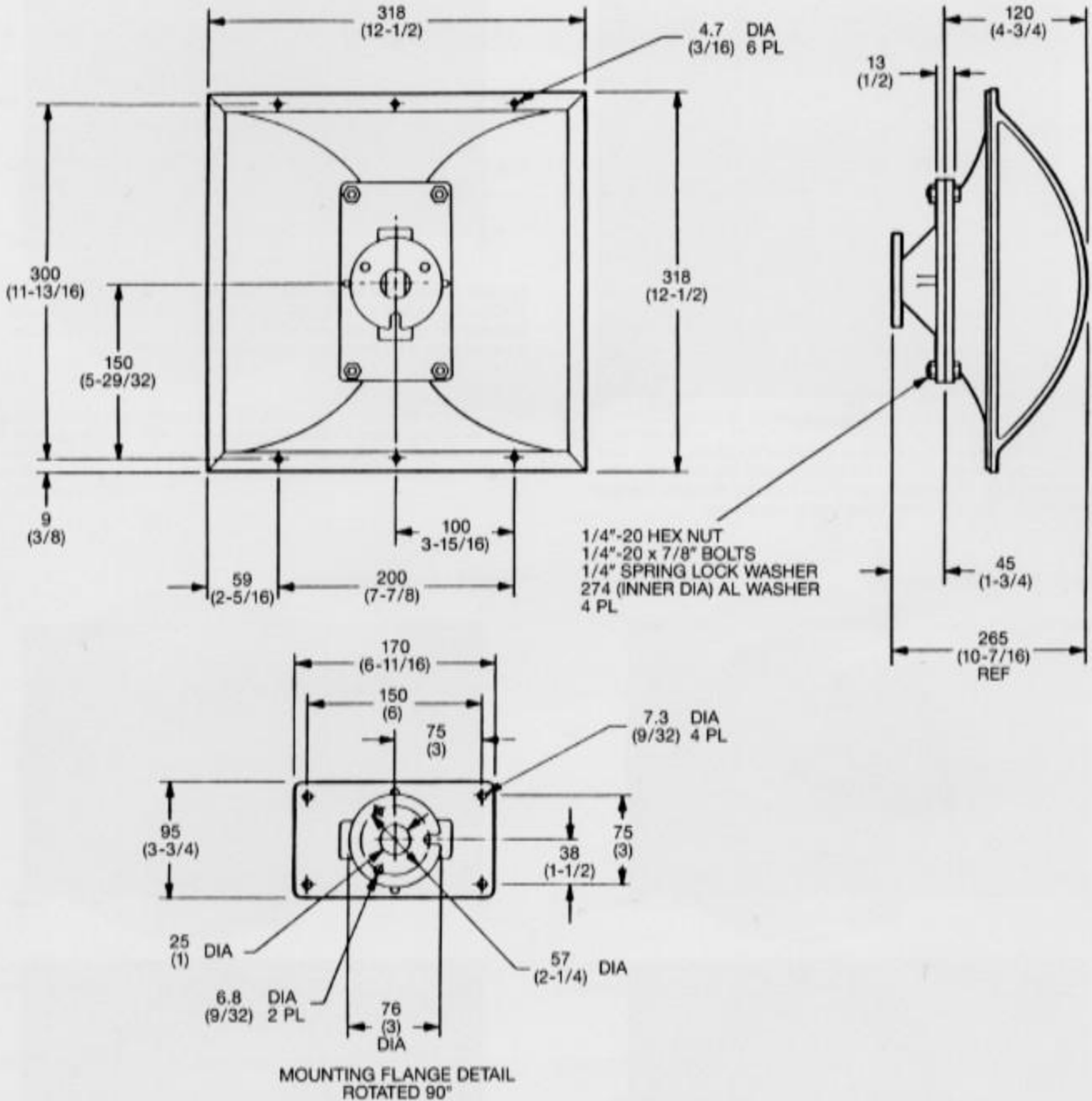

JBL Professional
8500 Balboa Boulevard, P.O. Box 2200
Northridge, California 91329 U.S.A.

■ A Harman International Company

SS 2344A
CRP 6M
10/96