



2502

Wall Mount Bracket

The 2502 Wall Mount Bracket was designed to provide a cost effective means of safely securing any of the JBL 8300 Series Surround speakers to a wall surface. It is manufactured of rugged 10 gauge steel and finished in matte black. Multiple cabinet screw positions allow for up to a 15 degree down tilt or flush mounting to a wall surface, for optimal speaker aiming with minimal visual interference. Kit includes 3/8" x 3" lag bolts and flat/lock washers. Packed one bracket per carton.

NOTE: Always be sure that the mounting surface is structurally capable of supporting the weight of the loudspeaker.

CAUTION: Installing this bracket should only be done by qualified persons.

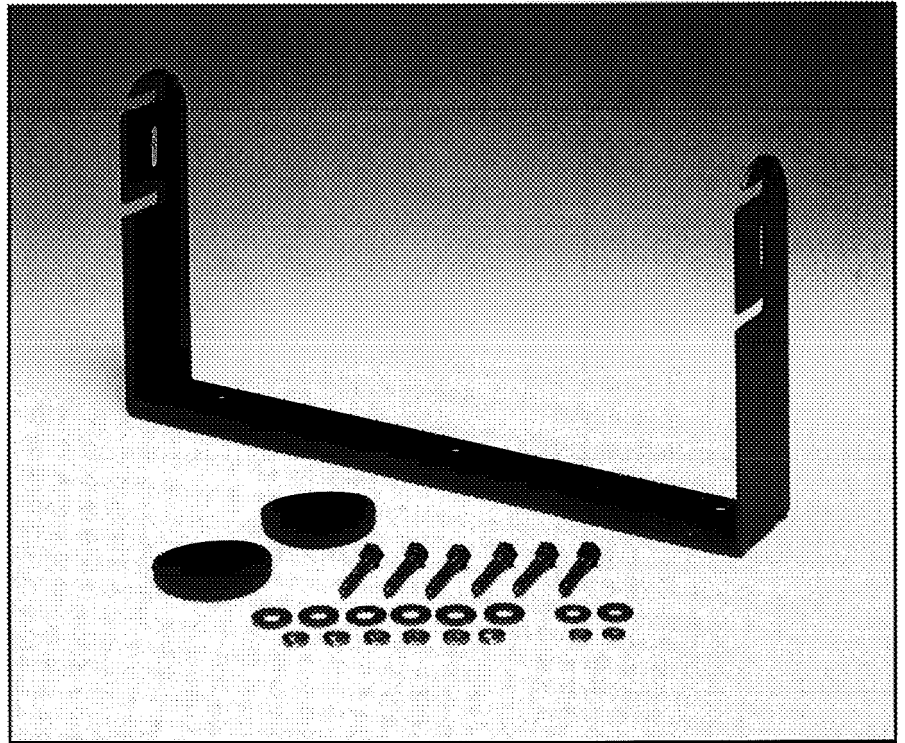

▶ 2502 Wall Mount Bracket

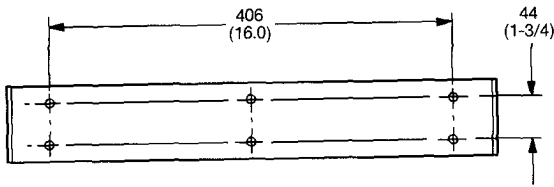

MOUNTING HOLE DIMENSIONS

Install With Slots Facing Upward

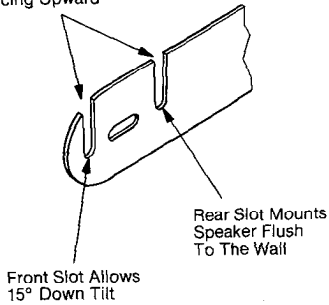

SPEAKER MOUNTING INSTRUCTIONS

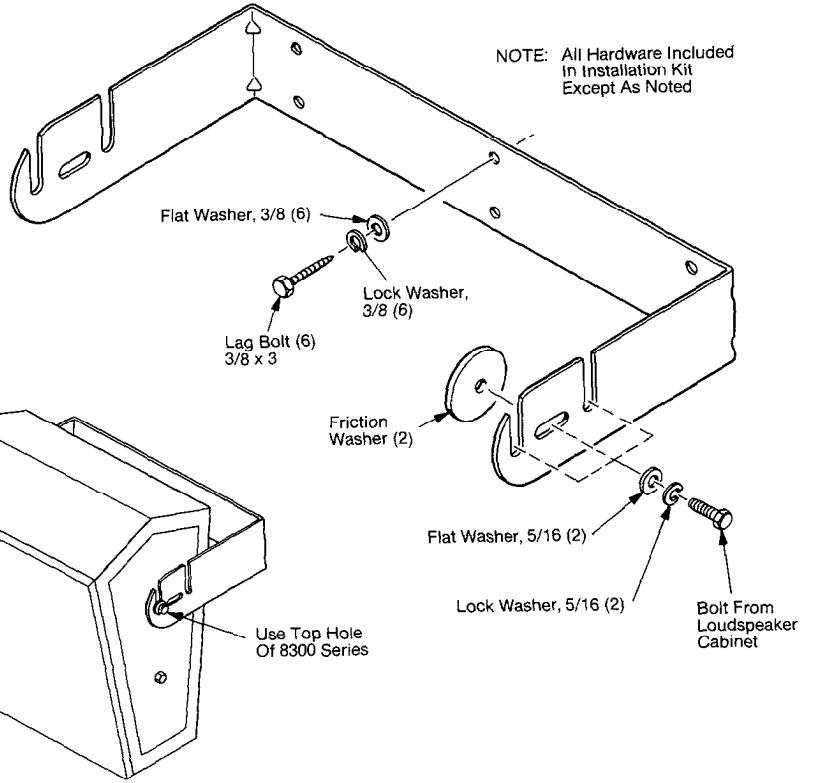

**8300 SERIES
(8340 Shown)**

CAUTION:
Installing this bracket should only be done by qualified persons.

JBL continually engages in research related to product improvement. New materials production methods and design refinements are introduced into existing products without notice as a routine expression of that philosophy. For this reason, any current JBL product may differ in some respect from its published description but will always equal or exceed the original design specifications unless otherwise stated.



JBL Professional
8500 Balboa Boulevard, P.O. Box 2200
Northridge, California 91329 USA

H A Harman International Company

SS2502
CRP 5M
9/95

2502 Wall Mount Bracket

Note: Dimensions in Inches

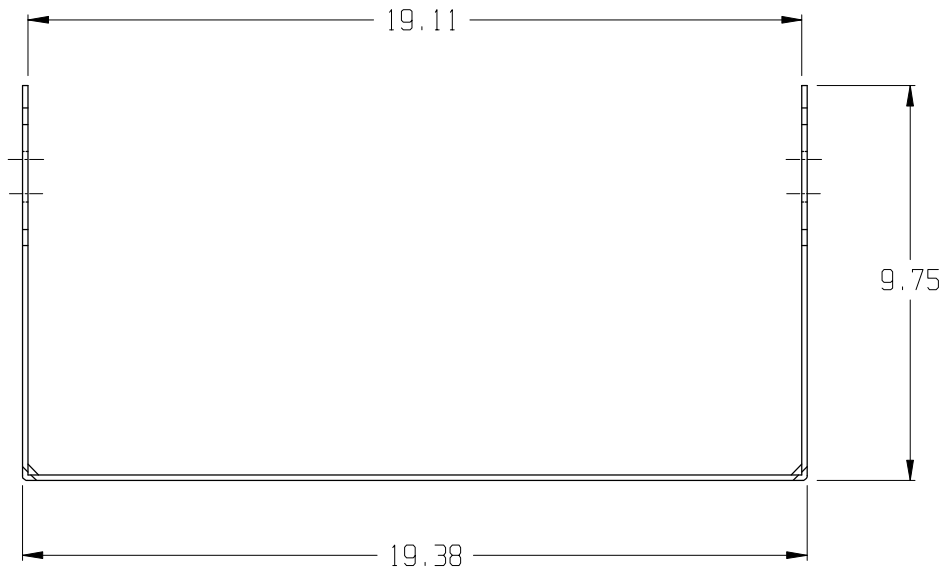

Top View

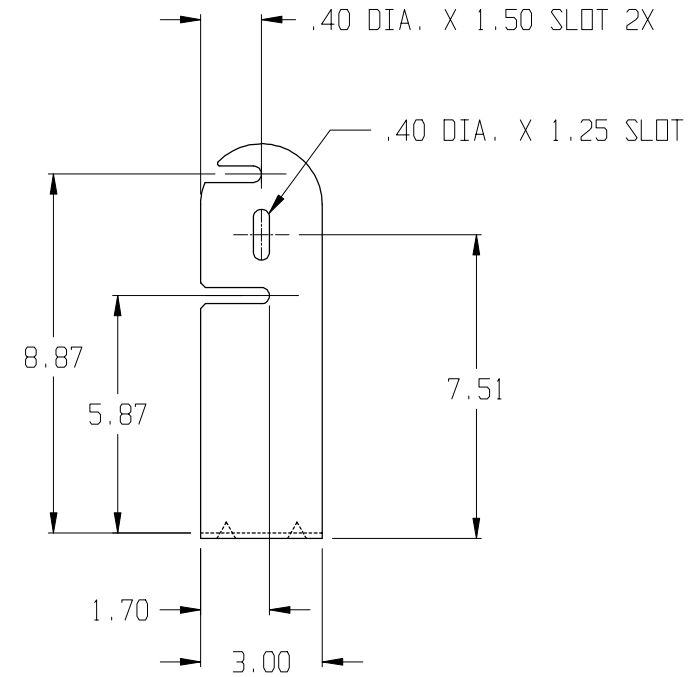

Side View

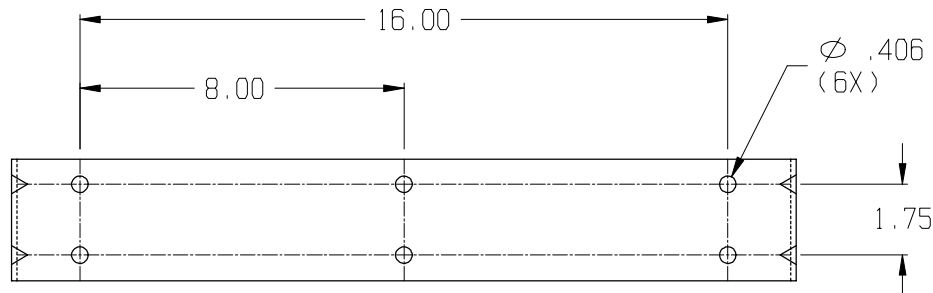

Front View

Hardware Kit:

- 6 pcs. 3/8" x 2" Hex lag bolt
- 2 pcs. 3/8" x 3" x 1/4" Gasket
- 6 pcs. 3/8" Flat washer
- 2 pcs. 5/16" Star lock washer
- 6 pcs. 3/8" Split lock washer
- 2 pcs. 5/16" Flat washer