

THESE DRAWINGS AND SPECIFICATIONS ARE THE PROPERTY OF JBL INCORPORATED. THEY ARE ISSUED IN STRICT CONFIDENCE AND SHALL NOT BE REPRODUCED, COPIED, OR USED AS THE BASIS FOR MANUFACTURE OR SALE OF APPARATUS WITHOUT WRITTEN PERMISSION.

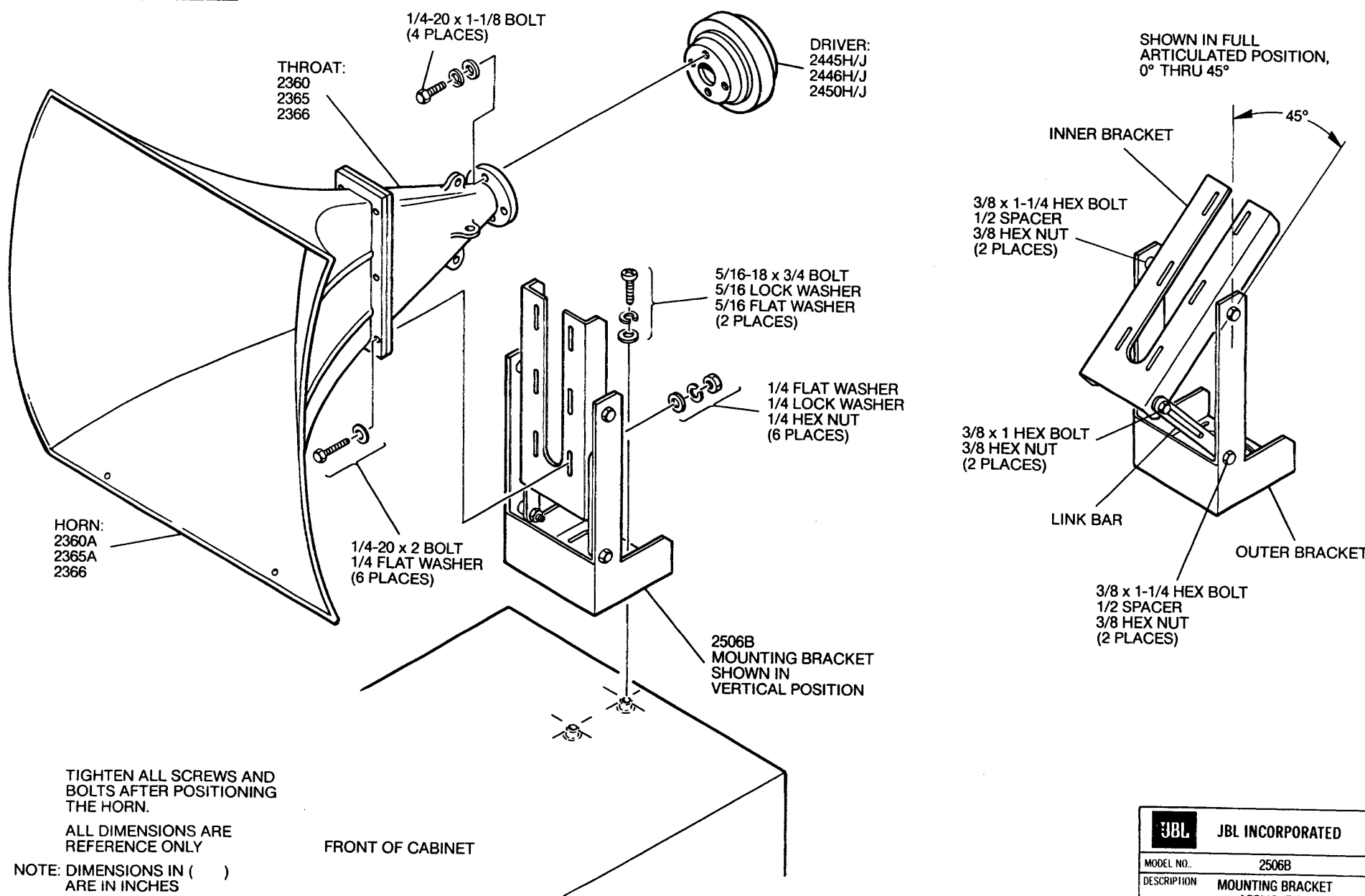

TIGHTEN ALL SCREWS AND BOLTS AFTER POSITIONING THE HORN.

ALL DIMENSIONS ARE REFERENCE ONLY

NOTE: DIMENSIONS IN ( ) ARE IN INCHES

<b>JBL</b>	<b>JBL INCORPORATED</b>
MODEL NO.	2506B
DESCRIPTION	MOUNTING BRACKET APPLICATION
DIMENSIONS IN mm UNLESS SPECIFIED OTHERWISE	
DRAWING NOT SCALED	