

Array Series

Key Features:

- ▶ Wide Coverage Angle Design
90° Horizontal Horn Pattern for Non-arrayed Applications
- ▶ High Technology Transducers
355 mm (14 in) Ultra-low Distortion Neodymium Woofer with Unique Gap Topology
38 mm (1½ in) exit, 100 mm (4 in) diaphragm Neodymium Compression Driver
- ▶ Secure Array Flying Ergonomics - S.A.F.E.[™]
Internal Steel Braces accept Optional Truss Module and Hardware
- ▶ Integrally Designed with JBL Array Series Controllers
Choose Analog, or Digital Controller for optimum system performance
- ▶ Versatile
Concert and Theater Reinforcement, AN Presentation, High Power Installations

Array Series Systems

JBL's commitment of providing audio professionals the best tools for their work continues with the Array Series. JBL Array Series systems provide the ultimate performance for touring and fixed installations. The high power, compact 4892-90 provides smooth, wide predictable coverage and response from a single box. It combines ease of transport with the flexibility to fly or install quickly and safely. Integration of advanced design high power transducers, a new generation of horns, and advanced control electronics provides clearly superior performance. Reliability is designed in without having to rely on intrusive signal processing.

Components

Array Series builds upon a solid foundation: more than 40 years of JBL transducer expertise and engineering. The 355 mm (14 in) low frequency transducer represents JBL's commitment to research. New technology includes a unique deep copper-sleeved gap low-distortion motor structure topology, coupled to Vented Gap Cooling (VGC[™])i to produce



Specifications:

Frequency Response (± 3 dB):	50 Hz 18 kHz
Sensitivity:	98 dB (1 W, 1 m)
Recommended Amplifier Power ¹ :	
High Frequency:	300 W at 8 ohms
Low Frequency:	600 W at 8 ohms
Nominal Coverage:	90° horizontal, 40° vertical
LOW FREQUENCY TRANSDUCERS:	
Nominal Diameter:	355 mm (14 in)
Nominal Impedance:	8 ohms
Power Rating:	600 watts AES, 50 Hz to 500 Hz, 2400 W peak
Voice Coil:	100 mm (4 in) edgewound aluminum ribbon
Features:	Ultra linear, neodymium magnet motor structure Vented Gap Cooling
HIGH FREQUENCY TRANSDUCER:	
Throat Diameter:	38 mm (1½ in) exit
Nominal Impedance:	8 ohms
Power Rating:	75 watts AES, 1 kHz to 10 kHz, 300 W peak
Diaphragm:	100 mm (4 in) pure titanium
Voice Coil:	100 mm (4 in) edgewound aluminum ribbon
Features:	Neodymium magnet motor structure
HIGH FREQUENCY HORN:	
Type:	Optimized Aperture [™] Flat-Front Bi-Radial*
Material:	Fiberglass reinforced plastic
Coverage:	90° horizontal, 40° vertical
ENCLOSURE:	
Type:	Vented, 45° included angle trapezoid
Material:	19 mm (¾ in), 13 ply hardwood
Flying System:	S.A.F.E. - JBL proprietary, modular, certified
Finish:	Black textured paint
Grille:	16 ga. perforated steel, foam backed
Connectors:	Parallel 8 pin Neutrik pins 1 \pm LF1, pins 3 \pm HF
Dimensions:	1066 x 394 x 362 mm H x W x D (42 x 15½ x 14¼ in)
Net Weight:	47.3 kg (104 lb)

¹Half Space measurement.

²Recommended Power Amplifier ratings are a guide for amplifier selection considering normal program material and line voltage available to amplifiers, although lower power amplifiers may be utilized. The 4894 system is capable of significantly greater peak power input.

▶ 4892-90 High Power Two-Way Loudspeaker System

the accurate reproduction at high power levels with minimal power compression. A new 38 mm (1½ in) exit neodymium high frequency compression driver with Coherent Wave™ phasing plug and 100 mm (4 in) titanium diaphragm delivers low distortion response to beyond 20 kHz. A 90° Optimized Aperture™ Flat-Front Bi-Radial® horn2 provides accurate pattern control over its entire bandwidth.

S.A.F.E.™ Secure Array Flying Ergonomics

Important for both portable and installation applications is the ability to rig a cluster quickly, but with absolute safety. The 4892-90 has four internal steel braces that are ready to accept optional bolt-on truss modules. An array to provide desired coverage can be quickly assembled using a few basic fittings. Ultimate break strength of this method exceeds 2700 kg (6000 lb). A complete line of hardware is available for many applications including flying subwoofers in an array.

Active Control

The ASC24 provides cost effective analog signal processing with simple setup. The DSC280 offers additional precision, flexibility, and user convenience available only in the digital domain. Both provide superior high level sound quality.

Enclosure

Extremely rigid 19 mm (¾ in) 13 ply hardwood, a textured black paint finish, and a perforated 16 ga. steel grille form a durable package.

Applications

The 4892-90 is ideal for applications requiring high fidelity, high level music reproduction, or high intelligibility speech reinforcement. For applications requiring very low frequency reinforcement the 4893 subwoofer's dimensions match the 4892-90 allowing convenient integration.

³U.S. Patent #4,308,932

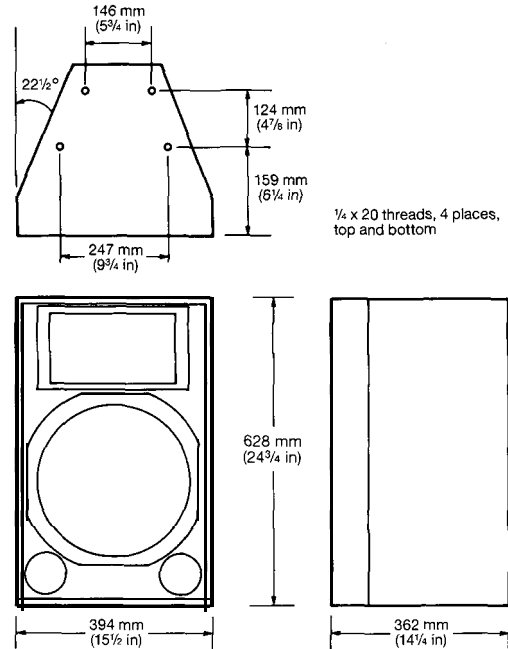

Optional S.A.F.E. Fittings

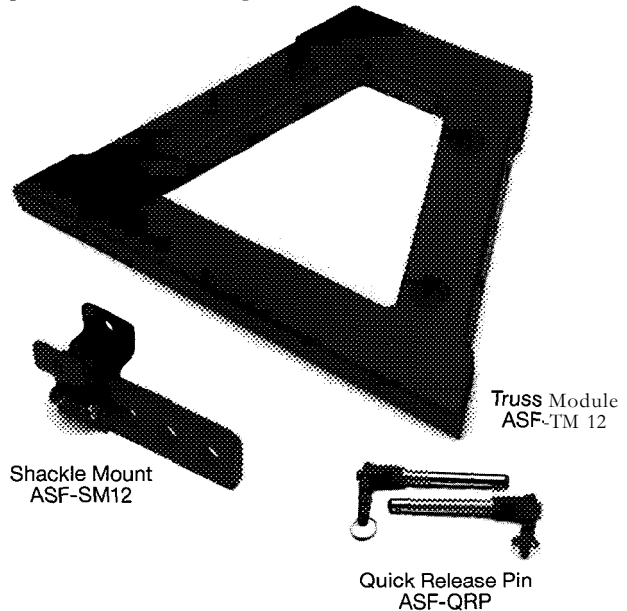

OPTIONAL S.A.F.E. FLYING HARDWARE:	
Truss Module:	Cabinet flying truss
Shackle Mount:	Attaches truss module to create a lifting point
Yoke Module:	Connects to Truss module and Clamp to allow Vertical Tilt
Quick Release Pin:	Locks S.A.F.E. components
Locking Steel Carabiner:	Used with shackle mount
Net Weight loudspeaker with Truss Modules installed:	34 kg (75 lb)

JBL continually engages in research related to product improvement. New materials, production methods, and design refinements are introduced into existing products without notice as a routine expression of that philosophy. For this reason, any current JBL product may differ in some respect from its published description but will always equal or exceed the original design specifications unless otherwise stated.



JBL Professional
8500 Balboa Boulevard, PO. Box 2200
Northridge, California 91329 U.S.A.
H A Harman International Company

SS 4892-90
CRP 5M
10/96