

4943 SYSTEM



FEATURES:

Optimum matching of amplifier power and signal processing to loudspeaker systems

Electronic equipment mounted and wired for immediate use

Standardized equipment interconnect cables

Certified hanging and rigging hardware

Systems fully tested before shipment

Stereo (two channel) capability

Optional four-way (4943T) configuration

The JBL 4943 is a complete two-channel, three-way loudspeaker and amplification system ready to operate with the addition of source and mixing equipment. The 4943 consists of loudspeaker systems, power amplifiers, electronic crossover and loudspeaker signal processing equipment, rack cabinetry and loudspeaker system connecting cables.

Optimum matching of amplifier power and signal processing results from JBL's intimate knowledge of the performance capabilities and limitations of JBL transducers. This assures the highest possible levels of system performance and long-term reliability.

4943 systems are pre-wired, tested and ready for immediate use. Loudspeaker systems are equipped

JBL

**UREI
ELECTRONIC
PRODUCTS**

with certified hanging hardware for ease of installation. An accessory electronics road case and loudspeaker dollies are available for touring applications.

ARCHITECTURAL SPECIFICATIONS:

The two-channel loudspeaker and amplification system shall be manufactured by a single source and be factory assembled, tested and delivered as a complete system. The system shall conform to the following specifications:

4943
Total amplifier power available into nominal loudspeaker load impedances: 3,900 watts. Amplitude response: ± 3 dB, 25 Hz to 16 kHz. Maximum program SPL: 140 dB at 1 meter (unweighted).

The loudspeaker and amplification system shall be comprised of the following sub-system components [insert individual architectural specifications for each model listed]: 4-JBL model 4845 very low frequency loudspeaker systems; 4-JBL model 4870 two-way loudspeaker systems; 4-JBL model 3850 loudspeaker cables; 4-JBL model 3805 loudspeaker cables; 1-JBL model 9943 electronics rack, including 1-JBL 6260 amplifier (HF); 3-JBL 6290 amplifiers (2-LF, 1-VLF); and, 2-JBL 5234A dual-channel electronic crossovers with 30 Hz high-pass filters, 80 Hz and 800 Hz crossover points and power response compensating equalization.

The two-channel three-way loudspeaker and amplification system shall be the JBL Concert Series model 4943.

4943T
Total amplifier power available into nominal loudspeaker load impedances: 3,950 watts. Amplitude response: ± 3 dB, 25 Hz to 17.5 kHz. Maximum program SPL: 140 dB at 1 meter (unweighted).

The loudspeaker and amplification system shall be comprised of the following sub-system components [insert individual architectural specifications for each model listed]: 4-JBL model 4845 very low frequency loudspeaker systems; 4-JBL model 4871 three-way loudspeaker systems; 4-JBL model 3850 loudspeaker cables; 4-JBL Model 3805 loudspeaker cables; 1-JBL model 9943T electronics rack, including 1-JBL 6215 amplifier (VHF); 1-JBL 6260 amplifier (HF); 3-JBL 6290 amplifiers (2-LF, 1-VLF); and, 3-JBL 5234A dual-channel electronic crossovers with 30 Hz high-pass filters, 80 Hz, 800 Hz and 7 kHz crossover points and HF power response compensating equalization.

The two-channel four-way loudspeaker and amplification system shall be the JBL Concert Series model 4943T.

SPECIFICATIONS:

- Components:
- 4-JBL 4870 loudspeaker systems
 - 4-JBL 4845 loudspeaker systems
 - 4-JBL 3850 50 foot loudspeaker cables
 - 4-JBL 3805 5 foot loudspeaker cables
 - 1-JBL 9943 equipment rack, including:
 - 1-JBL 6260 amplifier (HF)
 - 3-JBL 6290 amplifiers (2-LF, 1-VLF)
 - 2-JBL 5234A dual-channel electronic crossovers with high-pass filtering, 80 Hz and 800 Hz crossover points and power response correction

System Specifications:

System Type:	Two-channel, three-way loudspeaker and companion amplification system.
Frequency range (-10 dB):	20 Hz to 20 kHz
Frequency response (± 3 dB):	25 Hz to 16 kHz
Amplifier power:	3,900 W (Total available power into nominal system load impedances)
Maximum SPL:	140 dB (continuous program, 1m)
Interface:	Dual female XLR input connectors with polarity reverse and ground lift switches, outputs via (4) EP-8 rear panel mounted female receptacles
Accessories:	Model 4870DL loudspeaker dolly Model 9920RC rack case and dolly
Options:	4943T four-way system—adds: 1-JBL 5234A dual-channel electronic crossover with 7 kHz crossover cards 1-JBL 6215 dual-channel power amplifier 8-JBL 2404H very high frequency transducers

9943 Function-Block Diagram (one-half)

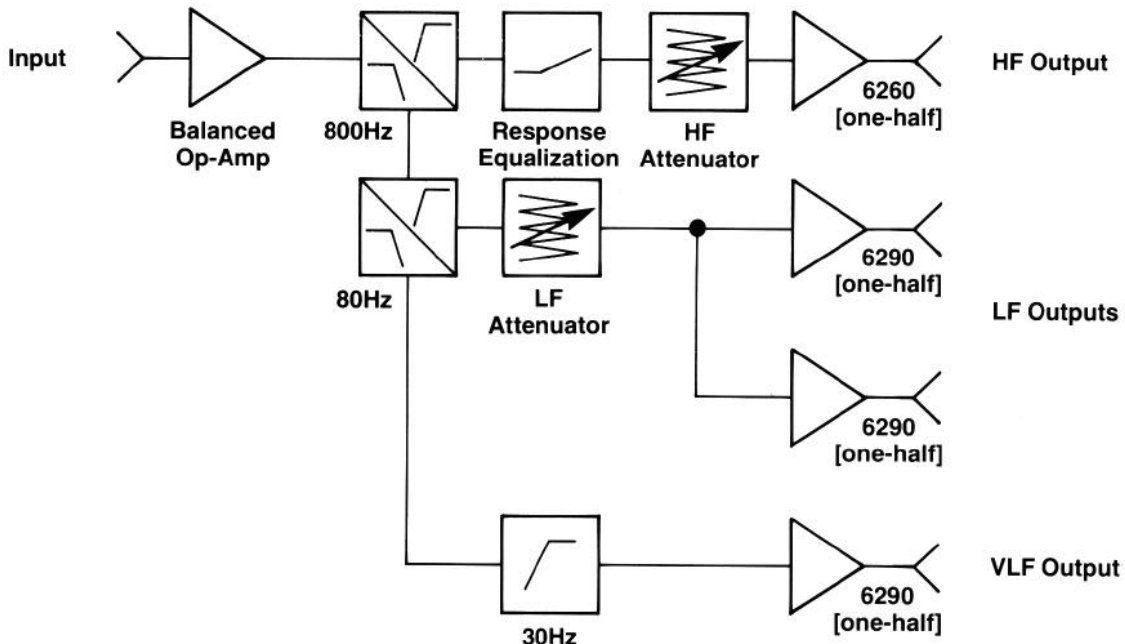

IBL/UREI continually engages in research related to product improvement. New materials, production methods, and design refinements are introduced into existing products without notice as a routine expression of that philosophy. For this reason, any current IBL/UREI product may differ in some respect from its published description but will always equal or exceed the original design specifications unless otherwise stated.

