

5671 Three-Way Screen Channel System

Application:

For critical film sound reproduction in small to medium cinemas and small production and post-production studio environments.

Key Features:

- ▶ Three-way system design for maximum output with minimum distortion
- ▶ Optimized Aperture Bi-Radial® horn and driver technology for ultra-low distortion
- ▶ Midrange pattern control for increased direct vs. reverberant ratio
- ▶ One 380 mm (15") Vented Gap Cooled (VGC™) LF transducer
- ▶ Flat-front design for easy baffle wall installation
- ▶ Fully adjustable horn bracket for aiming in any direction

Digital soundtracks on today's feature films have the potential of pushing traditional two-way speaker system designs beyond their performance limits. Requirements for wide dynamic range, high power handling, and low distortion dictate the need for a new standard of performance for today's premier cinemas.

The 5000 Series Cinema Systems feature true three-way system design, with each section optimized for its specific bandpass region. All systems feature the best of JBL transducer and horn technology to produce a system design with maximum power handling capability and acoustic power output, with extremely low distortion. The system has been designed with particular attention to power response and directivity control, allowing seamless transitions between the three acoustic sections and smooth timbral character — consistent with current industry listening standards. The 5671 provides these benefits in a system package suitable for most small to medium cinema screen channel systems, as well as for small production/post-production studio environments.

The 5671 is intended for tri-amplified use, utilizing JBL's DSC family of digital controllers. Crossover, signal alignment, and equalization can be accomplished using three channels of digital signal control, using factory pre-set tunings, for optimum performance from the 5671.



Specifications:

Frequency Range (-10 dB):	40 Hz-16 kHz
Frequency Response (±3 dB):	50 Hz-12.5 kHz
Hor. Coverage Angle (-6 dB):	80°, averaged 300 Hz to 16 kHz
Vert. Coverage Angle (-6 dB):	50°, averaged 300 Hz to 16 kHz
Directivity Factor (Q):	10.4
Directivity Index (DI):	11
Maximum peak output (1 m):	LF: 130.8 dB, MF: 140 dB, HF: 136.8 dB
Recommended Crossover Freq.	LF/MF: 320 Hz, MF/HF: 2.3 kHz
Recommended Controller:	JBL DSC family of digital controllers; tunings available in memory
Dimensions (HxWxD):	1483 mm x 774.7 mm x 736.6 mm (58.375 in x 30.5 in x 29 in.)
Net Weight:	80.2 kg (177 lbs.)
Shipping Weight:	89.4 kg (197 lbs.)
Transducers:	
Model 5641	Low Frequency: One 2226H 380 mm (15 in.) dia., 100 mm (4 in.) edgewound ribbon voice coil mounted in 4507A LF enclosure
	Nominal impedance: 8 Ohms
	Input Power Rating: 600 W, AES; one channel of 600 W into 8 ohms Recommended Amplifier
	Sensitivity: 97 dB, 1 W @ 1 m (3.3 ft.)
	Input Connectors: Barrier Strip
	Dimensions: 546 mm x 775 mm x 448 mm (21.5 in. x 30.5 in. x 17.625 in.)
	Net Weight: 28.6 kg (63 lbs.)
	Shipping Weight: 32.7 kg (72 lbs.)
Model 5671-M/HF	Mid Frequency: 2392-1 midrange horn 2490H midrange driver; 100 mm (4 in.) edgewound ribbon voice coil
	Nominal impedance: 8 Ohms
	Input Power Rating: 100 W, AES; 300 W Recommended Amplifier
	Sensitivity: 114 dB, 1 W @ 1 m (3.3 ft.)
	Net Weight: 26.3 kg (58 lbs.)
	High Frequency: 2332 horn 2451 driver; 100 mm (4 in.) edgewound ribbon voice coil
	Nominal impedance: 8 ohms
	Input Power Rating: 75 W, AES; 200 W Recommended Amplifier
	Sensitivity: 112 dB, 1 W @ 1 m (3.3 ft.)
	Net Weight: 7.26 kg (16 lbs.)
	Mounting Accessories: HF horn baffle board and mounting frame which couples MF and HF; mounts to LF enclosure for aiming/tilting

► 5671 Three-Way Screen Channel System

System Components

The 5671 consists of three sections: high frequency horn/driver, midrange horn/driver, and low frequency enclosure. The JBL 2332 Optimized Aperture Bi-Radial® horn with the JBL 2451H compression driver provides exceptionally low-distortion high frequency output due to JBL's "rapid flare" horn and driver design. The 2451H is a 1.5 inch exit driver with a neodymium magnet structure and pure titanium 100 mm diaphragm. The mid range section features JBL's 2392-1 Optimized Aperture Bi-Radial horn, coupled with the JBL 2490H 3 inch-exit compression driver, designed specifically for the critical midrange region. The low frequency section of the 5671 uses a 5 cubic foot (total net internal volume) enclosure with one JBL 2226H VGC driver.

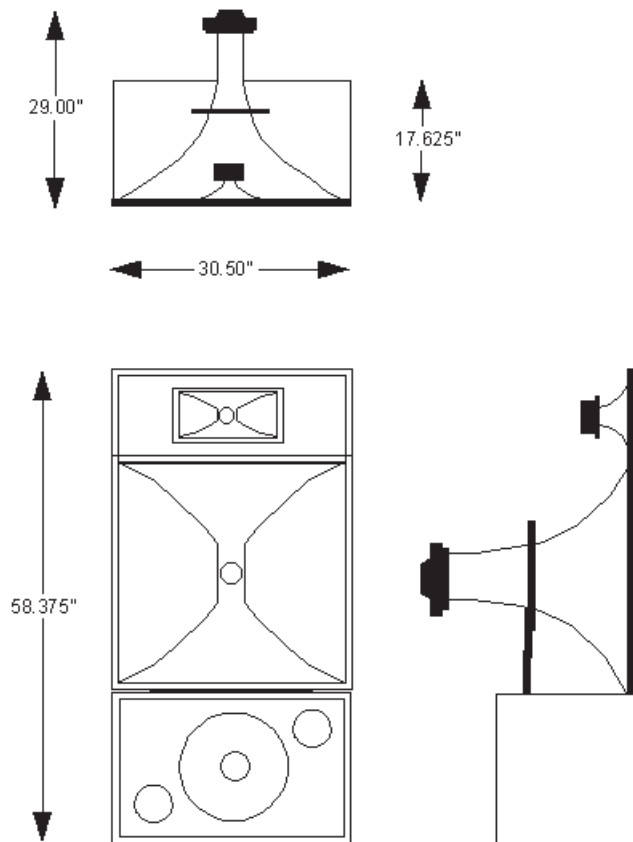

Axial Frequency Response, 1/3 octave resolution

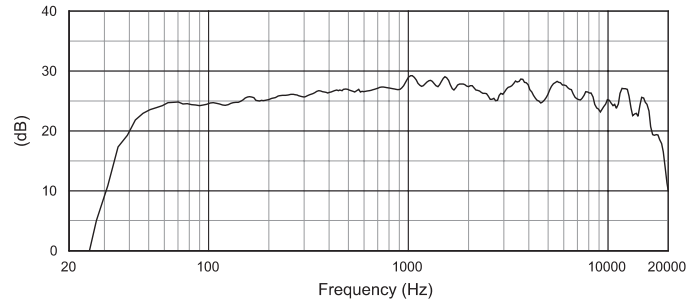

Directivity Index and Q

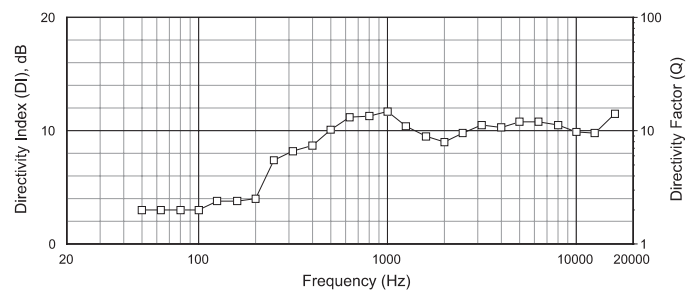

2nd and 3rd Harmonic distortion, MF and HF sections only; 10 watts at 4 meters

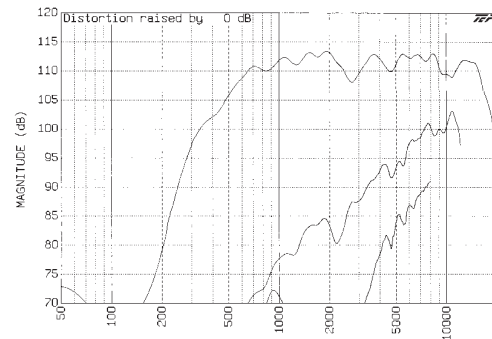

Beamwidth (-6 dB)

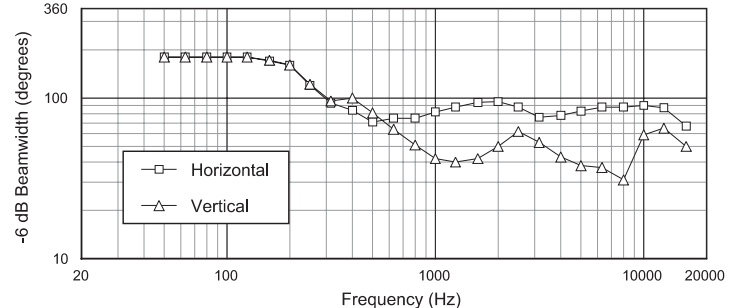

JBL Professional
8500 Balboa Boulevard, P.O. Box 2200
Northridge, California 91329 U.S.A.

■ A Harman International Company

SS 5671
CRP 15M
2/97
Rev 8/97