

**Professional Series
Technical Manual**

**Model 2901/2902
High Frequency Power Packs**



2901/2902 High Frequency Power Pack Installation Instructions

The 2901 High Frequency Power Pack consists of a 2461 compression driver coupled to a 2301 horn/lens, a 3101 frequency dividing network, and a self-adhesive nameplate. The 2902 consists of two 2402 ring radiators, a 3102 frequency dividing network, a length of black wire, and a self-adhesive nameplate. Both Power Packs include mounting hardware.

The High Frequency Power Packs are used to extend the high frequency performance of any extended range musical instrument loudspeaker having useful response up to 3 kHz. The 2901 extends response from 3 kHz to 10 kHz (± 3 dB); the 2902, from 3 kHz to 15 kHz (± 3 dB). Each can be connected to systems rated up to 300 watts at 4, 8, or 16 ohms.

The 2901 or 2902 can be installed on the same baffle panel as the existing loudspeaker, housed in a separate enclosure, or mounted on a free-standing bracket. These instructions cover the use of either of the Power Packs with a loudspeaker system other than JBL Model 4681. The installation of a 2902 in a JBL 4681 system is described in the technical manual supplied with that system.

Mounting the 2901

The combined 2461/2301 horn/lens assembly is inserted from the front through a cutout in the baffle panel and held in place by four machine screws extending through the horn flange and panel. If it is installed in the same enclosure as the existing loudspeaker, the white vinyl gasket must be in place behind the mounting flange to maintain an airtight seal.

The frequency dividing network and level control mount on the back of an enclosure panel and are held in place by four machine screws. The control adjusts high frequency level only and does not affect the crossover frequency. It is intended to project through the enclosure panel for easy access, and can be permanently identified using the self-adhesive nameplate provided.

Connecting the 2901

The frequency dividing network is fitted with two cables, each having two insulated connectors. The green and green/black wires connect to the existing loudspeaker; the yellow and yellow/black wires connect to the 2461 compression driver. Correct polarity is difficult to predict; try both possible arrangements of one set of wires to determine which results in a smoother transition.

Mounting the 2902

The two 2402 ring radiators are mounted on the back of a mounting panel and held in place by machine screws which extend through the panel from the front and thread directly into the 2402 mounting flanges. If they are installed in the same enclosure as the existing loudspeaker, the white vinyl gasket must be in place around the horn of each 2402 to maintain an airtight seal. The flat cork gasket may be used instead as a spacer to adjust horn projection through the panel.

The widest high frequency dispersion can be had by mounting the 2402s on a sub-panel affixed to the surface of the enclosure baffle: the sub-panel should provide an outward (or divergent) angle of 13° between the two units. You'll need a minimum of 217mm ($8\frac{3}{16}$ in.) in which to mount the 2402s.

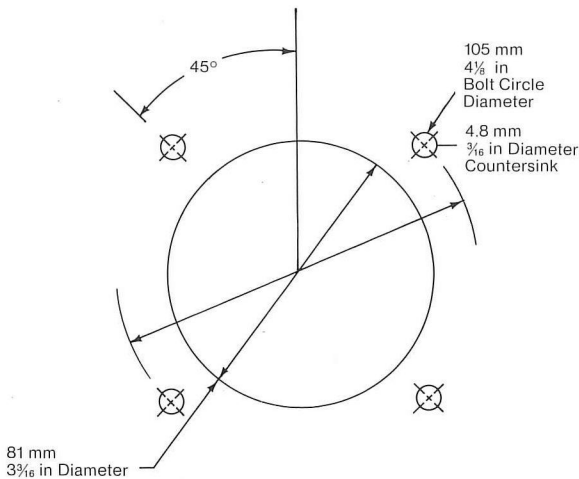

RING RADIATOR MOUNTING DIMENSIONS

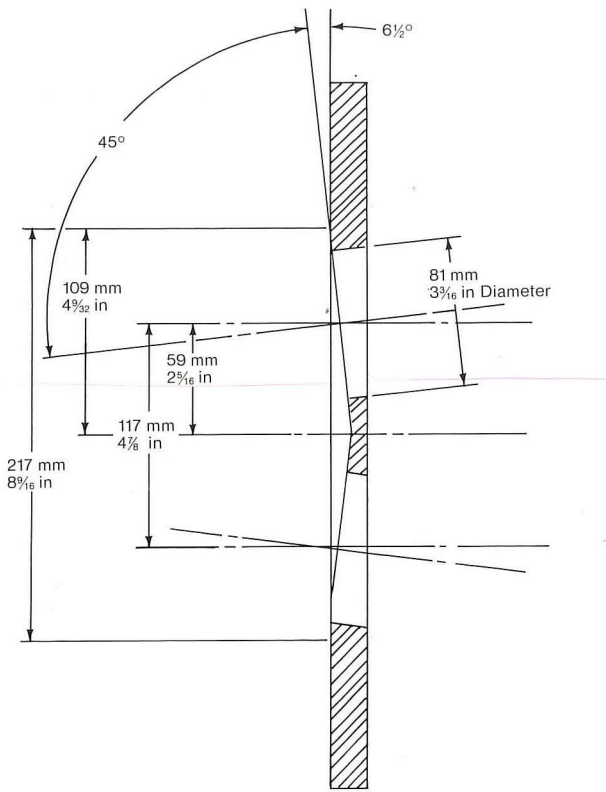

RING RADIATOR MOUNTING PANEL (Top View)

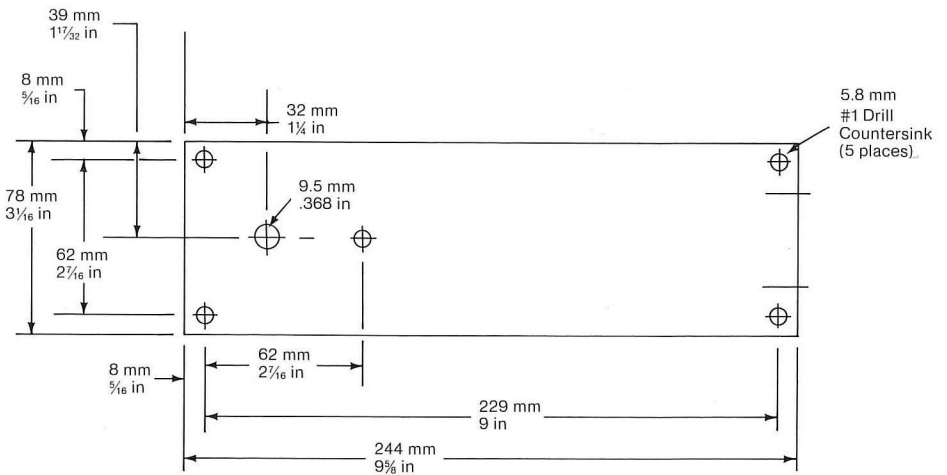

NETWORK MOUNTING PATTERN OF 3

If the 2402s are mounted on a flat baffle or bracket, the spacing between units should be as indicated in the illustration of the Mounting Panel.

The network mounts on the back of an enclosure panel and is held in place by five machine screws. The control adjusts high frequency level only; it has no effect on the crossover frequency. When mounting the network, be sure the control knob is accessible. It can be permanently identified by using the self-adhesive nameplate provided.

Connecting the 2902

The frequency dividing network is fitted with two cables, each consisting of two insulated conductors. The green and green/black wires are for the low frequency connection. If the 2402s are to be mounted on a baffle panel with a JBL musical instrument loudspeaker, connect the green wire to the red terminal of the existing loudspeaker and the green/black wire to the black terminal (these connections are in addition to the original connections to the existing loudspeaker). If the 2402s are mounted in a separate enclosure or on a bracket, or if the existing loudspeaker is not a JBL product, correct polarity is difficult to predict: try both possible arrangements of this set of wires to determine which results in a smoother transition.

The yellow and yellow/black wires are for the high frequency connection. Connect the 2402s in series with only one lead connected to each terminal. That is, connect the yellow wire to the red terminal of either 2402 and the yellow/black wire to the black terminal of the other 2402. Finally, connect the short black wire between the black terminal of the first unit and the red terminal of the second unit.

WIRING DIAGRAM FOR 2902 POWER PACK

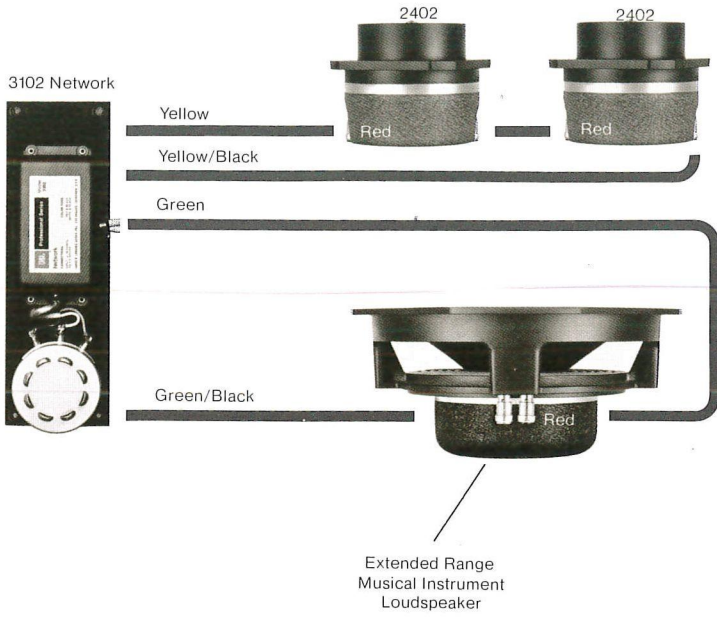



James B. Lansing Sound, Inc., 8500 Balboa Boulevard, Northridge, California 91329 U.S.A.