



A JBL INSTALLATION

Seattle's 5th Avenue Theatre

The 5th Avenue Theatre in Seattle, Washington, is a non-profit organization dedicated to the performing arts and is supported by the community. After a lengthy study of their specific needs, the management of the theatre installed a new sound reinforcement system in 1984. The acoustical consulting firm of Klepper Marshall King Associates, Ltd., of White Plains, New York, was selected for the new system design.

According to Larry King, project designer, "The objective was to provide uniform, natural sound levels with no distortion or dead spots, and to ensure excellent hearing conditions at each seat in the house." Other projects which Mr. King has worked on include the sound system in Avery Fisher Hall at Lincoln Center, New York City, the Arie Crown Theatre in Chicago, the Golden Gate Theatre in San Francisco, and the Sanger Performing Arts Theatre in New Orleans.

Mr. King further states, "It is a definite improvement over the old sound system. The 5th Avenue's sound is now comparable to any major touring theatre in the country, and the audience is sure to have a more pleasurable listening experience."

As in so many of his firm's recent designs, Mr. King chose JBL components for the central array. Six JBL model 2365 Bi-Radial™ horns are used for major house coverage. Response below 800 Hz is provided by

a vertical arc array of six JBL 2202H low frequency drivers mounted in a custom enclosure. Additional delayed loudspeakers are used for proscenium side fill, under balcony, and rear balcony coverage. Under balcony coverage is provided by twenty JBL LE8TH transducers.

System response on the main floor is maintained within 3 dB of a response window which is flat from 80 Hz to 5 kHz, sloping downward

3 dB/octave from 5 kHz to 12.5 kHz. Peak sound pressure capability in the main seating area is 105 dB SPL.

JBL Components:

- 6 2365A Bi-Radial horns
- 6 2445J Compression drivers
- 6 2202H Low frequency transducers
- 20 LE8TH Full range transducers

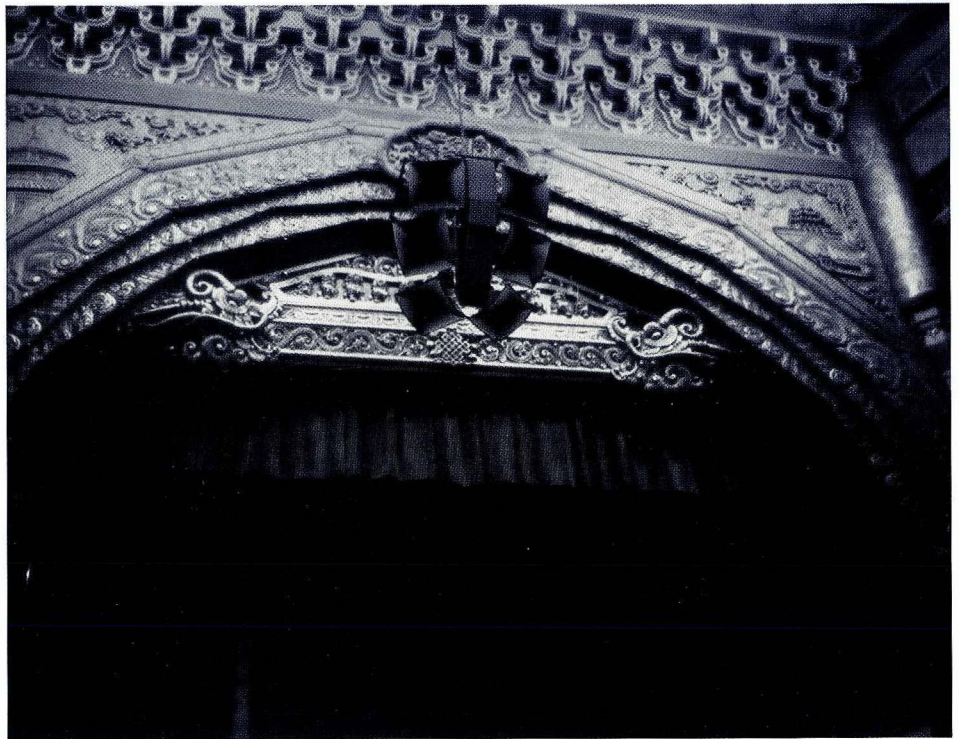

View of Central Array

JBL

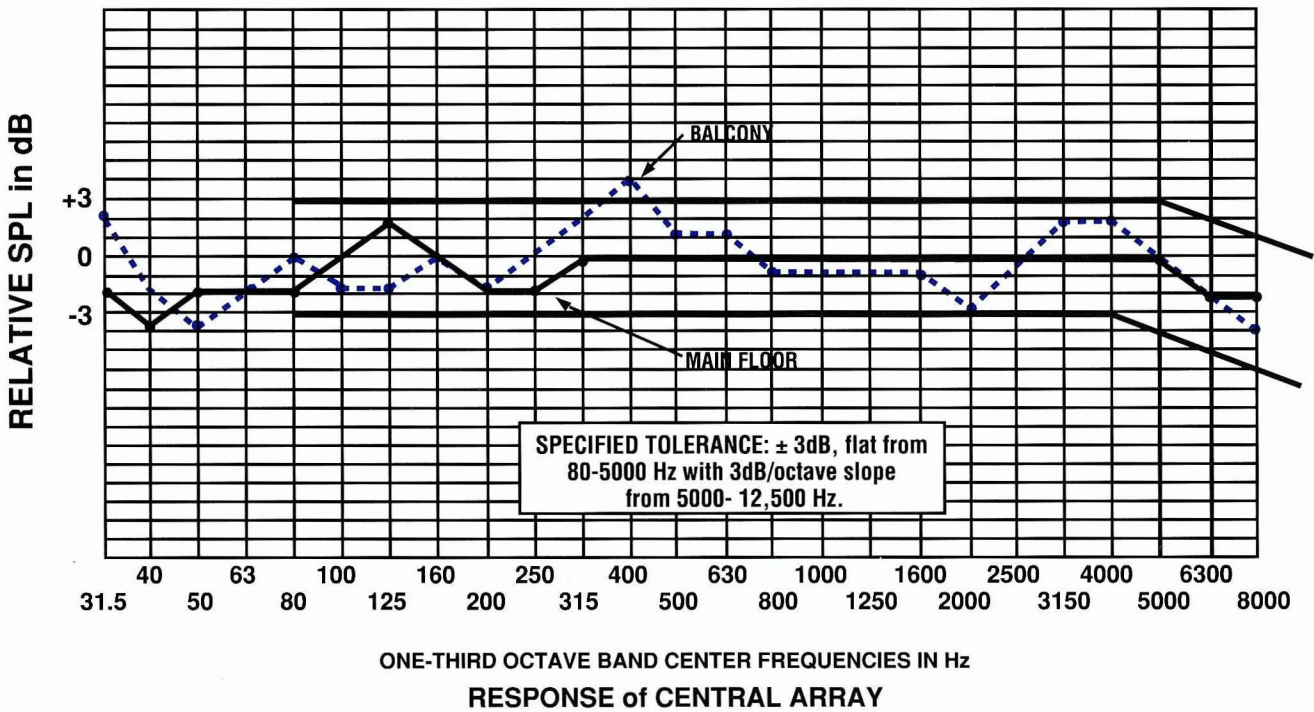
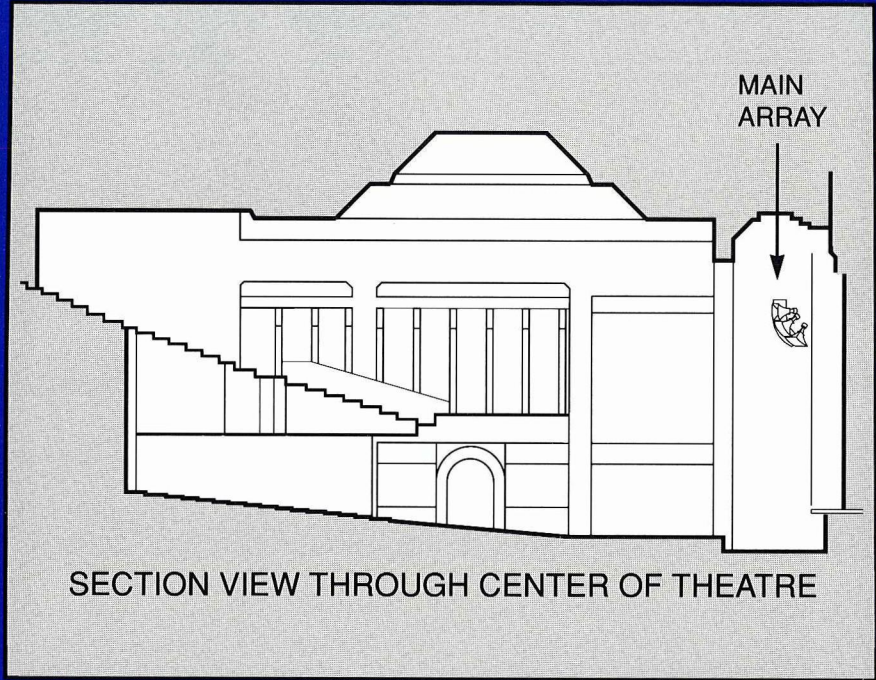

SEATTLE'S 5th AVENUE THEATRE

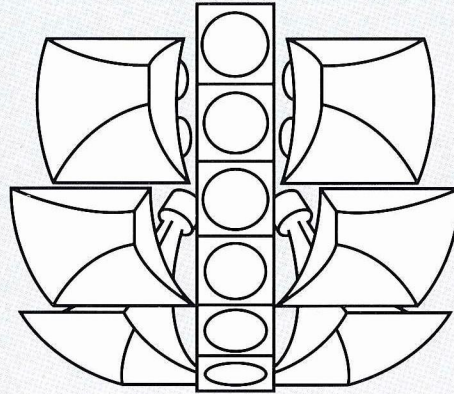

FRONT VIEW

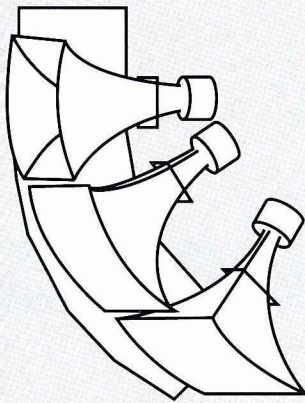

SIDE VIEW

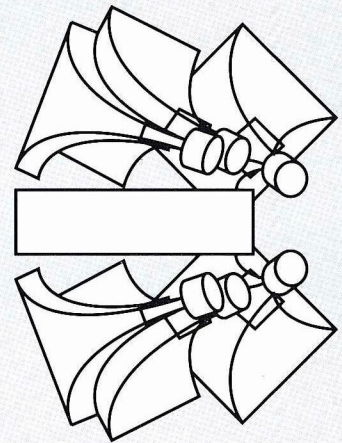

TOP VIEW

CREDITS:

Sound System Design:

Larry King,
Klepper Marshall King Associates, Ltd.,
White Plains, New York

Installation:

Electrocom Sound and Communications
Systems, Seattle, Washington

Management and Operation:

The 5th Avenue Theatre Management
Company, Seattle, Washington

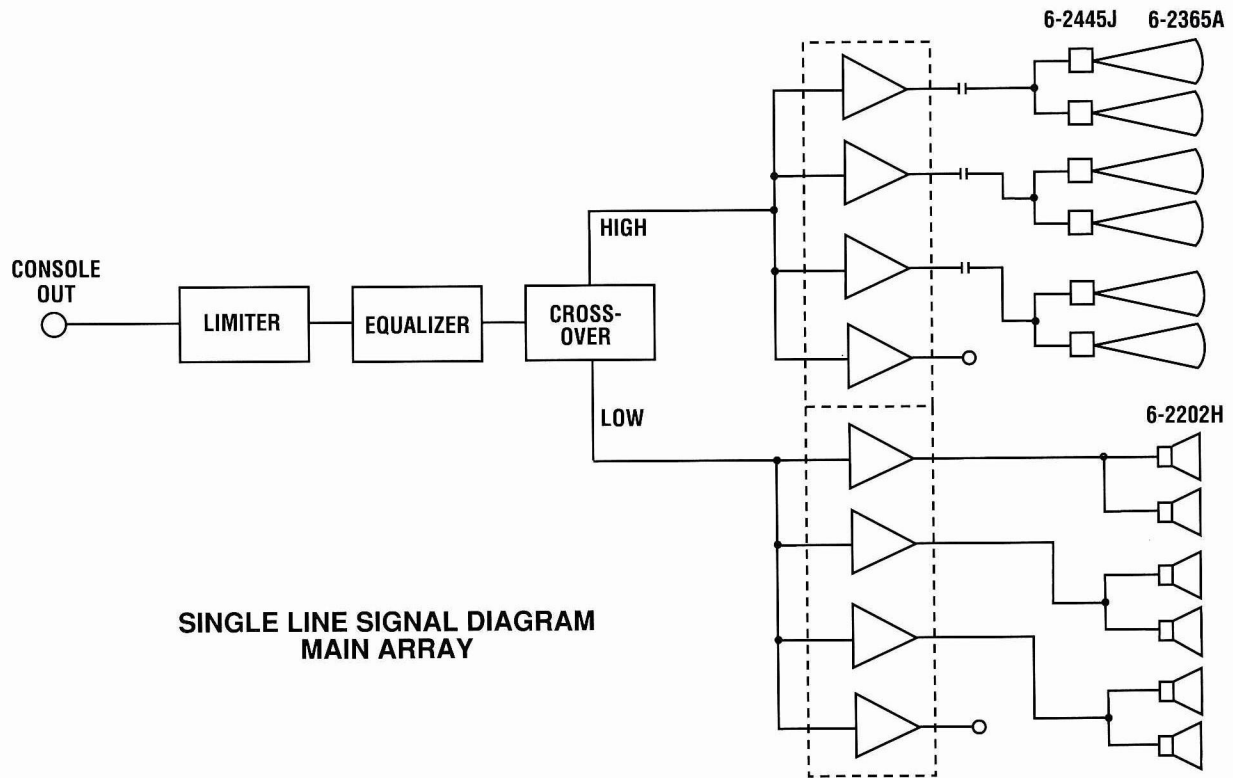

SINGLE LINE SIGNAL DIAGRAM
MAIN ARRAY



JBL Incorporated
8500 Balboa Boulevard
Northridge, California 91329, USA