



JBL Dance Club Systems

*Ministry of Sound | Pacha | Roxy | China Club | Platinum Live | Matrix | Liquid
ARQ | Empire | Cellar Club | Deluxe | Drink | P1 | The Church
Frame | Gaia | Alphabet | Aura | Genesis | B.B.King's Blues Club
On Broadway | Club Deep | Code | Gas | Le Rotonde di Garlasco
Ministry Bar | Luz De Gaz | Capitale | Ruby Skye | Ministry of Sound
Platinum Live | Matrix | Liquid | Es Paradis Terrenal | ARQ | Empire
The Church | Octane | Club Tru | Glam Club | Frame | Gaia | Alphabet
On Broadway | The Bed Room | Katatonic | On Broadway | Club Deep
Crobar | Loop | Privilege | Barock | The Ministry Bar | Luz De Gaz
Pacha | Roxy | China Club | Platinum Live | Matrix | Liquid
Empire | Cellar Club | Deluxe | Drink | P1 | The Church | Octane
Alphabet | Aura | Genesis | B.B.King's Blues Club | The Bed Room | Katatonic |
On Broadway | Code | Gas | Le Rotonde di Garlasco | Crobar | Loop | Privilege | Barock |
Luz De Gaz | Capitale | Ruby Skye | Ministry of Sound | Pacha | Roxy | China Club |
Liquid | Es Paradis Terrenal | ARQ | Empire | Cellar Club | Deluxe | Drink | P1 |
The Church | Octane | Club Tru | Glam Club | Frame | Gaia | Alphabet | Aura | Genesis | B.B.King's Blues*



PROFESSIONAL

JBL DANCE CLUB SYSTEMS

JBL Professional is the premium loudspeaker choice for the world's most electrifying dance club experiences. Combining state-of-the-art technology with revolutionary engineering designs, it's no wonder top dance club owners rely on JBL Professional to rock their house.

Uncompromising Reliability

The night-after-night demands of dance club sound can be brutally punishing on a loudspeaker system. That's why JBL Professional maintains the highest reliability standards in the industry, subjecting all its loudspeaker designs to a rigorous 100-hour torture test, with peak power of 4 times the continuous rated power. Subjecting the speaker to more stress and strain than a loudspeaker would ever experience in actual use, all JBL Professional designs on the market must survive this grueling test. No one in the industry uses a more demanding standard.

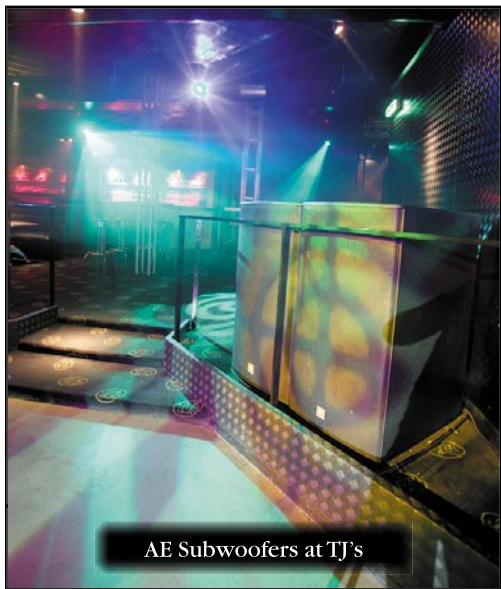

AE Subwoofers at TJ's

Total Selection

As you glance through this booklet you will see that JBL has a speaker for every dance club need. From ear-splitting mega dance floors to tranquil VIP lounges; from eclectic chill rooms to complex sound booths. The Dance5, Dance3 and CBT Supertweeter Arrays, designed specifically for the extreme requirements of large and mega-size

clubs, are the best dedicated dance club loudspeakers in the industry. AE Series features scalable systematic loudspeaker designs for smaller venues, while the VerTec Series brings the live concert experience to the dance club featuring tour-proven loudspeakers used by top musicians from around the world. And the Control Contractor Series, ideal for tight corners and tough angles, combines high performance and rugged construction with compact design. JBL has the answer for all your dance club needs.

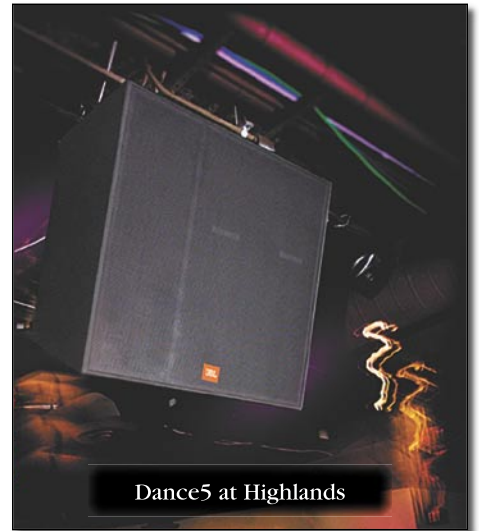

Dance5 at Highlands

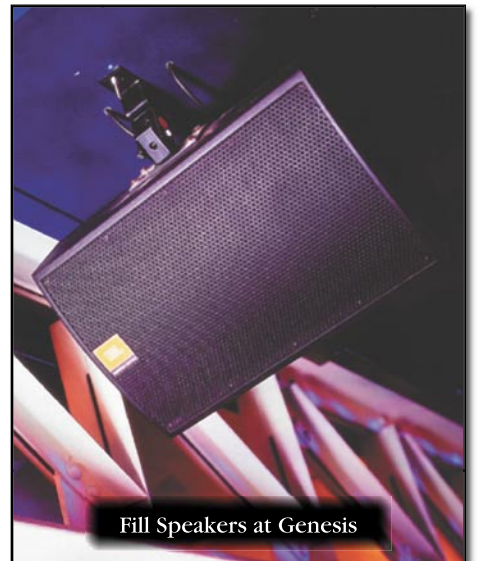

Fill Speakers at Genesis



Dance5 Mains & Control 29AV
Fills at Copacabana

DANCE CLUB EXAMPLES

Ministry of Sound: Bangkok, Thailand.....	Page 5
Copacabana: New York, NY	Page 5
Pacha: London, UK.....	Page 5
The Highlands: Hollywood, CA	Page 5
Capitale: New York, NY	Page 6
TJ's: Eastbourne, UK.....	Page 6
Roxy: New York, NY	Page 6
P1: Munich, Germany.....	Page 6



Ministry of Sound: Bangkok, Thailand

The Ministry is split across three floors comprising a separate dance area on the ground floor, a vast main arena on the first floor and a VIP room on the balconied second floor. JBL product includes: VerTec, Installation Range (now updated to AE Series) and Control Contractor Series. Installed by Satellite Pro A/V.

“This club raises the standard for Bangkok’s fast-paced entertainment industry. When you first encounter the sound system in the main room, you are blown away by the physical power, but the real beauty is its finesse. Even at maximum 120 dB output you can still hold a conversation - which is a sign of the low distortion and the headroom built into the design. What you have is a very high fidelity club experience - a big hi-fi set with massive bass.”

Kenny Jackel of Bangkok-based Satellite Pro A/V
(Mondo*dr May/June 2002)



Copacabana: New York, NY

The world famous Copacabana, the most elegant nightclub in New York boasts a 1200 square meters (13,000 square feet) main area with a 540 square meters (5840 square feet) dance floor, VIP seating area and stage, along with a separate 440 square meters (4800 square feet) Disco Room. JBL product includes: VerTec, Custom Subwoofers, Dance 5, AE Series and Control 29AV.



Pacha: London, UK

Pacha has two rooms and three bars, with no walls between the two main spaces, so particular attention to detail was paid to ensure sound spillage between areas was minimized. JBL product includes: Installation Range (now updated to AE Series) in the main rooms and Control Contractor Series in the entrance lobby and toilets. Installed by Pete Dyer of Tarsin.

Pete Dyer of Tarsin, well known for designing, supplying and installing sound systems to some of the highest profile clubs in the UK and worldwide, says he will always recommend JBL for its reliability, longevity and minimum maintenance requirements - an important consideration when also servicing any system on an ongoing basis.

(Arbiter Pro Press Release, Feb 8, 2002)



The Highlands: Hollywood, CA

Located at the historical corner of Hollywood Boulevard and Highland Avenue, the Highlands nightclub is a state-of-the-art, multi-faceted venue spanning two floors and 2800 square meters (30,000 square feet). The club can entertain up to 1300 guests and boasts four separate dining areas, seven bars, two dance floors, two performance stages and four outdoor patios that offer stunning views of the Los Angeles basin. JBL product includes: Dance 5s with AE Series subwoofers for the main dance floor, Control 29AVs and 30s for seating, outdoor restaurant and entrance/queue area.

“We were looking to set ourselves a notch above the competition. We chose JBL because we knew that the performance, reliability, and sound of the speakers would be excellent. Our customers are constantly commenting on how awesome the system sounds. We have a sound system that is on a whole new level all by itself. There is no doubt, because we chose JBL.”
- Billy Thornton, Production Manager, Highlands, Hollywood, CA.



Capitale: New York, NY

The new Capitale event facility in New York is a multi-room venue including a 1500-person capacity ballroom dance area, 160-person restaurant, four private rooms and two executive rooms. JBL product includes: VerTec and AE Series. Installed by Trio Audio.

“Out of the five brands I auditioned, JBL sounded the best, with clean sharp presence in the highs, definitive mids without the distortion or “honkiness”, and a tight low end without boominess. Plus, when you buy a JBL speaker system, you get JBL drivers!” -Sam Yee of Trio Audio Inc, Designer and Installer, Capitale, New York.



TJ's: Eastbourne, UK

TJ's is an intimate 375 capacity, independently owned club, which has been in business for the last 20 years. It's one of the best known and most respected landmark venues in the area and is the first UK venue to receive JBL's powerful, new, low profile AE series installation speakers. Installed by Accord Audio.

Delighted with the sonic results, TJ's manager Andy Malyon stated, “Loads of customers have commented how great it sounds since we had the system installed - and you can't get better endorsement than that!” (Lighting & Sound International, Feb. 2003)



Roxy: New York, NY

New York's best venue for dancing and roller-skating, the Roxy is a roller-rink turned superclub. This legendary club also offers an exciting facility for hosting corporate events and concerts. JBL product includes: JBL-loaded Phazon speakers. Installed by Walter Mosetter of Philadelphia Sound and renowned engineer Steve Dash.

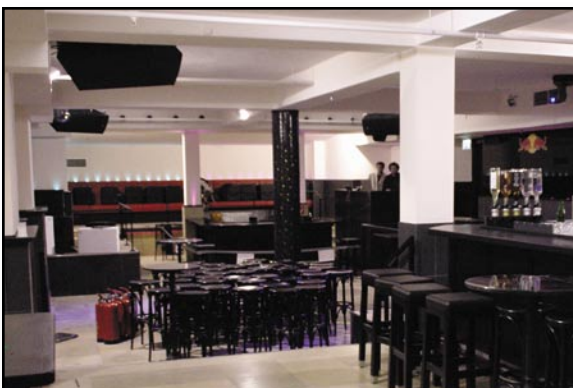

P1: Munich, Germany

Opened originally as an Officers Club for the US Army in 1949, P1 is one of the most prestigious clubs in Germany. Located in the Haus der Kunst (House of Arts), the club is open 365 days a year and has only been closed 3 days over the last 20 years due to renovations. JBL products include: Custom Shop, AE Series and Control Series. Installed by Licht-Ton-Elektrotechnik.

DANCE CLUB TEMPLATES

Template 1: Small Dance Floor	Page 9
Template 2: Medium Dance Floor	Page 10
Template 3: Large Dance Floor	Page 11
Template 4: Mega Dance Floor.....	Page 12
Template 5: Live Performance System	Page 13
Ancilliary Areas	Page 14
System Example, Copacabana, New York	Page 15
System Example, Typical Superclub Signal Flow Diagram	Page 16 & 17

Template #1: **Small Dance Floor**

(less than 30 sq meters / 320 sq ft)

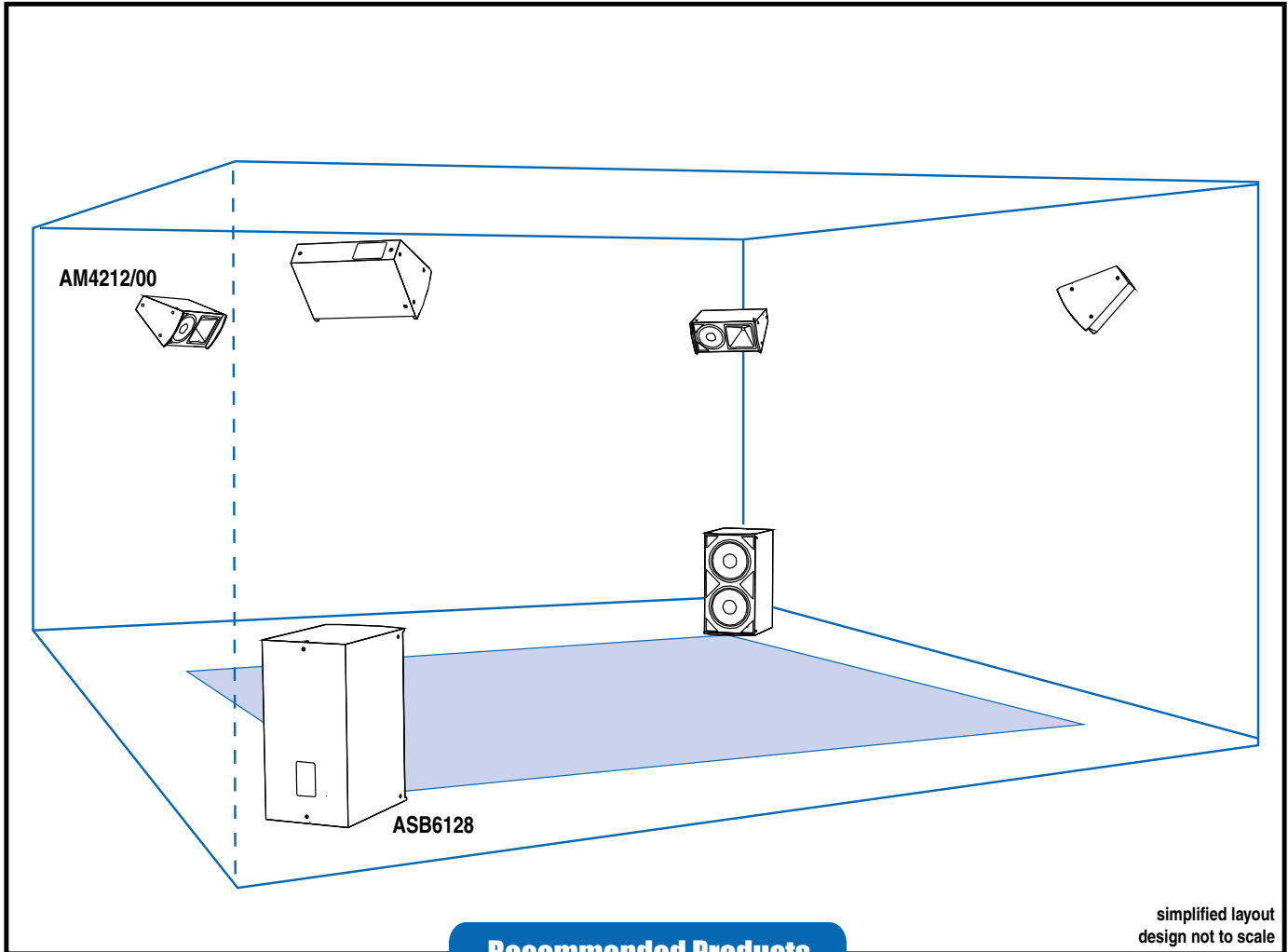

Recommended Products

simplified layout
design not to scale

Full-Range Speakers

AM4212/00
medium-power, 12", 2-way loudspeaker

or

AC2212/00
compact, 12", 2-way loudspeaker

Subwoofers

ASB6128
high-power, dual 18", subwoofer

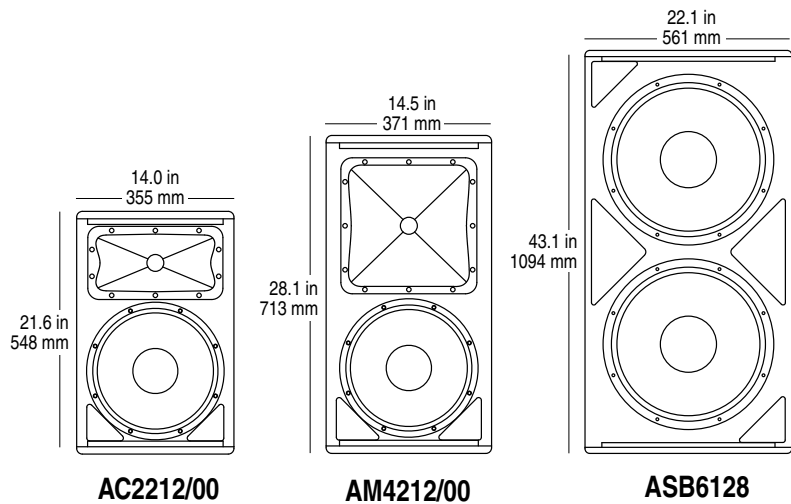

Template #2: Medium Dance Floor
 (30-100 sq meters / 320-1100 sq ft)

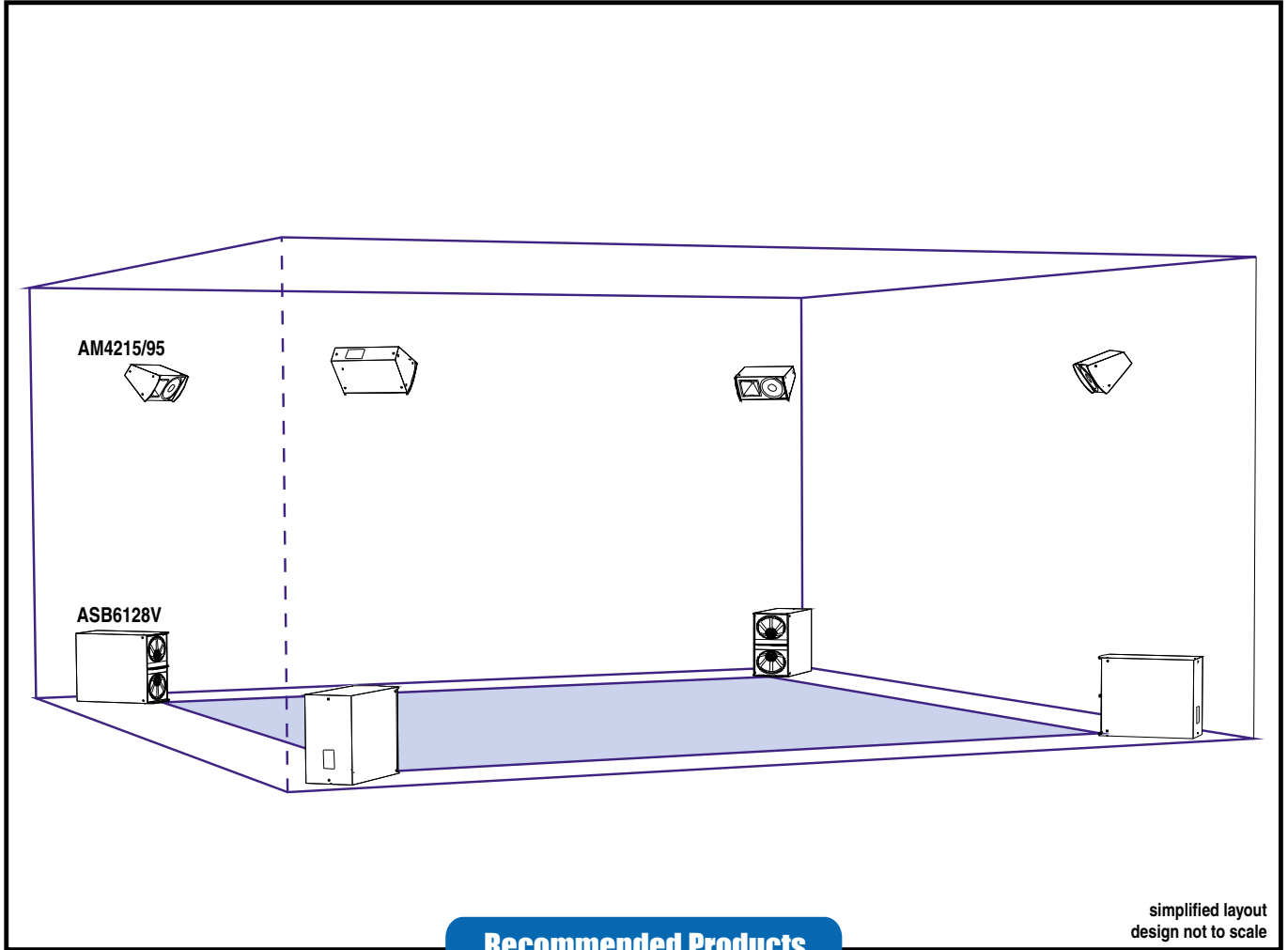

Recommended Products

Full-Range Speakers

AM4215/95
 medium-power, 15", 2-way loudspeaker

or

AC2215/95
 compact, 15", 2-way loudspeaker

Subwoofers

ASB6128V
 extended response, high-power, dual 18", sub

or

ASB6128
 high-power, dual 18" subwoofer

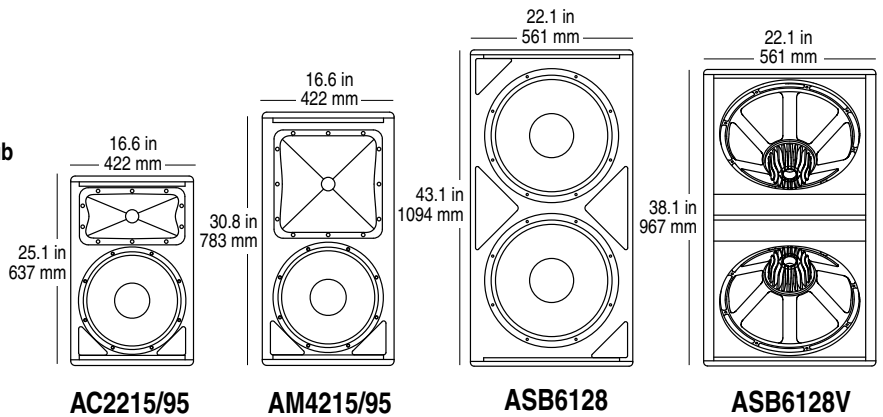

Template #3: Large Dance Floor
 (100-200 sq meters / 1100-2200 sq ft)

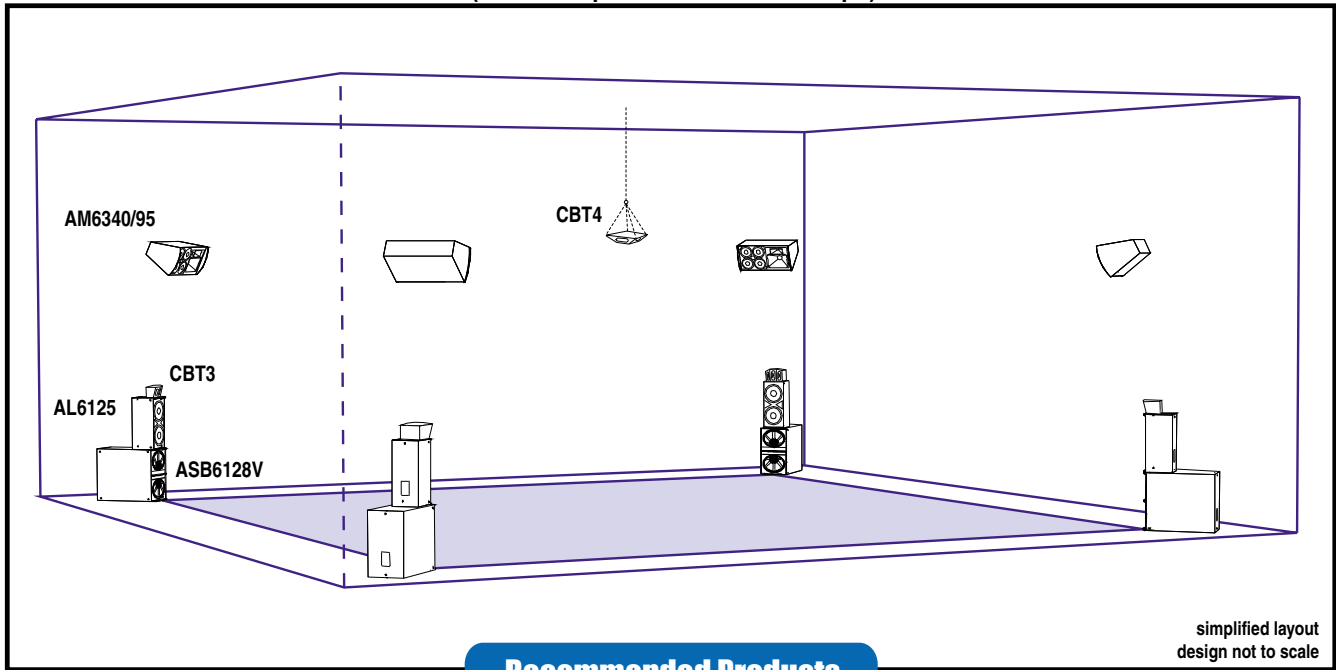

Recommended Products

Full-Range Speakers

AM6340/95
 high-power, 4 x 10", 3-way loudspeaker

or

Dance3
 high-output, side-mounted dual 15", 3-way loudspeaker

or

Dance5
 high-output, dual 8" MF, 3 x 14" LF, 3-way loudspeaker

Low-Frequency Speaker (optional)

AL6125
 high-power, dual 15", LF loudspeaker

Supertweeter (optional)

CBT4 (ceiling suspended)
 multiple, ultra-high frequency horns

or

CBT3 (stacked)
 multiple, ultra-high frequency horns

Subwoofer

ASB6128V
 extended response, high-power, dual 18", subwoofer

or

ASH6118
 high-power, 18", horn-loaded subwoofer

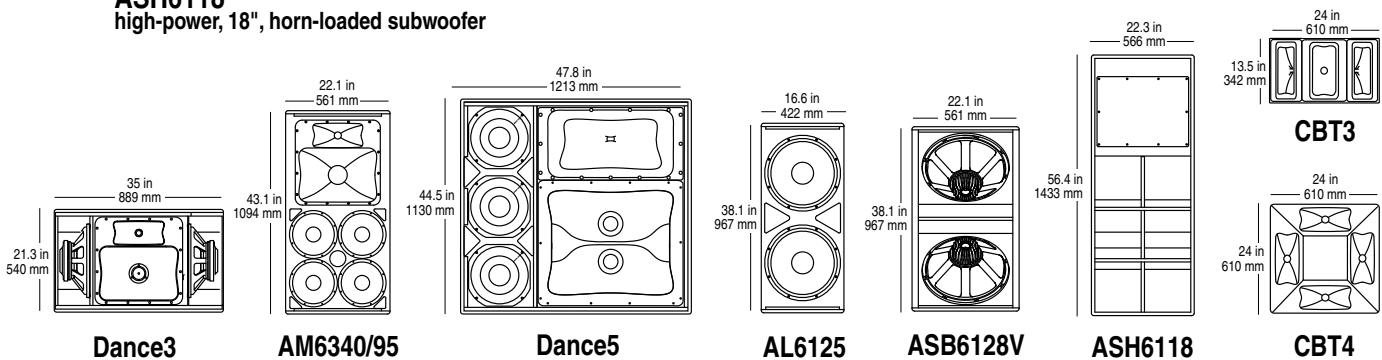

*Dance3 and Dance5 models are built to order

Template #4: Mega Dance Floor

(over 200 sq meters / 2200 sq ft)

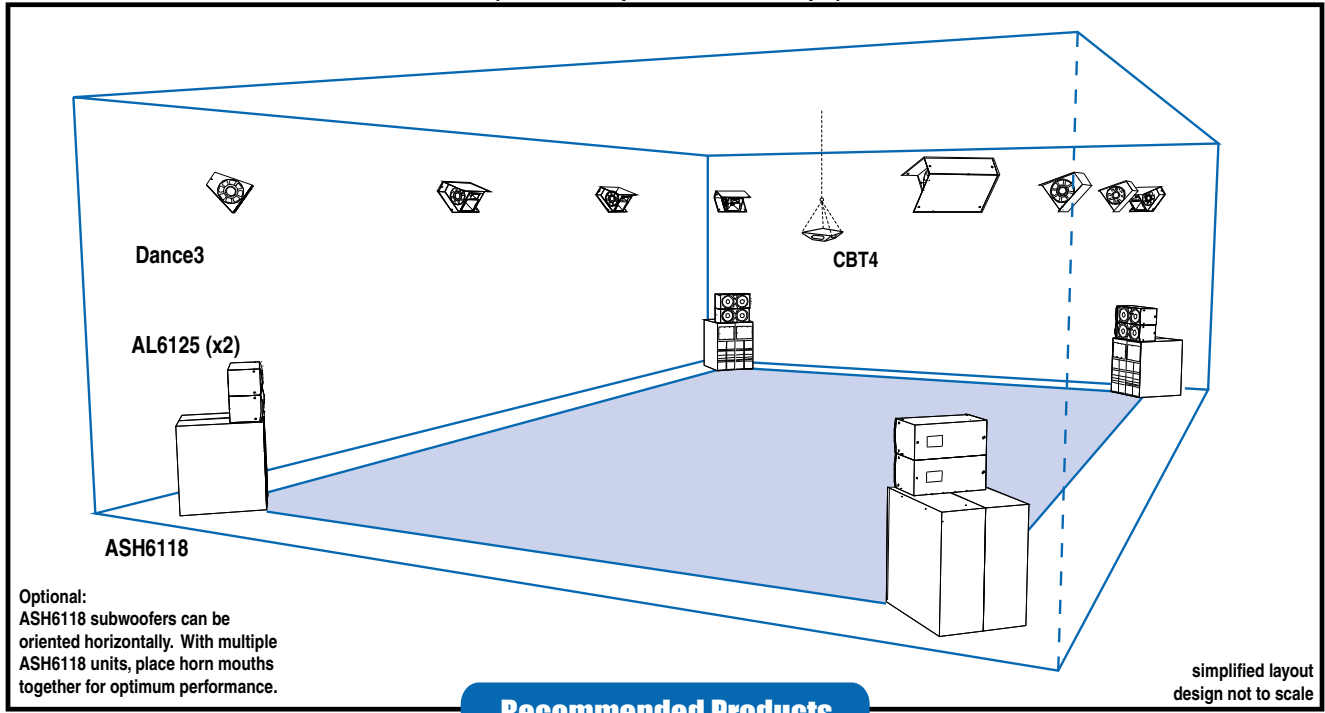

Recommended Products

Full-Range Speakers

- Dance3**
high-output, side-mounted dual 15", 3-way loudspeaker
- or
- Dance5**
high-output, dual 8" MF, 14" LF, 3-way loudspeaker
- or
- VT4889**
high-power, dual 15", 3-way line array loudspeaker
- or
- VT4888**
compact, high-power, dual 12", 3-way line array loudspeaker

Subwoofers

- ASH6118**
high-power, 18", horn-loaded subwoofer
- or
- ASB6128V**
extended response, high-power, dual 18", subwoofer

Supertweeter (optional)

- CBT4** (ceiling suspended)
multiple, ultra-high frequency horns
- or
- CBT3** (stacked)
multiple, ultra-high frequency horns

Low-Frequency Speakers (optional)

- AL6125**
high-power, dual 15", low-frequency loudspeaker

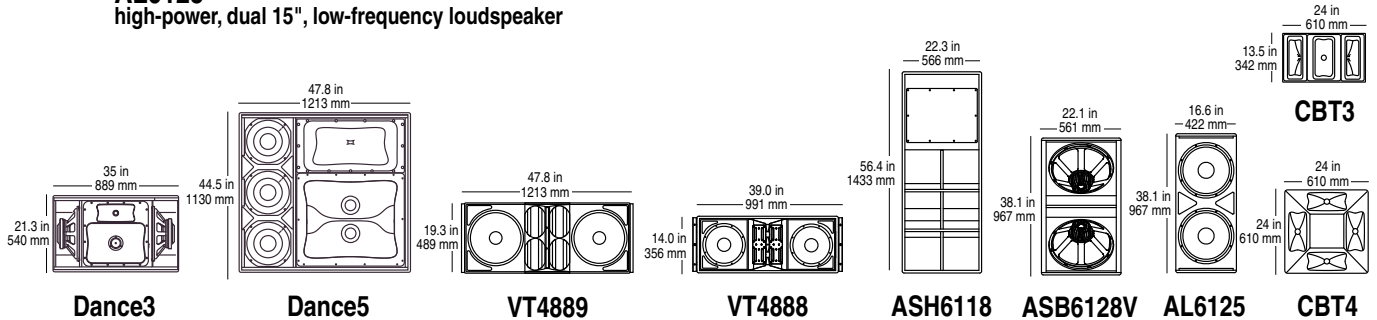

*Dance3 and Dance5 models are built to order

Template #5: Live Performance System

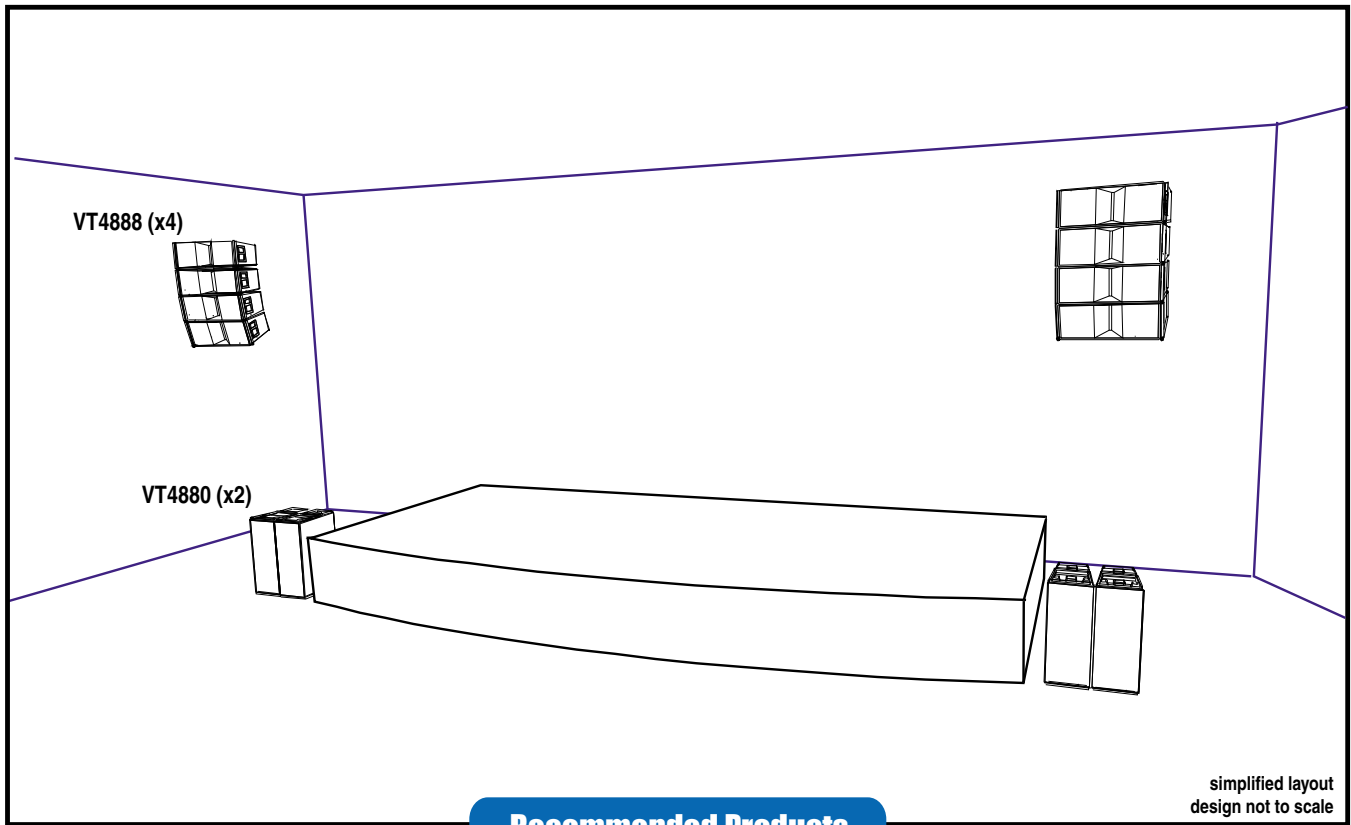

Recommended Products

Full-Range Speakers

VT4888
compact, high-power, dual 12", 3-way line array loudspeaker

or

AM6340/95
high-power, 4 x 10", 3-way loudspeaker

Subwoofers

VT4880
high-power, dual 18", arrayable subwoofer

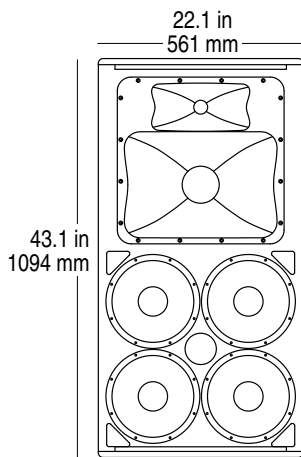

AM6340/95

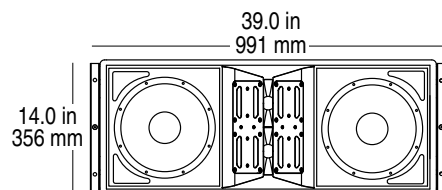

VT4888

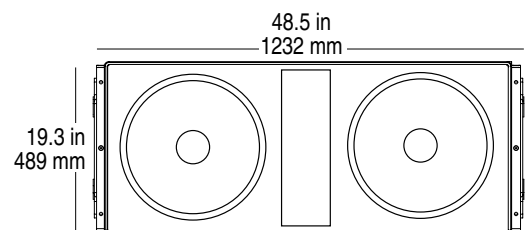

VT4880

JBL Products for Ancilliary Areas

Bar Fill / VIP Lounge

Very High Level

AC2212/00

compact, 12", 2-way loudspeaker

or

AM6212/00

high-power, 12", 2-way loudspeaker

High Level

Control 30

compact, 10", 3-way loudspeaker

or

Control 29AV

high-power, 8", 2-way loudspeaker

Low Level

Control 25AV

compact shielded, 5.25", 2-way monitor speaker

Ceiling Speakers

Control 26CT

high-power, 6.5", 2-way ceiling speaker

Private VIP Rooms

SMS1 System

premium self-contained business music sound system

Booth Monitors

Small

EON10 G2

self-powered, 10", 2-way, portable loudspeaker

Medium

EON15 G2

self-powered, 15", 2-way, portable loudspeaker

Large

AM6215/95

high-power, 15", 2-way, loudspeaker

Chill Room

Control 25AV

compact shielded, 5.25", 2-way monitor speaker

or

Control 26CT

high-power, 6.5", 2-way ceiling speaker

Entranceway / Queue Area

Control 25AV

compact shielded, 5.25", 2-way monitor speaker

System Example: The Copacabana in New York City



3-D View

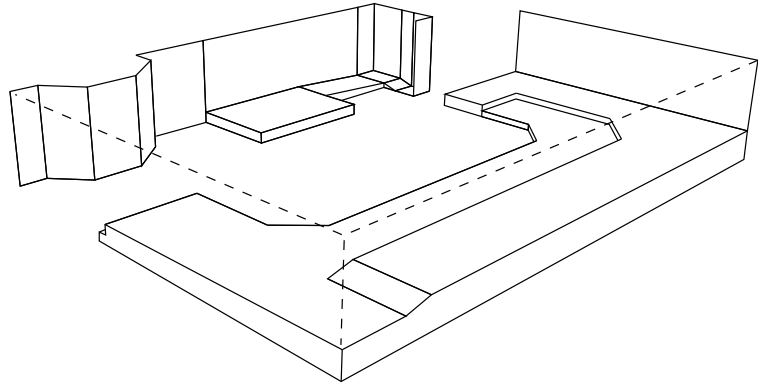

Top View

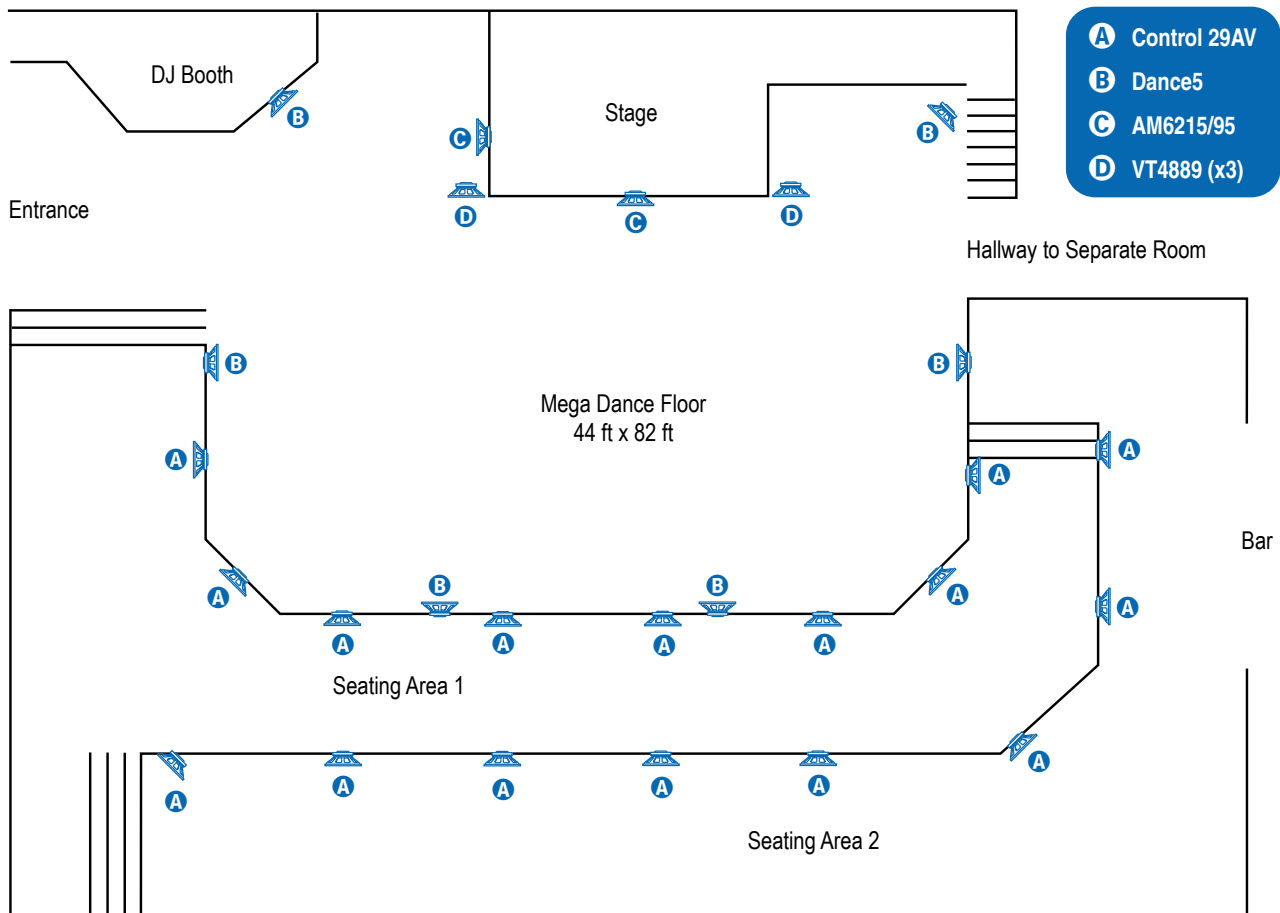

Typical Superclub Signal Flow Diagram

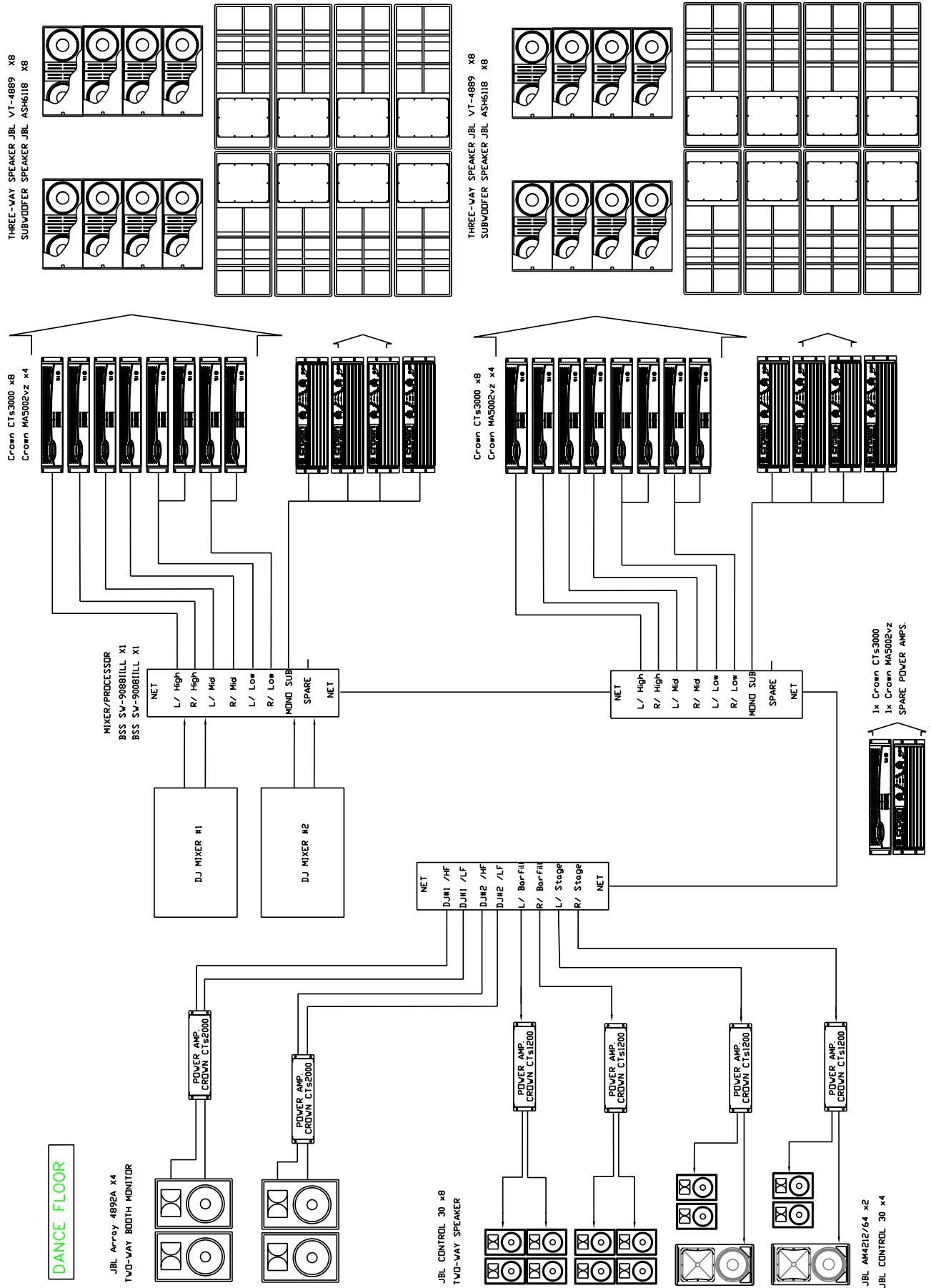

Typical Superclub Signal Flow Diagram

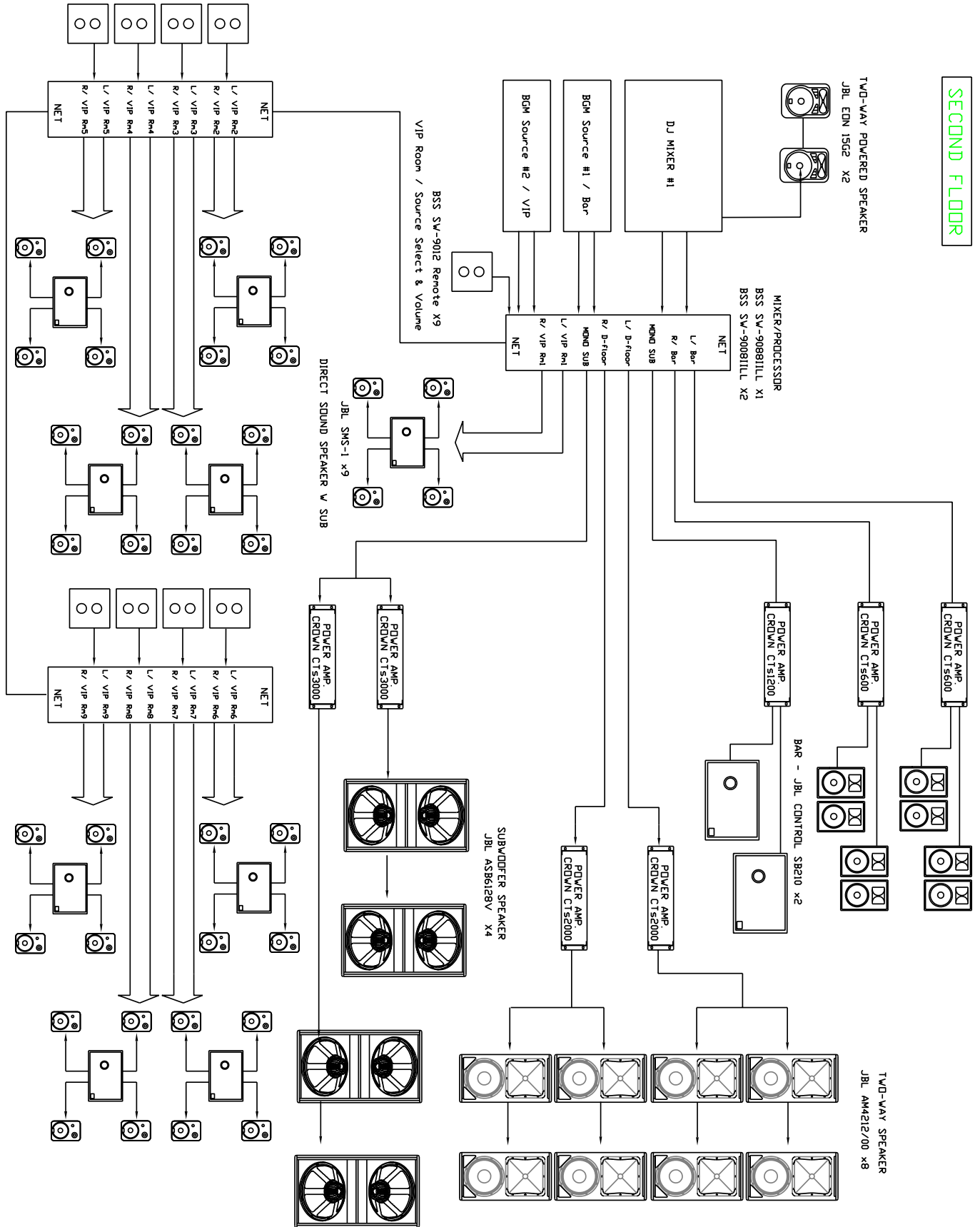

PRODUCT REFERENCE

MAIN LOUDSPEAKERS

Dance5	Page 19
Dance3	Page 20
VT4889	Page 21
VT4888	Page 22
AM6340/95	Page 23
AM6215/95	Page 24
AM4215/95	Page 25
AM4212/00	Page 26
AC2215/00	Page 27
AC2212/00	Page 28

SUBWOOFERS & LF CABINETS

ASH6118.....	Page 29
ASB6128V	Page 30
ASB6128	Page 31
AL6125	Page 32

SUPER TWEETERS

CBT4.....	Page 33
-----------	---------

BOOTH, FILL, CHILL & ENTRANCE LOUDSPEAKERS

EON10 G2	Page 34
EON15 G2	Page 35
CONTROL 30.....	Page 36
CONTROL 29AV.....	Page 37
CONTROL 25AV.....	Page 38
CONTROL 26C/CT.....	Page 39
SMS1	Page 40 - 43



Dance5

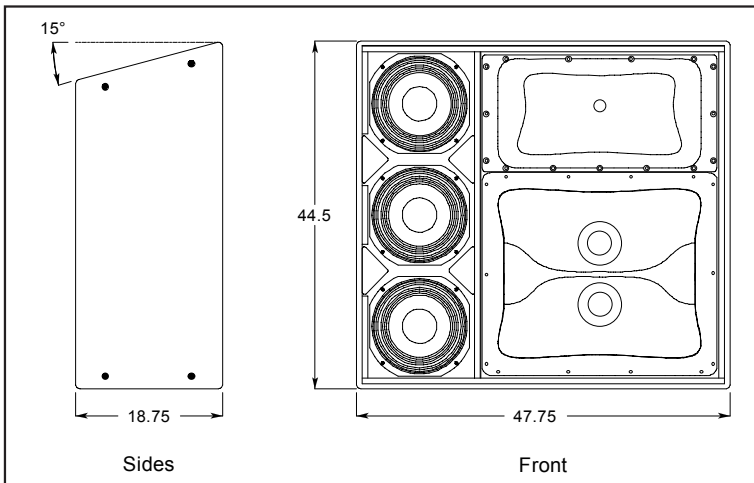

Specifications:

System:

Frequency Range (-10 dB):	35 Hz - 18 kHz
Frequency Response (± 3 dB):	50 Hz - 16 kHz
Horizontal Coverage Angle (-6 dB):	90° averaged 500 Hz to 16 kHz
Vertical Coverage Angle (-6 dB):	50° (+20°, -30°) averaged 500 Hz to 16 kHz

Transducers:

Low Frequency:	3x 2217HPL, 355 mm (14 in) dia., 100 mm (4 in) edge wound ribbon voice coil
Nominal Impedance:	8 Ohms each 3.2 Ohms with 3 drivers wired in parallel
Power Rating:	600 Watts AES, 2400 Watts peak each driver 1800 Watts AES, 7200 Watts peak total
Sensitivity ¹ :	101 dB SPL, 1W @ 1m (3.3 ft)
Calculated Maximum Peak SPL:	140 dB SPL @ 1m (3.3 ft)
Mid-Frequency:	2x 2169H, 200 mm (8 in) dia., NDD, 2x 76 mm (3 in) edge wound ribbon voice coil
Nominal Impedance:	4 Ohms
Power Rating:	700 Watts AES, 2800 Watts peak
Sensitivity ¹ :	108 dB SPL, 1W @ 1m (3.3 ft)
Calculated Maximum Peak SPL:	142 dB SPL @ 1m (3.3 ft)
High Frequency:	2451H; 100 mm (4 in) diaphragm and voicecoil, 38 mm (1.5 in) throat; 2384 PT Waveguide
Nominal Impedance:	8 Ohms
Input Power Rating:	75 Watts AES; 300 W Peak
Sensitivity ¹ :	114 dB, 1 W @ 1 m (3.3 ft)
Calculated Maximum SPL:	139 dB @ 1 m (3.3 ft)

Physical:

Enclosure:	Rectangular with 15° top angle; birch plywood
Suspension Attachment:	18 points - 4 top & each side, 5 bottom, 1 rear; M10 thread pattern
Finish:	Black DuraFlex coating (white optional)
Grille:	Black powder coated 16 gauge perforated steel with black foam backing (white optional)
Input Connector:	Barrier strip & Neutrik Speakon
Dimensions (H x W x D):	1130 mm x 1213 mm x 476 mm (44.5 in x 47.75 in x 18.75 in)
Net Weight:	88.6 kg (195 lb)

¹ Anechoic sensitivity, within normal bandpass of system or section of system, in free field; does not assume any additional sensitivity gain from boundary loading.

JBL continually engages in research related to product improvement. Some materials, production methods and design refinements are introduced into existing products without notice as a routine expression of that philosophy. For this reason, any current JBL product may differ in some respect from its published description, but will always equal or exceed the original design specifications unless otherwise stated. 5/2/03 ATR

Dedicated Dance Club Design

High Output Three-Way System

Horn-loaded Mid and High

Dual 8" Cone Midrange Horn

Triple 14" Low Frequency

Key Features:

- ▶ Three 2217H 14" VGC (Vented Gap Cooled™) LF transducers
- ▶ Dual Horn-loaded 2169H NDD (Neodymium Dual Drive™) 8" cone midrange drivers
- ▶ 2384 PT (Progressive Transition™) HF Waveguide
- ▶ 2451H Neodymium magnet, 4" diaphragm compression driver
- ▶ Cutaway top enclosure allows mounting closer to ceiling
- ▶ Full complement of suspension points simplify installation

The Dance5 is a premier member of JBL's purpose-designed dance club family of products. Designed with enough low frequency horsepower to rock any house, smooth sweet sounding horn-loaded cone midrange and the extreme high frequency performance that JBL is famous for.

When combined with JBL subwoofers, the Dance5 forms the core of a world-class large-club system

The Dance5 can be flown using integral suspension attachment points or ground-stacked atop subwoofers

The Dance5 is designed for tri-amplified use. Use of the BSS Soundweb, dbx Driverack or similar digital controller for crossover, signal alignment, limiting and equalization is required for optimum performance.

The Dance5 is built when ordered. Contact your local sales representative for information on lead time.



Dance3

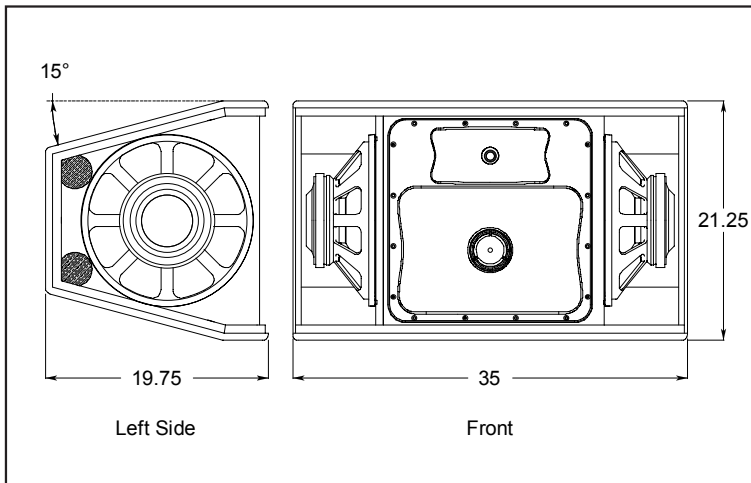

Specifications:

System:

Frequency Range (-10 dB):	45 Hz - 18 kHz
Frequency Response (± 3 dB):	60 Hz - 16 kHz
Horizontal Coverage Angle (-6 dB):	90°
Vertical Coverage Angle (-6 dB):	50°

Transducers:

Low Frequency:	2x 2226H, 380 mm (15 in) dia., 100 mm (4 in) edge wound ribbon voice coil
Nominal Impedance:	4 Ohms
Power Rating:	1200 Watts AES, 4800 Watts peak
Sensitivity:	100 dB SPL, 1W @ 1m (3.3 ft)
Calculated Maximum Peak SPL:	137 dB SPL @ 1m (3.3 ft)
Mid-Frequency:	1x CMCD-81H, 200 mm (8 in) dia., NDD, 2x 76 mm (3 in) edge wound ribbon voice coil
Nominal Impedance:	8 Ohms
Power Rating:	350 Watts AES, 1400 Watts peak
Sensitivity:	108 dB SPL, 1W @ 1m (3.3 ft)
Calculated Maximum Peak SPL:	139 dB SPL @ 1m (3.3 ft)
High Frequency:	2431H; 75 mm (3 in) diaphragm and voicecoil, 38 mm (1.5 in) throat
Nominal Impedance:	8 Ohms
Input Power Rating:	75 Watts AES; 300 W Peak
Sensitivity:	113 dB, 1 W @ 1 m (3.3 ft)
Calculated Maximum SPL:	138 dB @ 1 m (3.3 ft)

Physical:

Enclosure:	Vertically trapezoidal with 15° top & bottom angles; birch plywood
Suspension Attachment:	6 points - 2 each top, bottom & rear; M10 thread pattern
Finish:	Black DuraFlex coating (white optional)
Grille:	Covers front & wraps around both ends of enclosure; Black powder coated 16 gauge perforated steel with black foam backing (white optional)
Input Connector:	Barrier strip & Neutrik Speakon
Dimensions (H x W x D):	540 mm x 889 mm x 502 mm (21.25 in x 35 in x 19.75 in)
Net Weight:	56.8 kg (125 lb)

¹ Anechoic sensitivity, within normal bandpass of system or section of system, in free field; does not assume any additional sensitivity gain from boundary loading.

JBL continually engages in research related to product improvement. Some materials, production methods and design refinements are introduced into existing products without notice as a routine expression of that philosophy. For this reason, any current JBL product may differ in some respect from its published description, but will always equal or exceed the original design specifications unless otherwise stated. 5/3/03 ATR

Dedicated Dance Club Design

Maximum Output/Minimum Size

Three-Way System

Horn-loaded Mid and High

Dual 15" Low Frequency

Key Features:

- ▶ Two 2226H 15" VGC (Vented Gap Cooled™) LF transducers
- ▶ Horn-loaded CMCD™ (Cone Midrange Compression Driver™)
- ▶ PT (Progressive Transition™) MF/HF Multiband Waveguide
- ▶ 2431H Neodymium magnet, 3" diaphragm compression driver
- ▶ Unique end-firing LF evenly distributes energy & minimizes enclosure size

The Dance3 is a premier member of JBL's purpose-designed dance club family of products. With amazing low frequency power, smooth CMCD midrange and the extreme high frequency performance that JBL is famous for, combine with JBL sub-woofers for the ultimate mid-size system.

The unique end-firing LF design of the Dance3 assures wide, even coverage of low frequencies while allowing for an enclosure that is much smaller than otherwise possible. The perforated steel grille of the Dance 3 wraps completely around both ends of the enclosure for a high-tech, yet understated appearance.

Dance3 is intended to be suspended overhead. The compact, vertically trapezoidal enclosure allows sufficient headroom even in low-ceiling applications.

Dance3 is designed for bi- or tri-amplified use. Use the BSS Soundweb, dbx Driverack or similar digital controller for optimum performance.

The Dance3 is built when ordered. Contact your local sales representative for information on lead time.



VT4889 Three-Way High Directivity Line Array Element

VERTEC™ Series

Application:

The VT4889 Three-Way Line Array Element is designed to deliver high-quality reinforcement of music and speech in a variety of applications including concert audio and corporate A/V presentations of all types.

Key Features:

- ▶ Advanced technology components: Neodymium Differential Drive®, neodymium magnet, dual voice coil, Direct Cooled™ cone transducers for low weight and high output
- ▶ Industry's smallest, lightest, most powerful 1.5" exit, 3" diaphragm high-frequency compression driver
- ▶ WaveFormer™ units couple to create precision HF vertical slot aperture
- ▶ Radiation Boundary Integrator® (R.B.I.): Patent-pending technology integrates output of individual bandpass elements
- ▶ Advanced construction techniques and hybrid materials provide exceptionally rigid, lightweight enclosure construction
- ▶ Rugged DuraFlex™ exterior finish; weatherized components
- ▶ Integrated S.A.F.E.™ suspension system: premium heat-treated alloys provide rigid, reliable hanging arrays

The above features come together in a line array system with performance advantages offering benefits for both portable system users and fixed-venue installations. The VT4889 combines time-tested acoustical physics with JBL's innovative transducer research and design in a premium-grade system package. JBL's VERTEC (Vertical Technology) builds on proven line array theory as demonstrated in JBL's line array systems in the early 1970's.

The VT4889 is a rugged, lightweight enclosure housing two 15" woofers, four 8" midrange radiators, and three high-frequency compression drivers. These advanced components provide the highest power-to-weight ratio of any speaker system in its class.

Enclosure features foam-backed low-frequency grilles, dense protective foam inserts for midrange apertures, and a fine steel mesh grille to protect high-frequency apertures. All speaker cones are treated with weather-resistant compounds. Rigging frames and hinge bars are made from premium-grade chromemoly alloy steel, with epoxy power coating over zinc-plated surfaces; hinge pins are



cadmium-plated and quick-release pin restraining lanyards are stainless steel to resist corrosion and weather damage.

VERTEC arrays are rigid for maximum support strength, yet flexible in design and application. The VT4889's suspension hardware relies on quick-release pins and end-mounted metal frames to couple adjacent VT4889's together. Enclosure ships with available front and rear hinge bar set (VT4889-RIG), available padded soft bag (VT4889-COVER) and protective grille cover/wheelboard (VT4889-DOLLY) to ensure handy transport for rough road conditions.

Specifications:

Line Array Element	
Freq. Response (± 3 dB):	45 Hz - 16 kHz
Horizontal Coverage Angle (- 6 dB):	90 deg. nominal, 250 Hz - 16 kHz
Vertical Coverage Angle (- 6 dB):	Varies with array size and configuration
Maximum Peak Output:	136 dB to 146 dB @ 1m (Frequency/bandpass dependent)
Recommended Signal Processing:	Digital System Controller: dbx 480. BSS 366, XTA 226 also supported
Transducer Sections	
Low Frequency:	(2) x 2255HPL, 380 mm (15 in.) dia., 76 mm (3 in.) Dual Coil, Neodymium Differential Drive, Direct Cooled
Nominal Impedance (each driver):	8 ohms, independently wired
Input Power Rating:	1200W, AES, system bandpass (600W per driver)
Bandpass Sensitivity:	99 dB, 1w/1m (3.3 ft.)
Mid Frequency:	(4) x 2250H, 203 mm (8 in.) dia., 76 mm (3 in.) dual coil, Neodymium Differential Drive®, Direct Cooled™
Nominal Impedance (bandpass):	8 ohms, wired series parallel
Input Power Rating:	1200W, AES, system bandpass (300W per driver)
Bandpass Sensitivity:	102 dB, 1w/1m (3.3 ft.) (system bandpass)
High Frequency:	(3) x 2435H, 76 mm (3 in.) dia., beryllium diaphragm voice coil, 38 mm (1.5 in.) throat diameter
Nominal Impedance (bandpass):	16 ohms, wired in series
Input Power Rating:	225W, AES, system bandpass (75W per driver)
Bandpass Sensitivity:	116 dB, 1w/1m (3.3 ft.) (system bandpass)
Enclosure / Suspension Hardware	
Box Construction:	Wedge frustum, 5 degree side angle composite enclosure, DuraFlex finish, 8 handles
Suspension System:	S.A.F.E. hardware, integral hinge bars nest in rigging frames on box ends. Quick release pins with restraining lanyards
Grille:	Separate LF and HF, black, perforated steel. LF grilles foam-backed
Input Connectors:	NLS, 2 each
Dimensions (H x W x D):	489 mm x 1213 mm x 546 mm (19.25" x 47.75" x 21")
Net Weight:	72 kg (159 lbs.) incl. rigging frames & hinge bars
Shipping Weight:	91 kg (200 lbs.) incl. Dolly, Cover, packaging



VT4888

Midsize Tri-Amplified Three-Way High Directivity Line Array Element



VERTEC™ Series

Application:

The VT4888 Three-Way Line Array Element is designed to deliver high-quality reinforcement of music and speech in a variety of applications including concert audio and corporate A/V presentations of all types for both portable users and fixed venue installations.

Key Features:

- ▶ Advanced technology components: Neodymium Differential Drive®, neodymium magnet, dual voice coil
- ▶ Direct Cooled™ cone transducers for low weight and high output
- ▶ Waveguide units couple to create precision HF vertical slot aperture
- ▶ Radiation Boundary Integrator® (RBI): Patented technology integrates output of individual bandpass elements
- ▶ Advanced construction techniques and hybrid materials provide exceptionally rigid, lightweight enclosure construction
- ▶ Rugged DuraFlex™ exterior finish; weatherized components
- ▶ Integrated S.A.F.E.™ suspension system: premium heat-treated alloys provide rigid, reliable hanging arrays
- ▶ Pre-engineered to accept optional amplified electronics package. Rear-panel mechanical attachments and electrical connections ensure upgrade path for DrivePack™ self-powered system modules with integral signal processing
- ▶ For use in stand-alone arrays or in combination with other VERTEC system products

The VT4888 is a rugged, lightweight enclosure housing two 12" woofers, four 5" midrange radiators, and two high frequency compression drivers. Advanced components provide the highest power-to-weight ratio of any speaker system in its class.

Enclosure features foam-backed low frequency grilles, dense protective foam inserts for midrange apertures, and fine steel mesh grille to protect high-frequency apertures. Speaker cones are treated with weather-resistant compounds. Rigging tubes made of hard-black anodized 6061-T6 Aluminum. Hinge bars made from premium-grade chromoly alloy steel, with epoxy powder coating over zinc-plated surfaces. Cadmium-plated hinge pins and stainless steel quick-release pin lanyards to resist corrosion and weather damage.

VERTEC arrays are rigid for maximum support strength, yet flexible in design and application. The VT4888's suspension hardware relies on quick-release pins and end-mounted metal tubes to couple adjacent VT4888's together. Enclosure ships with integral front and rear hinge bar set. Protective grille cover/wheel board and soft cover to ensure handy transport for rough road conditions, purchased separately as VT4888-ACC.



Specifications:

Line Array Element

Frequency Response (±3 dB):	60 Hz – 16 kHz
Frequency Range (-10 dB):	48 Hz – 18 kHz
Horizontal Coverage Angle (-6 dB):	90 deg. nominal (250 Hz – 16 kHz)
Vertical Coverage Angle (-6 dB):	Varies with array size and configuration
Maximum Peak Output:	136 dB to 146 dB, 1m frequency/bandpass dependent
Recommended Signal Processing:	dbx 480, BSS 366, XTA 226 supported

Transducer Sections

Low Frequency:	Two 2262H, 304 mm (12 in) dia., 76 mm (3 in) Dual Coil, Neodymium Differential Drive, Direct Cooled
Bandpass Nominal Impedance:	8 ohms each driver (each LF woofer individually wired)
Input Power Rating ¹ :	2000 W (8000 W peak) 2 hours 1400 W (5600 W peak) 100 hours
Bandpass Sensitivity:	98 dB, 1 W, @ 1m (3.3 ft)
Mid Frequency:	Four 2106HPL, 50 mm (2 in) dia. voice coil
Bandpass Nominal Impedance:	8 ohm (drivers wired series parallel)
Input Power Rating ¹ :	600 W (2400 W peak) 2 hours 400 W (1600 W peak) 100 hours
Bandpass Sensitivity:	102 dB, 1 W, @ 1m (3.3 ft)
High Frequency:	Two 2431H, 76 mm (3 in) aluminum diaphragm, 38 mm (1.5 in) throat diameter Neodymium drivers
Bandpass Nominal Impedance:	16 ohm (drivers wired in series)
Input Power Rating ¹ :	150 W (600 W peak)
Bandpass Sensitivity:	114 dB, 1 W, @ 1m (3.3 ft)

Enclosure

Box Construction:	Wedge frustum 5 degree side angle enclosure engineered wood composite structure, DuraFlex finish, 6 handles
Suspension System:	S.A.F.E. hardware, integral hinge bars nest in rigging tubes on box ends. Quick release pins with restraining lanyards
Grille:	Black perforated steel, foam backed
Input Connectors:	NL8, 2 each
Dimensions (H x W x D):	355.6 mm x 990.6 mm x 508 mm (14 in x 39 in x 20 in)
Net Weight:	49 kg (108 lb)
Shipping Weight:	59 kg (130 lb)

¹AES Standard, one decade pink noise with 6 dB crest factor within device's operational band, free air. Standard AES 2 hr rating plus long term 100 hr rating are specified for cone transducers.

JBL continually engages in research related to product improvement. Some materials, production methods and design refinements are introduced into existing products without notice as a routine expression of that philosophy. For this reason, any current JBL product may differ in some respect from its published description, but will always equal or exceed the original design specifications unless otherwise stated.



AM6340/95

High Power 3-Way Loudspeaker with 4 x 10" LF Drivers & Rotatable Horn

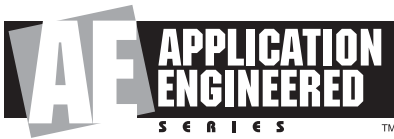

Key Features:

- ▶ 90° x 50° Coverage, rotatable for use in either vertical or horizontal orientation.
- ▶ Multiple LF Drivers extend pattern control into the LF Band.
- ▶ CMCD™ Cone Midrange Compression Driver™ provides low midrange distortion, increased sensitivity, extended bandwidth and improved phase coherency.
- ▶ PT™ Progressive Transition™ Waveguide for excellent pattern control with low distortion.
- ▶ Bi-Amp/Tri-Amp Switchable.
- ▶ Optional planar array frame kit (see AE Series Array Guide).

Applications:

- ▶ Performing arts facilities
- ▶ Theatrical sound design
- ▶ Auditoriums
- ▶ Houses of worship
- ▶ Live clubs
- ▶ Dance-clubs/discotheques
- ▶ Sports facilities
- ▶ Themed entertainment venues

AM6340/95 is a high power 3-way full-range loudspeaker system comprised of four 250 mm (10 in) LF drivers, one 200 mm (8 in) CMCD Cone Midrange Compression Driver, and one 38 mm (1.5 in) exit/75 mm (3 in) voice-coil HF compression driver. The multi-band PT Progressive Transition mid-high frequency waveguide provides well-controlled 90° by 50° coverage and is rotatable for cabinet positioning in either horizontal or vertical orientation. High-slope crossovers minimize band overlap and well-controlled off-axis response enhances arrayability.

The multiple LF driver design provides off-axis attenuation at the top end of the low frequency band. This model is ideal for use in conjunction with subwoofers for maximum pattern control in an exceptionally wide bandwidth system.

The cabinet is fitted with M10 threaded suspension points. Pre-engineered array bracketry is available.

AM6340/95 is part of JBL's AE Application Engineered Series, a versatile family of loudspeakers for a wide variety of fixed installation applications.



Specifications:

System:	
Frequency Range* (-10 dB):	50 Hz – 19 kHz
Frequency Response* (+3 dB):	55 Hz – 17 kHz
Coverage Pattern:	90° x 50°, rotatable waveguide
Directivity Factor (Q):	10
Directivity Index (DI):	10 dB
Crossover Modes:	Tri-amp/Bi-amp switchable
Passive Crossover Slopes:	MF/HF Section in Bi-amp mode: 4th order (24 dB/oct) Linkwitz-Riley HP & LP, 2.1 kHz
Transducer Power Rating (AES):	LF: 1200 W (4800 W peak), 2 hrs 1000 W (4000 W peak), 100 hrs MF: 350 W (1400 W peak), 100 hrs HF: 75 W (300 W peak), 2 hrs
Long-Term System Power Rating (IEC):	LF: 1000 W (4000 W peak), 100 hrs MF/HF: 350 W (1400 W peak), 100 hrs
Maximum SPL:	LF: 130 dB-SPL cont avg (136 dB peak) Tri-amp mode: MF: 133 dB-SPL cont avg (139 dB peak) HF: 132 dB-SPL cont avg (138 dB peak) Bi-amp mode: MF/HF: 132 dB-SPL cont avg (138 dB peak)
System Sensitivity of Passive Sections* (1W @ 1m):	MF/HF Section in Bi-amp mode: 108 dB SPL
Transducers:	
Low Frequency Driver:	4 x JBL 127H-4 250 mm (10 in) driver with 50 mm (2 in) voice coil
Nominal Impedance:	8 ohms
Sensitivity* (1W @ 1m, within operational band):	99 dB SPL
Midrange Driver:	JBL CMCD-81H Cone Midrange Compression Driver with integral 200 mm (8 in) diameter NDD™ Neodymium Differential Drive* dual voice-coil internal driver
Nominal Impedance:	8 ohms
Sensitivity* (1W @ 1m):	108 dB SPL
High Frequency Driver:	JBL 2431H, 38 mm (1.5 in) exit compression driver, 75 mm (3 in) voice coil
Nominal Impedance:	8 ohms
Sensitivity* (1W @ 1m):	113 dB SPL
Waveguide:	PT-K95MH
Physical:	
Enclosure:	Trapezoidal with 15 degree side angles, 16 mm (5/8 in) exterior grade 11-ply Finnish birch plywood
Suspension Attachment:	13 points (3 top, 3 bottom, 2 each side, 3 rear), M10 threaded hardware
Finish:	Black DuraFlex™ finish. White available upon request.
Grille:	Powder coated 14 gauge perforated steel, with acoustically transparent black foam backing.
Input Connector:	NLS Neutrik Speakon* and CE-compliant covered barrier strip terminals. Barrier terminals accept up to 5.2 sq mm (10 AWG) wire or max width 9 mm (.375 in) spade lugs. Speakon in parallel with barrier strip for loop-through.
Environmental Specifications:	Mil-Std 810, IP-x3 per IEC529.
Dimensions (H x W x D in vertical cabinet orientation):	1094 x 561 x 657 mm (43.1 x 22.1 x 25.9 in)
Net Weight:	57.2 kg (126 lb)
Optional Accessories:	M10 x 35 mm forged shoulder eyebolts with washers Optional planar array frame kit. See AE Series Bracket Guide

*Tri-amp mode, with recommended active tuning.

*Resultant engineered acoustical response of crossover network and components.

*AES standard, one decade pink noise with 6 dB crest factor within device's operational band, free air. Standard AES 2 hr rating plus long-term 100 hr rating are specified for low-frequency transducers.

*Passively crossed section rated with IEC standard, full bandwidth pink noise with 6 dB crest factor, 100 hours. Actively crossed section AES standard in cabinet, 100 hrs.

*Calculated based on power rating and sensitivity, exclusive of power compression.

*Anechoic sensitivity in free field, no additional sensitivity gain from boundary loading.

JBL continually engages in research related to product improvement. Changes introduced into existing products without notice are an expression of that philosophy.



AM6215/95 High Power 2-Way Loudspeaker with 1 x 15" LF & Rotatable Horn

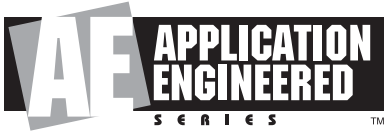

Key Features:

- ▶ 90° x 50° Coverage, rotatable for use in either vertical or horizontal orientation.
- ▶ Large PT™ Progressive Transition™ Waveguide for excellent pattern control with low distortion.
- ▶ Bi-Amp/Passive Switchable.
- ▶ Optional U-Bracket for easy installation (see AE Series Bracket Guide).

Applications:

- ▶ Performing arts facilities
- ▶ Theatrical sound design
- ▶ Auditoriums
- ▶ Houses of worship
- ▶ Live clubs
- ▶ Dance-clubs/discotheques
- ▶ Sports facilities
- ▶ Themed entertainment venues
- ▶ Delay/fill locations of larger systems

AM6215/95 is a high power 2-way full-range loudspeaker system comprised of one 380 mm (15 in) VGC™ Vented Gap Cooled low frequency driver and one 38 mm (1.5 in) exit/75 mm (3 in) voice-coil compression driver. The large PT Progressive Transition waveguide provides well-controlled 90° by 50° coverage and is rotatable for cabinet positioning in either horizontal or vertical orientation. High-slope crossovers minimize band overlap and well-controlled off-axis response enhances arrayability.

The cabinet is fitted with M10 threaded suspension points. Optional U-bracket is available for easy installation.

AM6215/95 is part of JBL's AE Application Engineered Series, a versatile family of loudspeakers for a wide variety of fixed installation applications.



Specifications:

System:	
Frequency Range ¹ (-10 dB):	35 Hz – 19 kHz
Frequency Response ¹ (±3 dB):	45 Hz – 17 kHz
Coverage Pattern:	90° x 50°, rotatable waveguide
Directivity Factor (Q):	12.6
Directivity Index (DI):	11 dB
Crossover Modes:	Bi-amp/Passive switchable
Passive Crossover Slopes ² :	4th order (24 dB/oct) Linkwitz-Riley HP & LP, 1.3 kHz
Transducer Power Rating (AES) ³ :	LF: 1000 W (4000 W peak), 2 hrs 600 W (2400 W peak), 100 hrs HF: 75 W (300 W peak), 2 hrs
Long-Term System Power Rating (IEC) ⁴ :	Passive mode: 600 W (2400 W peak), 100 hrs
Maximum SPL ⁵ :	Bi-amp mode: LF: 127 dB-SPL cont avg (133 dB peak) HF: 133 dB-SPL cont avg (139 dB peak) Passive mode: 127 dB-SPL cont avg (133 dB peak)
System Sensitivity ⁶ (1W @ 1m):	Passive mode: 97 dB SPL
Transducers:	
Low Frequency Driver:	1 x JBL 2226H 380 mm (15 in.) VGC™ driver with 100 mm (4 in) voice coil
Nominal Impedance:	8 ohms
Sensitivity ⁶ (1W @ 1m, within operational band):	97 dB SPL
High Frequency Driver:	JBL 2431H, 38 mm (1.5 in) exit compression driver, 75 mm (3 in) voice coil
Nominal Impedance:	8 ohms
Sensitivity ⁶ (1W @ 1m):	114 dB SPL
Waveguide:	PT-H95HF
Physical:	
Enclosure:	Trapezoidal with 15 degree side angles, 16 mm (5/8 in) exterior grade 11-ply Finnish birch plywood
Suspension Attachment:	15 points (4 top, 4 bottom, 2 each side, 3 rear), M10 threaded hardware
Finish:	Black DuraFlex™ finish. White available upon request.
Grille:	Powder coated 14 gauge perforated steel, with acoustically transparent black foam backing.
Input Connector:	NL4 Neutrik Speakon® and CE-compliant covered barrier strip terminals. Barrier terminals accept up to 5.2 sq mm (10 AWG) wire or max width 9 mm (.375 in) spade lugs. Speakon in parallel with barrier strip for loop-through.
Environmental Specifications:	Mil-Std 810; IP-x3 per IEC529.
Dimensions (H x W x D in vertical cabinet orientation):	783 x 422 x 504 mm (30.8 x 16.6 x 19.9 in)
Net Weight:	29.9 kg (66 lb)
Optional Accessories:	M10 x 35 mm forged shoulder eyebolts with washers U-Bracket MTU-1

¹Bi-amp mode, with recommended active tuning.

²Resultant engineered acoustical response of crossover network and components.

³AES standard, one decade pink noise with 6 dB crest factor within device's operational band, free air. Standard AES 2 hr rating plus long-term 100 hr rating are specified for low-frequency transducers.

⁴IEC standard, full bandwidth pink noise with 6 dB crest factor, 100 hours.

⁵Calculated based on power rating and sensitivity, exclusive of power compression.

⁶Anechoic sensitivity in free field, no additional sensitivity gain from boundary loading.

JBL continually engages in research related to product improvement. Changes introduced into existing products without notice are an expression of that philosophy.



AM4215/95 2-Way Loudspeaker with 1 x 15" LF & Rotatable Horn

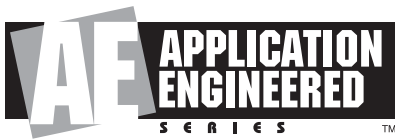

Key Features:

- ▶ 90° x 50° Coverage, rotatable for use in either vertical or horizontal orientation.
- ▶ Large PT™ Progressive Transition™ Waveguide for excellent pattern control with low distortion.
- ▶ Bi-Amp/Passive Switchable.
- ▶ Optional U-Bracket for easy installation (see AE Series Bracket Guide).

Applications:

- ▶ Small performing arts facilities
- ▶ Theatrical sound design
- ▶ Auditoriums
- ▶ Houses of worship
- ▶ Sports facilities
- ▶ Themed entertainment venues
- ▶ Delay/fill locations of larger systems

AM4215/95 is a medium power 2-way full-range loudspeaker system comprised of one 380 mm (15 in) low frequency driver and one 38 mm (1.5 in) exit/38 mm (1.5 in) voice-coil compression driver. The large PT Progressive Transition waveguide provides well-controlled 90° by 50° coverage and is rotatable for cabinet positioning in either horizontal or vertical orientation. High-slope crossovers minimize band overlap and well-controlled off-axis response enhances arrayability.

The cabinet is fitted with M10 threaded suspension points. Optional U-bracket is available for easy installation.

AM4215/95 is part of JBL's AE Application Engineered Series, a versatile family of loudspeakers for a wide variety of fixed installation applications.



Specifications:

System:	
Frequency Range ¹ (-10 dB):	40 Hz – 20 kHz
Frequency Response ¹ (±3 dB):	45 Hz – 18 kHz
Coverage Pattern:	90° x 50°, rotatable waveguide
Directivity Factor (Q):	12.6
Directivity Index (DI):	11 dB
Crossover Modes:	Bi-amp/Passive switchable
Passive Crossover Slopes ² :	4th order (24 dB/oct) Linkwitz-Riley HP & LP, 1.3 kHz
Transducer Power Rating (AES) ³ :	LF: 500 W (2000 W peak), 2 hrs 350 W (1400 W peak), 100 hrs HF: 35 W (140 W peak), 2 hrs
Long-Term System Power Rating (IEC) ⁴ :	Passive mode: 350 W (1400 W peak), 100 hrs
Maximum SPL:	Bi-amp mode: LF: 124 dB-SPL cont avg (130 dB peak) HF: 128 dB-SPL cont avg (134 dB peak) Passive mode: 124 dB-SPL cont avg (130 dB peak)
System Sensitivity ⁵ (1W @ 1m):	Passive mode: 97 dB SPL
Transducers:	
<u>Low Frequency Driver:</u>	1 x JBL 2033H 380 mm (15 in) driver with 75 mm (3 in) voice coil
Nominal Impedance:	8 ohms
Sensitivity ⁶ (1W @ 1m, within operational band):	97 dB SPL
<u>High Frequency Driver:</u>	JBL 2407H/MTA, 38 mm (1.5 in) exit compression driver, 38 mm (1.5 in) voice coil
Nominal Impedance:	8 ohms
Sensitivity (1W @ 1m):	113 dB SPL
<u>Waveguide:</u>	PT-H95HF
Physical:	
Enclosure:	Trapezoidal with 15 degree side angles, 16 mm (5/8 in) exterior grade 11-ply Finnish birch plywood
Suspension Attachment:	15 points (4 top, 4 bottom, 2 each side, 3 rear), M10 threaded hardware
Finish:	Black DuraFlex™ finish. White available upon request.
Grille:	Powder coated 14 gauge perforated steel, with acoustically transparent black foam backing.
Input Connector:	NL4 Neutrik Speakon® and CE-compliant covered barrier strip terminals. Barrier terminals accept up to 5.2 sq mm (10 AWG) wire or max width 9 mm (.375 in) spade lugs. Speakon in parallel with barrier strip for loop-through.
Environmental Specifications:	Mil-Std 810; IP-x3 per IEC529.
Dimensions (H x W x D in vertical cabinet orientation):	783 x 422 x 504 mm (30.8 x 16.6 x 19.9 in)
Net Weight:	29.0 kg (64 lb)
Optional Accessories:	M10 x 35 mm forged shoulder eyebolts with washers U-Bracket MTU-1

¹Bi-amp mode, with recommended active tuning.

²Resultant engineered acoustical response of crossover network and components.

³AES standard, one decade pink noise with 6 dB crest factor within device's operational band, free air. Standard AES 2 hr rating plus long-term 100 hr rating are specified for low-frequency transducers.

⁴IEC standard, full bandwidth pink noise with 6 dB crest factor, 100 hours.

⁵Calculated based on power rating and sensitivity, exclusive of power compression.

⁶Anechoic sensitivity in free field, no additional sensitivity gain from boundary loading.

JBL continually engages in research related to product improvement. Changes introduced into existing products without notice are an expression of that philosophy.



AM4212/00 2-Way Loudspeaker with 1 x 12" LF

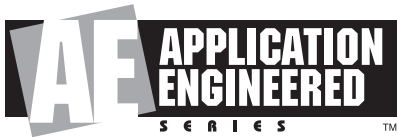

Key Features:

- ▶ 100° x 100° Coverage, usable in either vertical or horizontal orientation.
- ▶ Large PT™ Progressive Transition™ Waveguide for excellent pattern control with low distortion.
- ▶ Bi-Amp/Passive Switchable.
- ▶ Optional U-Bracket for easy installation.

Applications:

- ▶ Small performing arts facilities
- ▶ Houses of worship
- ▶ Theatrical sound design
- ▶ Auditoriums
- ▶ Sports facilities
- ▶ Themed entertainment venues

AM4212/00 is a medium power 2-way full-range loudspeaker system comprised of one 300 mm (12 in) low frequency driver and one 38 mm (1.5 in) exit/38 mm (1.5 in) voice-coil compression driver. The large PT Progressive Transition waveguide provides well-controlled wide 100° by 100° coverage in either horizontal or vertical orientation. High-slope crossovers minimize band overlap and well-controlled off-axis response enhances arrayability.

The cabinet is fitted with M10 threaded suspension points. Optional U-bracket is available for easy installation.

AM4212/00 is part of JBL's AE Application Engineered Series, a versatile family of loudspeakers for a wide variety of fixed installation applications.



Specifications:

System:	
Frequency Range ¹ (-10 dB):	55 Hz – 20 kHz
Frequency Response ² (±3 dB):	70 Hz – 18 kHz
Coverage Pattern:	100° x 100°
Directivity Factor (Q):	6.3
Directivity Index (DI):	8 dB
Crossover Modes:	Bi-amp/Passive switchable
Passive Crossover Slopes ³ :	4th order (24 dB/oct) Linkwitz-Riley HP & LP, 1.3 kHz
Transducer Power Rating (AES):	LF: 400 W (2000 W peak), 2 hrs 300 W (1200 W peak), 100 hrs HF: 35 W (140 W peak), 2 hrs
Long-Term System Power Rating (IEC):	Passive mode: 300 W (1200 W peak), 100 hrs
Maximum SPL ⁴ :	Bi-amp mode: LF: 120 dB-SPL cont avg (126 dB peak) HF: 125 dB-SPL cont avg (131 dB peak) Passive mode: 120 dB-SPL cont avg (126 dB peak)
System Sensitivity ⁵ (1W @ 1m):	Passive mode: 95 dB SPL
Transducers:	
Low Frequency Driver:	1 x JBL 2023H 300 mm (12 in) driver with 75 mm (3 in) voice coil
Nominal Impedance:	8 ohms
Sensitivity ⁶ (1W @ 1m, within operational band):	95 dB SPL
High Frequency Driver:	JBL 2407H/MTA, 38 mm (1.5 in) exit compression driver, 38 mm (1.5 in) voice coil
Nominal Impedance:	8 ohms
Sensitivity (1W @ 1m):	110 dB SPL
Waveguide:	PT-H95HF
Physical:	
Enclosure:	Trapezoidal with 15 degree side angles, 16 mm (5/8 in) exterior grade 11-ply Finnish birch plywood
Suspension Attachment:	15 points (4 top, 4 bottom, 2 each side, 3 rear), M10 threaded hardware
Finish:	Black DuraFlex™ finish. White available upon request.
Grille:	Powder coated 14 gauge perforated steel, with acoustically transparent black foam backing.
Input Connector:	NL4 Neutrik Speakon® and CE-compliant covered barrier strip terminals. Barrier terminals accept up to 5.2 sq mm (10 AWG) wire or max width 9 mm (.375 in) spade lugs. Speakon in parallel with barrier strip for loop-through.
Environmental Specifications:	Mil-Std 810; IP-x3 per IEC529.
Dimensions (H x W x D in vertical cabinet orientation):	713 x 371 x 460 mm (28.1 x 14.6 x 18.1 in)
Net Weight:	25.4 kg (56 lb)
Optional Accessories:	M10 x 35 mm forged shoulder eyebolts with washers U-Bracket MTU-3

¹Bi-amp mode, with recommended active tuning.

²Resultant engineered acoustical response of crossover network and components.

³AES standard, one decade pink noise with 6 dB crest factor within device's operational band, free air. Standard AES 2 hr rating plus long-term 100 hr rating are specified for low-frequency transducers.

⁴IEC standard, full bandwidth pink noise with 6 dB crest factor, 100 hours.

⁵Calculated based on power rating and sensitivity, exclusive of power compression.

⁶Anechoic sensitivity in free field, no additional sensitivity gain from boundary loading.

JBL continually engages in research related to product improvement. Changes introduced into existing products without notice are an expression of that philosophy.



AC2215/00 Compact 2-Way Loudspeaker with 1 x 15" LF

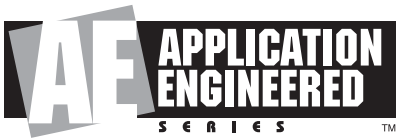

Key Features:

- ▶ 100° x 100° Coverage.
- ▶ PT™ Progressive Transition™ Waveguide for good pattern control with low distortion.
- ▶ Bi-Amp/Passive Switchable.
- ▶ Optional U-Bracket for easy installation (see AE Series Bracket Guide).

Applications:

- ▶ Small performing arts facilities
- ▶ Houses of worship
- ▶ Theatrical sound design
- ▶ Auditoriums
- ▶ Sports facilities
- ▶ Themed entertainment venues

AC2215/00 is a compact 2-way full-range loudspeaker system comprised of one 380 mm (15 in) low frequency driver and one 38 mm (1.5 in) exit/44 mm (1.75 in) voice-coil compression driver. The PT Progressive Transition waveguide provides wide 100° by 100° coverage. High-slope passive crossovers minimize band overlap.

The cabinet is fitted with M10 threaded suspension points. Optional U-bracket is available for easy installation.

AC2215/00 is part of JBL's AE Application Engineered Series, a versatile family of loudspeakers for a wide variety of fixed installation applications.



Specifications:

System:	
Frequency Range ¹ (-10 dB):	42 Hz – 19 kHz
Frequency Response ¹ (±3 dB):	50 Hz – 17 kHz
Coverage Pattern:	100° x 100°
Directivity Factor (Q):	7.1
Directivity Index (DI):	8.5 dB
Crossover Modes:	Bi-amp/Passive switchable
Passive Crossover Slopes:	4th order (24 dB/oct) Butterworth HP & LP, 1300 Hz
Transducer Power Rating (AES) ² :	LF: 275 W (1100 W peak), 2 hrs 250 W (1000 W peak), 100 hrs HF: 50 W (200 W peak), 2 hrs
Long-Term System Power Rating (IEC) ³ :	Passive mode: 250 W (1000 W peak), 100 hrs
Maximum SPL ⁴ :	Bi-amp mode: LF: 121 dB-SPL cont avg (127 dB peak) HF: 126 dB-SPL cont avg (132 dB peak) Passive mode: 121 dB-SPL cont avg (127 dB peak)
System Sensitivity ⁵ (1W @ 1m):	Passive mode: 97 dB SPL
Transducers:	
Low Frequency Driver:	1 x JBL M115-8A 380 mm (15 in) driver with 63 mm (2.5 in) voice coil
Nominal Impedance:	8 ohms
Sensitivity ⁶ (1W @ 1m, within operational band):	97 dB SPL
High Frequency Driver:	JBL 2418H-1/MTA, 44 mm (1.75 in) voice coil
Nominal Impedance:	8 ohms
Sensitivity (1W @ 1m):	109 dB SPL
Waveguide:	PT-F1010HF
Physical:	
Enclosure:	Trapezoidal with 15 degree side angles, 16 mm (5/8 in) exterior grade 11-ply Finnish birch plywood
Suspension Attachment:	15 points (4 top, 4 bottom, 2 each side, 3 rear), M10 threaded hardware
Finish:	Black DuraFlex™ finish. White available upon request.
Grille:	Powder coated 14 gauge perforated steel, with acoustically transparent black foam backing.
Input Connector:	NL4 Neutrik Speakon® and CE-compliant covered barrier strip terminals. Barrier terminals accept up to 5.2 sq mm (10 AWG) wire or max width 9 mm (.375 in) spade lugs. Speakon in parallel with barrier strip for loop-through.
Environmental Specifications:	Mil-Std 810; IP-x3 per IEC529.
Dimensions (H x W x D):	637 x 422 x 504 mm (25.1 x 16.6 x 19.9 in)
Net Weight:	25.0 kg (55 lb)
Optional Accessories:	M10 x 35 mm forged shoulder eyebolts with washers U-Bracket MTU-2

¹Bi-amp mode, with recommended active tuning.

²Resultant engineered acoustical response of crossover network and components.

³AES standard, one decade pink noise with 6 dB crest factor within device's operational band, free air. Standard AES 2 hr rating plus long-term 100 hr rating are specified for low-frequency transducers.

⁴IEC standard, full bandwidth pink noise with 6 dB crest factor, 100 hours.

⁵Calculated based on power rating and sensitivity, exclusive of power compression.

⁶Anechoic sensitivity in free field, no additional sensitivity gain from boundary loading.

JBL continually engages in research related to product improvement. Changes introduced into existing products without notice are an expression of that philosophy.



AC2212/00 Compact 2-Way Loudspeaker with 1 x 12" LF

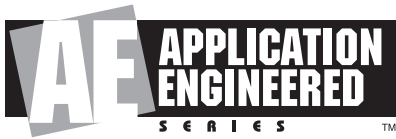

Key Features:

- ▶ 100° x 100° Coverage.
- ▶ PT™ Progressive Transition™ Waveguide for good pattern control with low distortion.
- ▶ Bi-Amp/Passive Switchable.
- ▶ Optional U-Bracket for easy installation.
- ▶ Optional planar array frame kit (see AE Series Array Guide).

Applications:

- ▶ Lecture halls
- ▶ Houses of worship
- ▶ Corporate learning centers
- ▶ Small performing arts facilities
- ▶ Theatrical sound design
- ▶ Auditoriums
- ▶ Sports facilities
- ▶ Themed entertainment venues

AC2212/00 is a compact 2-way full-range loudspeaker system comprised of one 300 mm (12 in) low frequency driver and one 38 mm (1.5 in) exit/44 mm (1.75 in) voice-coil compression driver. The PT Progressive Transition waveguide provides wide 100° by 100° coverage. High-slope passive crossovers minimize band overlap.

The cabinet is fitted with M10 threaded suspension points. Optional U-bracket, as well as pre-engineered array bracketry is available for easy installation. Four threaded inserts located on back of the enclosure allow attachment of an Omnimount™ or similar mounting bracket.

AC2212/00 is part of JBL's AE Application Engineered Series, a versatile family of loudspeakers for a wide variety of fixed installation applications.



Specifications:

System:	
Frequency Range ¹ (-10 dB):	50 Hz – 19 kHz
Frequency Response ¹ (±3 dB):	55 Hz – 17 kHz
Coverage Pattern:	100° x 100°
Directivity Factor (Q):	7.1
Directivity Index (DI):	8.5 dB
Crossover Modes:	Bi-amp/Passive switchable
Passive Crossover Slopes ² :	4th order (24 dB/oct) Transitional HP & LP, 1.3 kHz
Transducer Power Rating (AES) ³ :	LF: 300 W (1100 W peak), 2 hrs 250 W (1000 W peak), 100 hrs HF: 50 W (200 W peak), 2 hrs
Long-Term System Power Rating (IEC) ⁴ :	Passive mode: 250 W (1000 W peak), 100 hrs
Maximum SPL ⁵ :	Bi-amp mode: LF: 120 dB-SPL cont avg (126 dB peak) HF: 126 dB-SPL cont avg (132 dB peak) Passive mode: 120 dB-SPL cont avg (126 dB peak)
System Sensitivity ⁶ (1W @ 1m):	Passive mode: 95 dB SPL
Transducers:	
Low Frequency Driver:	1 x JBL M112-8 300 mm (12 in) driver with 63 mm (2.5 in) voice coil
Nominal Impedance:	8 ohms
Sensitivity ⁶ (1W @ 1m, within operational band):	95 dB SPL
High Frequency Driver:	JBL 2418H-1/MTA, 38 mm (1.5 in) exit compression driver, 44 mm (1.75 in) voice coil
Nominal Impedance:	8 ohms
Sensitivity (1W @ 1m):	109 dB SPL
Waveguide:	PT-F1010HF
Physical:	
Enclosure:	Trapezoidal with 15 degree side angles, 16 mm (5/8 in) exterior grade 11-ply Finnish birch plywood
Suspension Attachment:	15 points (4 top, 4 bottom, 2 each side, 3 rear), M10 threaded hardware. 4 x M6 on rear for Omnimount™ 100 Series
Finish:	Black DuraFlex™ finish. White available upon request.
Grille:	Powder coated 14 gauge perforated steel, with acoustically transparent black foam backing.
Input Connector:	NL4 Neutrik Speakon® and CE-compliant covered barrier strip terminals. Barrier terminals accept up to 5.2 sq mm (10 AWG) wire or max width 9 mm (.375 in) spade lugs. Speakon in parallel with barrier strip for loop-through.
Environmental Specifications:	Mil-Std 810; IP-x3 per IEC529.
Dimensions (H x W x D):	548 x 355 x 352 mm (21.6 x 14.0 x 13.9 in)
Net Weight:	19.1 kg (42 lb)
Optional Accessories:	M10 x 35 mm forged shoulder eyebolts with washers U-Bracket MTU-4 Optional planar array frame kit. See AE Series Bracket Guide

¹Bi-amp mode, with recommended active tuning.

²Resultant engineered acoustical response of crossover network and components.

³AES standard, one decade pink noise with 6 dB crest factor within device's operational band, free air. Standard AES 2 hr rating plus long-term 100 hr rating are specified for low-frequency transducers.

⁴IEC standard, full bandwidth pink noise with 6 dB crest factor, 100 hours.

⁵Calculated based on power rating and sensitivity, exclusive of power compression.

⁶Anechoic sensitivity in free field, no additional sensitivity gain from boundary loading.

JBL continually engages in research related to product improvement. Changes introduced into existing products without notice are an expression of that philosophy.



ASH6118 Maximum Impact Horn-Loaded Subwoofer

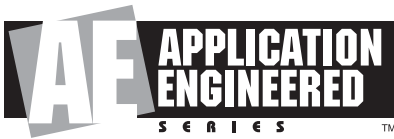

Key Features:

- ▶ 1 x 18" 2242H SVG™ Driver.
- ▶ Designed to be used singly or in multiples (2 minimum, 4 optimum) with proximity placement or with proper boundary surface loading.
- ▶ Maximum low frequency output & sensitivity.
- ▶ Excellent "punch" with true sub-bass extension.

Applications:

- ▶ Performing arts facilities
- ▶ Theatrical sound design
- ▶ Auditoriums
- ▶ Houses of worship
- ▶ Live clubs
- ▶ Dance-clubs/discotheques
- ▶ Sport facilities
- ▶ Themed entertainment venues

ASH6118 is a high power horn-loaded subwoofer system comprised of one 460 mm (18 in) SVG Super Vented Gap low frequency driver. The slow-expansion internal folded horn provides maximum sensitivity, output level and subwoofer impact.

ASH6118 is part of JBL's AE Application Engineered Series, a versatile family of loudspeakers for a wide variety of applications.



Specifications:

System:	
Frequency Range (-10 dB):	1 cabinet: 25 Hz – 250 Hz 2 cabinets: 24 Hz – 250 Hz 4 cabinets: 22 Hz – 250 Hz
Frequency Response (±3 dB):	1 cabinet: 30 Hz – 200 Hz 2 cabinets: 28 Hz – 200 Hz 4 cabinets: 26 Hz – 200 Hz
Transducer Power Rating (AES): ¹	1 cabinet: 1200 W (4800 W peak), 2 hrs, 800 W (3200 W peak), 100 hrs 2 cabinets: 2400 W (9600 W peak), 2 hrs, 1600 W (6400 W peak), 100 hrs 4 cabinets: 4800 W (19200 W peak), 2 hrs, 3200 W (12800 W peak), 100 hrs
Long-Term System Power Rating: ²	1 cabinet: 800 W (3200 W peak), 100 hrs 2 cabinets: 1600 W (6400 W peak), 100 hrs 4 cabinets: 3200 W (12800 W peak), 100 hrs
Maximum SPL: ³	30 Hz – 140 Hz: 1 cabinet: 133 dB-SPL cont avg (139 dB peak) 2 cabinets: 138 dB-SPL cont avg (144 dB peak) 4 cabinets: 144 dB-SPL cont avg (150 dB peak)
System Sensitivity (dB-SPL, 1W @ 1m): ⁴	30 Hz – 150 Hz: 1 cabinet: 102 dB 2 cabinets: 104 dB 4 cabinets: 107 dB
Nominal Impedance:	8 ohms per cabinet
Transducers:	
Low Frequency Driver:	Per cabinet: 1 x JBL 2242H 460 mm (18 in) SVG™ driver with 100 mm (4 in) voice coil
Physical:	
Enclosure:	Rectangular cabinet, 18 mm (3/4 in) exterior grade 13-ply birch plywood
Suspension Attachment:	None
Finish:	Black DuraFlex™ finish. White available upon request.
Input Connector:	NL4 Neutrik Speakon® and CE-compliant covered barrier strip terminals. Barrier terminals accept up to 5.2 sq mm (10 AWG) wire or max width 9 mm (.375 in) spade lugs. Speakon in parallel with barrier strip for loop-through.
Environmental Specifications:	Mil-Std 810; IP-x3 per IEC529.
Dimensions (H x W x D in horizontal cabinet orientation):	564 x 1530 x 1288 mm (22.3 x 56.4 x 50.7 in)
Net Weight:	159.3 kg (351 lb)

¹AES standard, one decade pink noise with 6 dB crest factor within device's operational band, free air. Standard AES 2 hr rating plus long-term 100 hr rating are specified for low-frequency transducers.

²AES standard, one decade pink noise with 6 dB crest factor, in cabinet, long-term 100 hr rating.

³Calculated based on power rating and sensitivity, exclusive of power compression.

⁴Half-space (2 π) loading, averaged in specified frequency band.

JBL continually engages in research related to product improvement. Changes introduced into existing products without notice are an expression of that philosophy.



ASB6128V

Extended Response, High Output,
Dual 18" Subwoofer

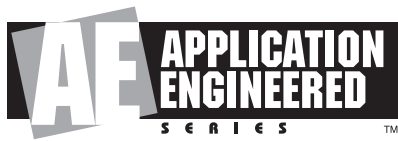

Key Features:

- ▶ 2 x 18" 2258H NDD™ Neodymium Differential Drive® drives in a folded baffle "V"-configuration.
- ▶ Driver motor structures outward for maximum cooling.
- ▶ Large vent area for high output with low distortion.
- ▶ Parallel/Discrete Switchable.
- ▶ Arrays with certain AE Series full-range models (see AE Series Array Guide).

Applications

- ▶ Performing arts facilities
- ▶ Theatrical sound design
- ▶ Auditoriums
- ▶ Houses of worship
- ▶ Live clubs
- ▶ Dance-clubs/discotheques
- ▶ Sports facilities
- ▶ Themed entertainment venues

ASB6128V is a high power subwoofer system comprised of two 460 mm (18 in) NDD Neodymium Differential Drive low frequency drivers in "V"-loaded configuration. The compact cabinet provides a common height with some of the AE Series full-range loud-speaker models, for easy arrayability of multiple cabinets with the subwoofer in the center. The "V"-loaded baffle provides additional sensitivity in the deep-bass region as well as tighter clustering of drivers for better mutual coupling in arrays. A deep cabinet design allows sufficient internal volume for extended low frequency bandwidth with minimum frontal profile. The rectangular cabinet is fitted with M10 threaded suspension points. Pre-engineered array bracketry is available.

ASB6128V is part of JBL's AE Application Engineered Series, a versatile family of loudspeakers for a wide variety of applications.



Specifications:

System:	
Frequency Range (-10 dB):	22 Hz – 300 Hz
Frequency Response (±3 dB):	25 Hz – 300 Hz
Input Modes:	Drivers Parallel / Drivers Discrete
Transducer Power Rating (AES) ¹ :	2400 W (9600 W peak), 2 hrs
Long-Term System Power Rating ² :	1600 W (6400 W peak), 100 hrs
Maximum SPL ³ :	30 Hz – 100 Hz: 132 dB-SPL cont avg (138 dB peak) 100 Hz – 300 Hz: 136 dB-SPL cont avg (142 peak)
System Sensitivity (dB-SPL, 1W @ 1m) ⁴ :	25 Hz – 80 Hz: 98 dB 80 Hz – 200 Hz: 102 dB
Nominal Impedance:	4 ohms in parallel-drive mode 2 x 8 ohms in discrete-drive mode
Transducers:	
Low Frequency Driver:	2 x JBL 2258H 460 mm (18 in) NDD Neodymium Differential Drive transducers with dual 75 mm (3 in) voice coil
Physical:	
Enclosure:	Rectangular cabinet, 16 mm (5/8 in) exterior grade 11-ply Finnish birch plywood
Suspension Attachment:	13 points (3 top, 3 bottom, 2 each side, 3 rear), M10 threaded hardware
Finish:	Black DuraFlex™ finish. White available upon request.
Grille:	Powder coated 14 gauge perforated steel, with acoustically transparent black foam backing.
Input Connector:	NL4 Neutrik Speakon® and CE-compliant covered barrier strip terminals. Barrier terminals accept up to 5.2 sq mm (10 AWG) wire or max width 9 mm (.375 in) spade lugs. Speakon in parallel with barrier strip for loop-through.
Environmental Specifications:	Mil-Std 810; IP-x3 per IEC529.
Dimensions (H x W x D in vertical cabinet orientation):	967 x 561 x 1215 mm (38.1 x 22.1 x 47.85 in)
Net Weight:	89.8 kg (198 lb)
Optional Accessories:	M10 x 35 mm forged shoulder eyebolts with washers Optional planar array frame kit. See AE Series Bracket Guide

¹AES standard, one decade pink noise with 6 dB crest factor within device's operational band, free air, standard AES 2 hr rating plus long-term 100 hr rating.

²AES standard, one decade pink noise with 6 dB crest factor, in cabinet, long-term 100 hr rating.

³Calculated based on power rating and sensitivity, exclusive of power compression.

⁴Half-space (2π) loading, averaged in specified frequency band.

JBL continually engages in research related to product improvement. Changes introduced into existing products without notice are an expression of that philosophy.



ASB6128 High Power Dual 18" Subwoofer

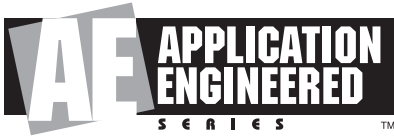

Key Features:

- ▶ 2 x 18" 2242H SVG™ Driver.
- ▶ Large vent area for high output with low distortion.
- ▶ Parallel/Discrete Switchable input mode.
- ▶ Arrays with various AE Series models (see AE Series Array Guide).

Applications:

- ▶ Performing arts facilities
- ▶ Theatrical sound design
- ▶ Auditoriums
- ▶ Houses of worship
- ▶ Live clubs
- ▶ Dance-clubs/discotheques
- ▶ Sport facilities
- ▶ Themed entertainment venues

ASB6128 is a high power subwoofer system comprised of two 460 mm (18 in) SVG Super Vented Gap low frequency drivers in a front-loaded, vented configuration. The deep cabinet allows for extended low frequency bandwidth with minimum frontal profile. The rectangular cabinet is fitted with M10 threaded suspension points. Pre-engineered array bracketry is available.

ASB6128 is part of JBL's AE Application Engineered Series, a versatile family of loudspeakers for a wide variety of applications.



Specifications:

System:	
Frequency Range (-10 dB):	28 Hz – 1 kHz
Frequency Response (±3 dB):	35 Hz – 1 kHz
Input Modes:	Drivers Parallel / Drivers Discrete
Transducer Power Rating (AES) ¹ :	2400 W (9600 W peak), 2 hrs
Long-Term System Power Rating ² :	1600 W (6400 W peak), 100 hrs
Maximum SPL ³ :	30 Hz – 100 Hz: 136 dB-SPL cont avg (142 dB peak) 100 Hz – 500 Hz: 136 dB-SPL cont avg (142 dB peak)
System Sensitivity (dB-SPL, 1W @ 1m) ⁴ :	30 Hz – 100 Hz: 102 dB 100 Hz – 500 Hz: 102 dB
Nominal Impedance:	4 ohms in parallel-drive mode 2 x 8 ohms in discrete-drive mode
Transducers:	
Low Frequency Driver:	2 x JBL 2242H 460 mm (18 in) SVG™ drivers with 100 mm (4 in) voice coil
Physical:	
Enclosure:	Rectangular cabinet, 16 mm (5/8 in) exterior grade 11-ply Finnish birch plywood
Suspension Attachment:	12 points (3 top, 3 bottom, 2 each side, 2 rear), M10 threaded hardware
Finish:	Black DuraFlex™ finish. White available upon request.
Grille:	Powder coated 14 gauge perforated steel, with acoustically transparent black foam backing.
Input Connector:	NL4 Neutrik Speakon® and CE-compliant covered barrier strip terminals. Barrier terminals accept up to 5.2 sq mm (10 AWG) wire or max width 9 mm (.375 in) spade lugs. Speakon in parallel with barrier strip for loop-through.
Environmental Specifications:	Mil-Std 810; IP-x3 per IEC529.
Dimensions (H x W x D in vertical cabinet orientation):	1094 x 561 x 816 mm (43.1 x 22.1 x 32.2 in)
Net Weight:	73.0 kg (161 lb)
Optional Accessories:	M10 x 35 mm forged shoulder eyebolts with washers. Optional planar array frame kit. See AE Series Bracket Guide

¹AES standard, one decade pink noise with 6 dB crest factor within device's operational band, free air. Standard AES 2 hr rating plus long-term 100 hr rating are specified for low-frequency transducers.

²AES standard, one decade pink noise with 6 dB crest factor, in cabinet, long-term 100 hr rating.

³Calculated based on power rating and sensitivity, exclusive of power compression.

⁴Half-space (2 π) loading, averaged in specified frequency band.

JBL continually engages in research related to product improvement. Changes introduced into existing products without notice are an expression of that philosophy.



AL6125 High Power Dual 15" Low Frequency Loudspeaker

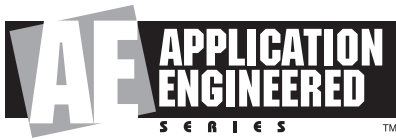

Key Features:

- ▶ 2 x 15" 2226H VGC™ Driver.
- ▶ Large vent area for high output with low distortion.
- ▶ Parallel/Discrete Switchable input mode.

Applications:

- ▶ Performing arts facilities
- ▶ Theatrical sound design
- ▶ Auditoriums
- ▶ Houses of worship
- ▶ Live clubs
- ▶ Dance-clubs/discotheques
- ▶ Sports facilities
- ▶ Themed entertainment venues

AL6125 is a high power, low frequency loudspeaker system comprised of two 380 mm (15 in) VGC Vented Gap Cooled low frequency drivers in a front-loaded, vented configuration. The rectangular cabinet is fitted with M10 threaded suspension points.

AL6125 is part of JBL's AE Application Engineered Series, a versatile family of loudspeakers for a wide variety of applications.



Specifications:

System:	
Frequency Range (-10 dB):	40 Hz – 2.5 kHz
Frequency Response (±3 dB):	42 Hz – 2.1 kHz
Input Modes:	Drivers Parallel / Drivers Discrete
Transducer Power Rating (AES):	2000 W (8000 W peak), 2 hrs
Long-Term System Power Rating:	1200 W (4800 W peak), 100 hrs
Maximum SPL:	50 Hz – 125 Hz: 130 dB-SPL cont avg (136 dB peak) 125 Hz – 800 Hz: 129 dB-SPL cont avg (135 dB peak)
System Sensitivity (dB-SPL, 1W @ 1m):	50 Hz – 125 Hz: 103 dB 125 Hz – 800 Hz: 102 dB
Nominal Impedance:	4 ohms in parallel-drive mode 2 x 8 ohms in discrete drive mode
Transducers:	
Low Frequency Driver:	2 x JBL 2226H 380 mm (15 in) VGC™ drivers with 100 mm (4 in) voice coil
Physical:	
Enclosure:	Rectangular cabinet, 16 mm (5/8 in) exterior grade 11-ply Finnish birch plywood
Suspension Attachment:	12 points (3 top, 3 bottom, 2 each side, 2 rear), M10 threaded hardware
Finish:	Black DuraFlex™ finish. White available upon request.
Grille:	Powder coated 14 gauge perforated steel, with acoustically transparent black foam backing.
Input Connector:	NL4 Neutrik Speakon® and CE-compliant covered barrier strip terminals. Barrier terminals accept up to 5.2 sq mm (10 AWG) wire or max width 9 mm (.375 in) spade lugs. Speakon in parallel with barrier strip for loop-through.
Environmental Specifications:	Mil-Std 810; IP-x3 per IEC529.
Dimensions (H x W x D in vertical cabinet orientation):	967 x 422 x 504 mm (38.1 x 16.6 x 19.9 in)
Net Weight:	44.5 kg (98 lb)
Optional Accessories:	M10 x 35 mm forged shoulder eyebolts with washers.

¹AES standard, one decade pink noise with 6 dB crest factor within device's operational band, free air. Standard AES 2 hr rating plus long-term 100 hr rating are specified for low-frequency transducers.

²AES standard, one decade pink noise with 6 dB crest factor, in cabinet, long-term 100 hr rating.

³Calculated based on power rating and sensitivity, exclusive of power compression.

⁴Half-space (2π) loading, averaged in specified frequency band.

JBL continually engages in research related to product improvement. Changes introduced into existing products without notice are an expression of that philosophy.



CBT4

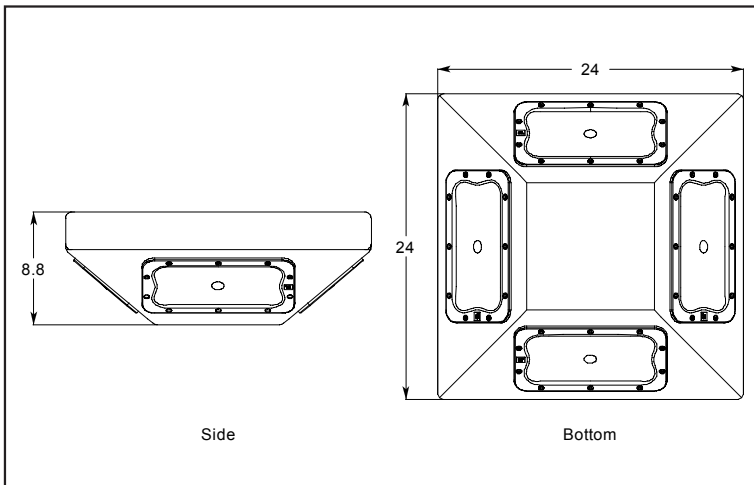

Dedicated Dance Club Design

Ultra-High Frequency Array

360 Degree Coverage

Key Features:

- ▶ PT (Progressive Transition™) High Frequency Waveguide Design
- ▶ Four 2407H Neodymium magnet, 1.75" diaphragm ring-radiator compression drivers
- ▶ Unique enclosure geometry allows coverage of the entire dance floor from a single point

Specifications:

System:

Frequency Range (-10 dB):	2 kHz - 23 kHz
Frequency Response (±3 dB):	2.7 kHz - 20 kHz
Horizontal Coverage Angle (-6 dB):	360°
Vertical Coverage Angle (-6 dB):	50°

Transducers:

High Frequency:	4x 2407H; 44.5 mm (1.75 in) diaphragm and voicecoil, 25 mm (1 in) throat
Nominal Impedance:	8 Ohms
Input Power Rating:	200 Watts AES; 800 W Peak
Sensitivity:	113 dB, 1 W @ 1 m (3.3 ft)
Calculated Maximum SPL:	142 dB @ 1 m (3.3 ft)

Physical:

Enclosure:	16mm (5/8") Finnish birch plywood; truncated pyramidal shape
Suspension Attachment:	4 points - located on top of enclosure; M10 thread pattern
Finish:	Black DuraFlex coating (white optional)
Grille:	None
Input Connector:	Barrier strip & Neutrik NL4 Speakon; located on top of enclosure
Dimensions (H x W x D):	224 mm x 610 mm x 610 mm (8.8 in x 24 in x 24 in)
Net Weight:	18.2 kg (40 lb)

The CBT4 is a premier member of JBL's purpose-designed dance club family of products. Designed with a specific mission in mind: cover the entire dance floor with smooth, clean and extended high frequency energy from one central overhead position.

The CBT4 improves upon the performance of traditional "bullet tweeter" arrays through the use of a true compression driver, the 2407H, and JBL's latest generation PT waveguides. The leading edge design of the 2407H, incorporating a rare earth Neodymium magnet structure and a center-clamped titanium diaphragm offers more high frequency output than pre-existing designs plus lower distortion and higher power handling. The broad, smooth coverage pattern of the PT waveguides serves to spread all of these extreme highs evenly about the room.

CBT4 is intended to be suspended overhead. The compact, low profile pyramidal enclosure allows for sufficient headroom even in low-ceiling applications.

CBT4 requires the use of an active crossover. BSS Soundweb, dbx Driverack or similar digital controller are required for optimum performance.

The CBT4 is built when ordered. Contact your local sales representative for information on lead time.

¹ Anechoic sensitivity, within normal bandpass of system or section of system, in free field; does not assume any additional sensitivity gain from boundary loading.

JBL continually engages in research related to product improvement. Some materials, production methods and design refinements are introduced into existing products without notice as a routine expression of that philosophy. For this reason, any current JBL product may differ in some respect from its published description, but will always equal or exceed the original design specifications unless otherwise stated. 4/30/03 ATR



EON10 G2 Portable Powered Speaker System



Application:

Live sound reinforcement, speech, vocals, and music playback in entertainment, A/V, and institutional venues – especially when ease of use, audio quality and portability are important factors.

Amplification, mixing, and monitoring for electronic and electro-acoustic instruments.

Key Features:

- ▶ The second generation of one of the most successful and influential professional speaker systems ever.
- ▶ 10" Differential Drive® low frequency driver with neodymium magnet for light weight and reduced distortion.
- ▶ 1" JBL compression driver with titanium diaphragm and ferro-fluid cooling.
- ▶ 125 watt low-frequency and 50 watt high-frequency (bi-amplified) amplifiers – Actual power delivered to the drivers.
- ▶ Three inputs. One balanced, mic/line selectable input and one dual-channel, 1/4" TRS phone line-level input.
- ▶ Balanced loop/mix output. "Daisy-chain" additional EON speakers or send the mixed output to a mixing console.
- ▶ 60° x 90° (nominal) constant directivity horn.
- ▶ Thermomaster® Total Thermal Management System®. A single piece, cast-aluminum baffle integrates the woofer frame, horn, and amplifier heat sink. Air movement in the finned ports dissipates heat – no internal or external cooling fans are required.
- ▶ Rugged, lightweight, black co-polymer enclosure.
- ▶ Integral 35 mm pole mount receptacle with securing thumb screw.
- ▶ Multi-angle enclosure for front of house or stage monitor application.
- ▶ For more low-frequency power and performance, add the EONSUB G2.



Specifications

Freq. Range (-10 dB):	65 Hz - 18 kHz
Freq. Response (± 3 dB):	90 Hz - 16 kHz
Horz. Coverage (-6 dB):	90° Nominal
Vert. Coverage (-6 dB):	60° Nominal
Rated Maximum SPL:	117 dB, @ 1 m (3.3 ft)
Dimensions (H x W x D):	493 mm x 356 mm x 307 mm (19.4 in x 14.0 in x 12.1 in.)
Net Weight:	10.4 kg (23 lb)
LF Driver:	Integral frame with one 10" (254 mm) driver, neodymium magnet, 1.5" Differential Drive voice coil.
HF Driver:	JBL 2412 1" compression driver, titanium diaphragm, ferro-fluid cooled.
Amplifier Power LF:	125 watts @ low-frequency driver impedance.
Amplifier Power HF:	50 watts @ high-frequency driver impedance.
Input 1 Sensitivity:	-48 dBu to 0 dBu for rated output (Mic/Line switch in MIC position) -6 dBu to +20 dBu for rated output (Mic/Line switch in LINE position)
Input 2 & 3 Sensitivity:	-12 dBu to +20 dBu for rated output
Output Level:	+26 dBu (max), Loop/Mix switch in MIX position
Crossover Frequency:	2.7 kHz
Loop/Mix Out:	XLR/M, balanced
AC Input:	110-230 VAC, 50-60 Hz, 110 watts rating per UL, detachable IEC power cable.



EON15 G2 **Powered Speaker System**



Application:

Live sound reinforcement, speech, vocals, and music playback in entertainment, A/V, and institutional venues - especially when ease of use, audio quality and portability are important factors.

Amplification, mixing, and monitoring for electronic musical instruments.

Key Features:

- ▶ The second generation of one of the most successful and influential professional speaker systems ever.
- ▶ 15" Differential Drive® low-frequency driver with dual neodymium magnet for light weight and reduced distortion.
- ▶ 1" (throat diameter) JBL compression driver with 1.75" titanium diaphragm and ferro-fluid cooling.
- ▶ 300 watts low-frequency and 100 watts high-frequency (bi-amplified) - actual power delivered to the drivers.
- ▶ Built in 3-input mixer. One balanced mic/line input, two 1/4" phone line-level inputs. Two-band equalization.
- ▶ Balanced loop-through/mix output. "Daisy-chain" additional EON speakers or send the mixed output to a mixing console.
- ▶ 60° x 90° (nominal) constant directivity horn.
- ▶ Thermomaster® Total Thermal Management System®. A single piece, cast-aluminum baffle integrates the woofer frame, horn, and amplifier heat sink. Air movement in the finned ports dissipates heat - no internal or external cooling fans are required.
- ▶ Rugged, light-weight, black co-polymer enclosure.
- ▶ Integral 35 mm pole mount receptacle.
- ▶ Multi-angle enclosure for front of house or stage monitor application.
- ▶ Tailored dynamic processing protects amplifiers and speakers from being over-driven without producing extreme changes in frequency response as level varies.
- ▶ Extended low-frequency performance Delivers powerful bass down to 39 Hz.



Preliminary Specifications:

Freq. Range (-10 dB):	39 Hz - 18 kHz
Freq. Response (±3 dB):	42 Hz - 17 kHz
Horz. Coverage (-6 dB):	90° Nominal
Vert. Coverage (-6 dB):	60° Nominal
Rated Maximum SPL:	129 dB, @ 1 m (3.3 ft)
Dimensions (H x W x D):	686 mm x 430 mm x 444 mm (27 in x 17 in x 17.5 in.)
Net Weight:	21 kg (46 lbs.)
LF Driver:	Integral frame with one 15" (380 mm) driver, dual neodymium magnet, 2" differential drive voice-coil.
HF Driver:	JBL 2418H-1 1" (throat diameter) compression driver with 1.75" diameter titanium diaphragm. Ferro-fluid cooled.
Amplifier Power LF:	300 watts @ low-frequency driver impedance.
Amplifier Power HF:	100 watts @ high-frequency driver impedance.
Input 1 Sensitivity:	-44 dBu to -22 dBu for rated output (Mic/Line switch in MIC position) -12 dBu to +20 dBu for rated output (Mic/Line switch in LINE position)
Input 2 & 3 Sensitivity:	-18 dBu to +20 dBu for rated output
Output Level:	+20 dBu (peak), Loop/Mix switch in MIX position
Audio Connectors:	
• Input 1:	XLR/F, balanced
• Input 2 & 3:	1/4" Phone, balanced (TRS)
Crossover Freq:	1.5 kHz
Limiting:	Low frequency amplifier controlled by dynamic filter
Loop/Mix Out:	XLR/M, balanced
EQ:	High Frequency Shelving, ±15 dB @ 5 kHz Low Frequency Shelving, ±15 dB @ 120 Hz.
AC Input:	110 - 230 VAC, 50 - 60 Hz., 175 watts rating per UL, detachable IEC power cable



Control[®] 30

Three-Way High Output Indoor/Outdoor Monitor Speaker

Professional Series

Key Features:

- ▶ Extended bandwidth, extremely smooth frequency response.
- ▶ Fully outdoor-capable design, featuring WeatherMax™.
- ▶ 120° x 110° HF coverage.
- ▶ 150 Watt transformer for 70V or 100V lines, with 8Ω thru.
- ▶ SonicGuard® overload protection
- ▶ 250 mm (10 in) fiberglass/Kevlar® cone LF woofer, with neodymium magnet coaxial 125 mm (5 in) anodized aluminum cone MR, and 25 mm (1 in) titanium diaphragm compression driver.
- ▶ Includes InvisiBall® mounting hardware, plus ten 6 mm attachment points for suspension and optional U-bracket.
- ▶ Sealed input panel cover and screw-down input terminals.

Applications

The Control 30 utilizes high power components, computer optimized horn and coaxial component design, patent-pending cabinet manufacturing techniques, and a complex network to achieve smooth high fidelity performance, extended bandwidth and well-controlled, defined coverage from a compact loudspeaker.

A symmetrical mid-high frequency horn allows use of the speaker in either vertical or horizontal orientation. Smooth frequency response and cone-midrange performance ensures excellent sound character throughout the frequency band, over the entire listening area.

The top-quality line distribution transformer, designed for minimal insertion loss and reduced saturation, allows use of either 70V or 100V distributed speaker lines. In bypass position, the 8 ohm impedance allows use of multiple speakers on a loudspeaker line.

The included InvisiBall mounting method is simple to install, aims easily and provides a high degree of theft deterrence. InvisiBall allows horizontal rotation of up to 41° off-axis and vertical rotation of up to 36° (horn end inward) or 23° (woofer end inward). Attachment points for the optional MTC-30UB (-WH) U-bracket allows for compact installation and is particularly useful for low profile underbalcony applications.

Weather resistance has been maximized. The neodymium magnet LF woofer has a fiberglass and Kevlar composite cone, the surround is pure butyl rubber, and the basket is rear loaded to minimize exposure. The MR cone of the coaxial mid-high driver is anodized aluminum with a formulation EPDM rubber surround, and the HF compression driver's diaphragm is pure titanium. The coaxial component is protected by an acoustically transparent screen. The grille is thermoset composite coated and stands up very well to UV as well as humidity. The grille is backed with our WeatherMax multi-layer foam, which prevents the direct incursion of water. Nickel/zinc rust-resistant terminals ensure a secure input connection. An MTC-PC2 sealed-entrance cover is included to further protect the speaker's terminals.

JBL's exclusive SonicGuard overload protection is virtually inaudible to the listener, ensuring reliability while providing full fidelity sound.

Available in black or white (-WH), the cabinet will accept a variety of paints to match any décor.



Specifications:

Frequency Range (-10 dB):	38 Hz – 17 kHz
Frequency Response (± 3 dB):	40 Hz – 16 kHz
100 Hr Power Capacity:	500 Watts Continuous Program Power 250 Watts Continuous Pink Noise
Maximum SPL @ 1m ¹ :	Short-Term: 123 dB; Long-Term: 117 dB
Nominal Sensitivity ² :	93 dB, 1W @ 1m (3.3 ft)
Nominal Coverage Angle ³ :	120° H x 110° V
Directivity Factor (Q):	5.2, averaged 500 Hz to 10 kHz
Directivity Index (DI):	7.1 dB, averaged 500 Hz to 10 kHz
Nominal Impedance:	8 ohms
Crossover Type:	3rd order Low Pass LF, 2nd order High Pass/3rd order Low Pass MF, 3rd order High Pass, HF, plus conjugate shaping circuitry.
Transformer Taps:	70V; 150W, 75W, 38W, 19W 100V: 150W, 75W, 38W Thru Position: 8Ω nominal
Recommended High-Pass:	See Chart
Transducers:	
Low Frequency:	250 mm (10 in) fiberglass/Kevlar® cone with pure butyl rubber surround, 50 mm (2 in) voice coil on fiberglass former, neodymium magnet
Mid Frequency:	125 mm (5 in) anodized aluminum cone with EPDM rubber (Terpolymer of Ethylene and Propylene) surround, 25 mm (1 in) voice coil on fiberglass former
High Frequency:	25 mm (1 in) compression driver, pure titanium diaphragm with patented JBL diamond surround
Physical:	
Enclosure Material:	High Impact PolyStyrene (HIPS) with 10% glass fill plus patent-pending internal 5 mm foamed polyurethane secondary mold
Grille:	Thermoset composite coated steel, WeatherMax multi-layer foam
Overload Protection:	SonicGuard full range power limiting to protect network and transducers.
Environmental:	IEC 529 IP-X5 rating. Exceeds Mil Spec 810 for humidity, salt spray, temperature & UV. Passes Mil-Std-202F for salt spray.
Termination:	Screw-down terminal strip, zinc plated copper base, nickel plated metal screws/washers. Accepts up to 9 mm outside 4 mm inside open lug (#6, #8 or #10 lug), plus bare wire (up to 12 AWG/2.5 mm ²).
Safety Agency Rating:	Transformer is listed per UL1876
Colors:	Black or white (-WH)
Dimensions (H x W x D):	593 x 372 x 345 mm (23.3 x 14.6 x 13.5 in)
Weight (ea):	18.9 kg (42 lb)
Shipping Weight (ea):	20.3 kg (45 lb)
Included Accessories:	1 pc MTC-PC2 input panel cover, InvisiBall mounting base, 6 mm x 305 mm InvisiBall Hex wrench.
Optional Accessories:	MTC-30CM (-WH) to install speaker down from the ceiling. MTC-30UB (-WH) U-Bracket

¹In Half Space

²Continuous Pink Noise rating is IEC-shaped pink noise with a 6 dB crest factor for 100 hours continuously. Continuous Program Power is defined as 5 dB above the Continuous Pink Noise Rating and is a conservative expression of the system's ability to handle normal speech and music program material.

³Calculated from sensitivity and power handling, exclusive of power compression.

⁴Half-space, averaged 100 Hz to 10 kHz

⁵500 Hz to 10 kHz

JBL continually engages in research related to product improvement. Changes introduced into existing products without notice are an expression of that philosophy.



Control[®] 29AV High Output Indoor/ Outdoor Monitor Speaker

Professional Series

Key Features:

- ▶ Extended bandwidth, extremely smooth frequency response.
- ▶ 110° x 85° HF coverage, rotatable horn.
- ▶ 110 Watt transformer for 70V or 100V lines, with 8Ω thru.
- ▶ SonicGuard™ overload protection.
- ▶ 200 mm (8") Kevlar cone woofer, 25 mm (1") titanium diaphragm compression driver.
- ▶ Includes InvisiBall™ mounting hardware, plus ten 6 mm attachment points for suspension and optional U-bracket.
- ▶ Sealed input panel cover and screw-down input terminals.

The Control[®] 29AV utilizes high power components, computer optimized horn and cabinet design and complex network to achieve smooth high fidelity performance, extended bandwidth and well-controlled defined coverage from a compact loudspeaker.

A rotatable high-frequency horn allows use of the speaker in either vertical or horizontal orientation. Smooth frequency response and even coverage ensures excellent sound character throughout the listening area. Partial magnetic shielding allows use of the speaker as close as 230 mm (9") to video monitors.

The top-quality line distribution transformer, designed for minimal insertion loss and reduced saturation, allows use of either 70V or 100V distributed speaker lines. In bypass position, the high 8Ω impedance allows use of multiple speakers on a loudspeaker line.

The included InvisiBall mounting method is simple to install, aims easily and provides a high degree of theft deterrence. InvisiBall allows horizontal rotation of up to 41° off-axis and vertical rotation of up to 36° (horn end inward) or 23° (woofer end inward). Attachment points for the optional MTC-29UB U-bracket allows for compact installation and is particularly useful for low profile underbalcony applications.

Weather resistance has been maximized. The woofer's cone is made of kevlar, surround is pure butyl rubber, and the driver basket is rear loaded to minimize direct exposure. The compression driver's diaphragm is pure titanium. The grille is thermoset composite coated and comes with foam to minimize incursion of water. Nickel/zinc rust-resistant terminals ensure a secure input connection. An MTC-PC2 sealed-entrance cover is included to further protect the speaker's terminals.

JBL's exclusive SonicGuard overload protection is virtually inaudible to the listener, ensuring reliability while providing full fidelity sound.



Available in black or white (-WH). The cabinet will accept a variety of paints to match any décor.

Specifications:

Frequency Range (-10 dB) ¹ :	40 Hz – 19 kHz
Frequency Response (± 3 dB) ¹ :	45 Hz – 18 kHz
100 Hr Power Capacity ² :	300 Watts Continuous Program Power 150 Watts Continuous Pink Noise
Maximum SPL @ 1m ³ :	Short-Term: 120 dB; Long-Term: 114 dB
Nominal Sensitivity ⁴ :	91 dB, 1W @ 1 m (3.3 ft)
Nominal Coverage Angle ⁵ :	110° H x 85° V, rotatable
Directivity Factor (Q):	7.2, averaged 500 Hz to 16 kHz
Directivity Index (DI):	8.6 dB, averaged 500 Hz to 16 kHz
Nominal Impedance:	8 ohms
Minimum Impedance:	6.3 ohms @ 230 Hz
Crossover Type:	3rd order High Pass, 2nd order Low Pass with impedance compensation, 2.5 kHz crossover frequency
Transformer Taps:	70V: 110W, 55W, 28W & 14W 100V: 110W, 55W, & 28W Thru Position: 8Ω nominal
Recommended High-Pass:	See chart
Transducers:	
Low Frequency:	200 (8 in) kevlar cone with pure butyl rubber surround, 50 mm (2 in) voicecoil on fiberglass former
High Frequency:	25 mm (1 in) compression driver, pure titanium diaphragm with patented JBL diamond surround
Physical:	
Enclosure Material:	High impact polystyrene
Grille:	Thermoset composite coated steel
Overload Protection:	Full-range power limiting to protect network and transducers. Serviceable internal fuse to protect during exceptional overload conditions.
Environmental:	IEC 529 IP-X4 splashproof rating. Exceeds MilSpec 810 for humidity, salt spray, temperature & UV. Passes Mil-Std-202F for salt spray.
Termination:	Screw-down terminal strip, zinc plated copper base, nickel plated metal screws/washers. Accepts up to 9 mm outside 4 mm inside open lug (#6, #8 or #10 lug), plus bare wire (up to 12 AWG/2.5 mm ²).
Safety Agency Rating:	Transformer is listed per UL1876.
Colors:	Black or white (-WH)
Dimensions (H x W x D):	520 x 306 x 277 mm (20.5 x 12.0 x 10.9 in)
Net Weight (ea):	12.2 kg (26.8 lbs)
Shipping Weight (ea):	14.0 kg (30.8 lbs)
Included Accessories:	1 pc MTC-PC2 input panel cover, InvisiBall mounting base, 6 mm x 260 mm InvisiBall Hex wrench.
Optional Accessories:	MTC-29CM to install speaker down from the ceiling MTC-29UB U-bracket

¹ In Half-space.

² Continuous Pink Noise rating is IEC-shaped pink noise with a 6 dB crest factor for 100 hours continuously. Continuous program power is defined as 3 dB above the Continuous Pink Noise Rating and is a conservative expression of the system's ability to handle normal speech and music program material.

³ Calculated from sensitivity and power handling. Power compression not considered.

⁴ Half-space, averaged 100 Hz to 10 kHz ⁵ 2 kHz to 14 kHz

JBL continually engages in research related to product improvements. Changes introduced into existing products without notice are an expression of that philosophy.



Control[®] 25AV

Shielded Indoor/Outdoor Monitor Speaker

Professional Series

Key Features:

- ▶ Video shielded for use near video monitors.
- ▶ Extremely smooth frequency response.
- ▶ Stainless steel grille for harsh environments.
- ▶ 60 Watt transformer for 70V or 100V lines, with 8Ω thru.
- ▶ SonicGuard™ overload protection.
- ▶ 130 mm (5¼") polypropylene coated woofer, 10 mm (¾") titanium coated horn-loaded tweeter.
- ▶ Includes *InvisiBall*® mounting hardware and sealed input panel cover.
- ▶ Screw-down input terminals.
- ▶ 100° x 100° high frequency horn.

The Control[®] 25AV utilizes a deep cabinet, high power components and complex network to achieve extremely smooth high fidelity performance from a compact 2-way loudspeaker.

Premium performance capability and even coverage ensures excellent sound quality throughout the listening area.

Magnetic shielding allows use of the speaker in close proximity to video monitors.

The top-quality transformer, with reduced saturation, allows use on either 70 volt or 100 volt distributed speaker lines, with similar performance fidelity. In the bypass position, the high 8Ω impedance allows use of more speakers on a loudspeaker line.

The unique, global patent pending *InvisiBall*® mounting method is simple to install, aims easily, and provides a high degree of theft deterrence.

The cabinet accepts a variety of paints to match any décor.

Weather resistance is maximized by a stainless steel grille, which is paintable. Coating the woofer in polypropylene and terminating its circumference in JBL's *WeatherEdge*™, a seamless, butyl rubber extension of the woofer surround, protects critical transducer elements. The polycarbonate tweeter diaphragm is reinforced with a thin film of titanium for added rigidity and endurance. Nickel/zinc rust-resistant terminals ensure a secure input connection.

JBL's exclusive SonicGuard overload protection is virtually inaudible to the listener, ensuring reliability while providing full fidelity sound.

The Control 25AV can be used full range or low frequencies can be further augmented with the addition of one of the Control Contractor subwoofer models.

Available in black or white (-WH)



Preliminary Specifications:

Freq. Range (-10 dB):	70 Hz - 23 kHz
Midrange (±1.5 dB, typical):	130 Hz - 14 kHz
100 Hr Power Capacity:	200 Watts Continuous Program Power 100 Watts Continuous Pink Noise
Nominal Coverage:	100° x 100°
Nominal Sensitivity:	87 dB SPL, 1W @ 1 m (3.3ft)
Nominal Coverage:	100° x 100°
Maximum SPL @ 1m:	113 dB continuous peak pink noise 107 dB continuous average pink noise 103 dB continuous average music or speech
Directivity Factor (Q):	4.9, averaged 500 Hz to 4 kHz
Directivity Index (DI):	6.9 dB, averaged 500 Hz to 4 kHz
Nominal Impedance:	8 ohms
Minimum Impedance:	6.7 ohms at 230 Hz
Crossover Type:	Second Order Lowpass, Second Order Highpass, Complex Optimization for Maximally Flat Response
Transformer Taps:	70V: 60W, 30W, 15W, 7.5W taps (Taps #4, #3, #2 & #1) 100V: 60W, 30W, 15W taps (Taps #3, #2, & #1) Thru position: 8Ω nominal
Transducers:	
Low-Frequency:	130 mm (5.25 in) polypropylene-coated paper with WeatherEdge surround, 25 mm (1 in) voicecoil on kapton former
High-Frequency:	20 mm (.75 in) titanium coated PEI
Physical:	
Enclosure Material:	High Impact polystyrene
Grille:	Painted stainless steel, black or white to match cabinet, paintable
Overload Protection:	Full-range power limiting to protect network and transducers. Internal fuse to protect during exceptional overload condition
Environmental:	Exceeds Mil Spec 810 for humidity, salt spray, temperature & UV. IEC 529 IP-X4 splashproof rating
Termination:	Screw-down terminal strip, zinc-plated copper base, nickel plated metal screws/washers, accepts up to 9 mm outside 4 mm inside open lug (#6, #8 or #10), plus bare wire. (up to 12 AWG)
Safety Agency Rating:	Transformer is listed per UL1876
Colors:	Black or white (-WH)
Rotation:	Against wall on InvisiBall Base: 37° vertical 44° horizontal On bracket: 44° all directions
Dimensions (H x W x D):	236 x 186 x 159 mm (9.3 x 7.4 x 6.3 in)
Net Weight (ea):	4.0 kg (9 lbs)
Shipping Weight (pair):	9.0 kg (20 lbs) per pair
Included Accessories:	1 Pr MTC-PC input panel cover, InvisiBall mounting base, 6 mm x 100 mm InvisiBall hex wrench
Optional Accessories:	MTC-25V for vertical columnar mounting of up to 3 speakers MTC-25/23H for horizontal splaying of 2 speakers. Three brackets array either 3 or 6 speakers in a hanging array module for 360° horizontal coverage. MTC-28/25CM to install speaker down from the ceiling. Check JBL Control Contractor Bracket and Adapter Handbook.

¹In half-space (on wall).

²In full-space

³Continuous Pink Noise rating is IEC-shaped pink noise with a 6 dB crest factor for 100 hours continuously.

⁴Continuous program power is a conservative expression of the system's ability to handle normal speech and music program material and is defined as 3 dB above the Continuous Pink Noise Rating.

⁵Half-space (on wall) averaged 100 Hz to 10 kHz.

JBL continually engages in research related to product improvement. Changes introduced into existing products without notice are an expression of that philosophy.



Control[®] 26C/CT

Background/
Foreground
Ceiling Speakers

Professional Series

Key Features:

- ▶ Coaxially mounted 165 mm (6.5 in) woofer with butyl rubber surround and 19 mm (¾ in) titanium coated diffraction-loaded tweeter
- ▶ High power, wide frequency response and low distortion for high sound level capability
- ▶ Wide coverage allows fewer speakers, reducing the cost of the installed sound system without sacrificing performance
- ▶ JBL's exclusive SonicGuard™ overload protection allows higher operational levels and improved system reliability (26C only)
- ▶ Packaged with grille, backcan and tile rails for fast installation and easy dealer stocking

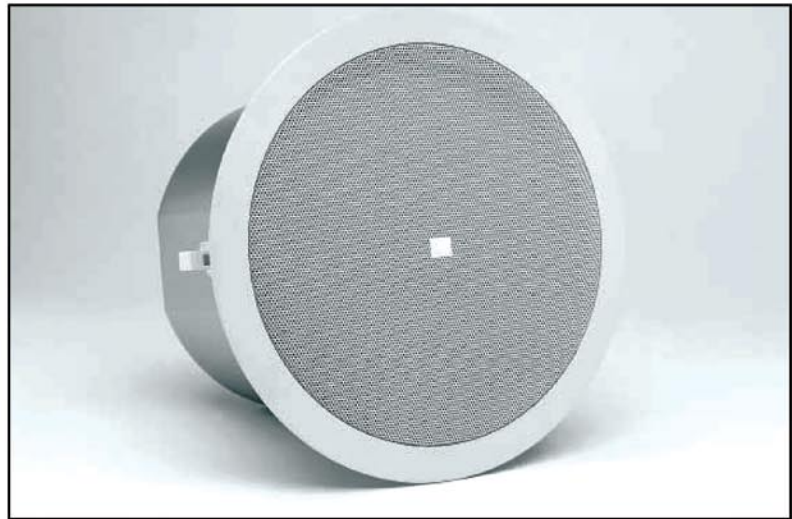

The Control 26C is a compact ceiling speaker providing premium performance in background, foreground music sound systems. The Control 26C is perfectly suited for a wide variety of applications from casinos and hotels to upscale restaurants and themed locations. High power handling, wide frequency response and low distortion make the Control 26C ideal for sound systems requiring a higher fidelity sound from ceiling loudspeakers. The premium performance capability ensures excellent sound character, providing pleasant, enveloping sound throughout the listening area.

The Control 26C's 16 ohm impedance allows use of multiple speakers in parallel without having to use a more expensive constant voltage distributed system. The optional Control 26CT version includes a multitap transformer for 70V/100V systems.

JBL's exclusive SonicGuard overload protection is a non-invasive loudspeaker protection system that is inaudible to the listener, ensuring reliability while providing full fidelity sound. The computer-optimized ported enclosure delivers warm, smooth bass response. Low frequency output can be further augmented with the addition of one of the Control Contractor subwoofer models.

The 165 mm (6.5 in) woofer features a polyurethane-coated cone and pure butyl-rubber surround for long life, even in high humidity environments. An aluminum voice coil former provides extra cooling for greater long-term power handling.

The coaxially mounted 19 mm (¾ in) titanium coated tweeter provides crisp, clear highs. Diffraction-loading of the tweeter provides wide, even coverage of the listening area. The extremely broad 110° coverage pattern allows for fewer speakers to be used, making for a simpler and less expensive installation.

Specifications:

System:	
Freq. Range (-10 dB) ¹ :	75 Hz - 20 kHz
Power Capacity ² :	150 Watts Continuous Program Power 75 Watts Continuous Pink Noise
Nominal Sensitivity ³ :	89 dB SPL, 1W @ 1 m (3.3 ft)
Nominal Coverage Angle ⁴ :	110° conical coverage
Directivity Factor (Q):	5.9 averaged 500 Hz to 4 kHz
Directivity Index (DI):	4.6 averaged 500 Hz to 4 kHz
Rated Maximum SPL:	107 dB @ 1 m (3.3 ft)
Nominal Impedance (26C):	16 ohms (Min Z 16.5 Ω @ 290 Hz)
Transformer Taps (26CT):	70V: 60W, 30W, 15W & 7.5W taps 100V: 60W, 30W, & 15W taps
Transducers:	
Low-Frequency:	165 mm (6.5 in) Polypropylene-coated, 1" coil on aluminum former
High-Frequency:	19 mm (¾ in) Titanium coated polyester
Physical:	
Enclosure:	Backcan: Formed steel Baffle/Rim: Medium impact polystyrene, fire rated UL94V-0
Overload Protection:	Full-range power limiting to protect network and transducers. (On Control 26C, not on Control 26CT)
Termination:	Removable locking connector with screw-down terminals. 2 input terminals and 2 loop-thru output terminals. Max. wire 12 AWG (2.5 mm ²)
Safety Agency Rating:	Suitable for use in air handling spaces, per U.L.-2043, U.L.-1480, NFPA90, NFPA70A
Outside Dimensions (H x Dia):	210 x 252 mm (8.3 x 9.9 in) 190 mm (7.5 in) front of ceiling tile to back of backcan
Cutout Size:	220 mm (8.75 in)
Net Weight (ea):	3.4 kg (7.5 lb) CT: 4.2 kg (10 lb)
Shipping Weight (pair):	8.1 kg (18.0 lb) CT: 9.7 kg (21 lb)
Included Accessories:	C-shaped support backing plate 2 tile support rails (fits both 2 x 4 ft or 600 x 1200 mm tiles)
	Cutout template Paint shield Removable locking wiring connector

¹Half-space (flush mounted in ceiling)

²Continuous Pink Noise rating is IEC-shaped pink noise with a 6 dB crest factor for 100 hours continuously. Continuous Program power is a conservative expression of the system's ability to handle normal speech and music program material and is defined as 3 dB above the Continuous Pink Noise Rating.

³Half-space (in ceiling), average 100 Hz to 10 kHz

⁴500 Hz to 4 kHz

JBL continually engages in research related to product improvement. Changes introduced into existing products without notice are an expression of that philosophy.



SMS1 Business Music System



SMS1 Soundzone® Music System is a complete business music system for background or foreground music applications such as retail stores, restaurants and other businesses. Fully self-contained with four satellite speakers and the SMS1 base station, the system comes complete with power amplification for all speakers, a controller for a music source and for one paging microphone, and a subwoofer for providing full range, clear natural sound.

SMS1 is a quick-install, easy to use system for businesses with up to 2500 square feet. The SMS1 Soundzone Music System delivers full fidelity music and clear paging with audio quality that customers expect from JBL.

Key Features

- ▶ Premium sound quality
- ▶ Extremely easy for end-users to operate
- ▶ A complete self-contained system*, including:
 - Four mini satellite loudspeakers
 - One subwoofer
 - Self-powered
 - Advanced system controller
- ▶ Built-in controller contains advanced features for business applications:
 - AutoWarmth® (provides full sound at all volumes)
 - LevelGuard™ (keeps music level in check)
 - Connects to optional wallplate for remote control of volume
- ▶ Optional Soundzone paging microphone
- ▶ Available in Charcoal Grey or white

*Requires a music source

System Components

SMS1-Sub

This subwoofer reproduces the lower frequencies necessary for full range music and audio. The SMS1-Sub contains amplification for the four satellite speakers and for the subwoofer. It also contains the built-in system controller.

Controller

The controller built into the SMS1-Sub provides the following features:

AutoWarmth - Uses patented signal processing to add fullness at lower levels and to reduce boominess at higher volumes, providing optimum sound at all volume levels.

LevelGuard - Automatically selects the correct amount of sonic compression for best sound quality despite excessive level changes from the music source.

Page Ducking - Automatically lowers the music when the microphone is in use and smoothly ramps the music back after the page is complete.

Inputs - The controller allows one music source (such as programmed music, CD player, tuner, or tape player) and one paging microphone. A wide variety of input levels and types are accommodated, including balanced line level (the preferred input, where possible), speaker level, and unbalanced (RCA) line level. [If more than one music source is required, see "Using SMS1 with a Soundzone Controller", below.]

SMS1-Sat Speakers

Four unobtrusive satellite speakers complete the SMS1 system. Each speaker measures just 5 1/4" x 3 1/4" x 3 1/2" (135 x 84 x 95 mm). The SMS1-Sat speakers are installed easily



using JBL's patented Invisibal® mounting system, which allows for a wide range of adjustment in a unique theft-resistant design.

Configurations

SMS1 as a Standalone System

The primary intended configuration is as a standalone system. SMS1 can provide quality audio for businesses up to 2500 square feet.

Using SMS1 with a Soundzone Controller

For sound systems requiring more than one music source, or requiring more advanced engineered capabilities (such as emergency override, music-on-hold send, music priority automatic override settings, etc.), but not requiring additional SPL capability, the SMS1 system can be used in conjunction with the JBL Z32S or Z21S Soundzone Business Music Controllers.

In such an engineered system, all sources and any control systems should be connected to the Soundzone Controller, with the output of the Controller run to the SMS1 input.

SMS1 Systems in Multiples

Multiple SMS1 systems can be utilized to cover larger areas, simply by paralleling the source and mic (if one is used) to the inputs of the two systems. [See note on specification page

discussing long signal lines.] In addition, multiple SMS1 systems can be driven from the zone output of a Soundzone Business Music Controller to cover larger areas simply by running the output of the Controller to the inputs of the multiple SMS1 systems. If remote volume control by zone is desired, each SMS1 zone has its own remote volume capacity.

SMS1-Sub - By Itself - The SMS1-Sub, can be utilized without the satellite speakers for augmenting the bass capability of a larger JBL Control Contractor in-ceiling or on-wall speaker system. The bass augmentation system can consist of a single SMS1-Sub, if it provides sufficient bass capability, or multiple SMS1-Subs can be utilized for additional bass capability or to cover a larger area.

Driving Different Satellite Speakers - The SMS1-Sub can be used to drive different satellite speakers, such as JBL Control 24C/CT Micro In-Ceiling loudspeakers. When doing so, a switch is provided on the input panel to bypass the SMS1-Sat specific EQ curve, thus driving the satellite speakers with an electrically flat audio signal. It is necessary to observe minimum impedance considerations (4 ohm minimum per channel).

Positioning the SMS1-Sub

The SMS1-Sub is intended primarily for permanent installation onto a wall. It can also be positioned on a horizontal shelf surface using the included leg brackets. [Note: SMS1-Sub should always be used in an upright position for proper air flow to cool the built-in power amplifier.]

Boundary Placement vs. Output Level - Placement on the center of the wall, away from ceiling or other wall will usually result in adequate bass output level. Additional bass level can be attained by placing the SMS1-Sub within 4 feet of the ceiling or another wall. Maximum bass output is attained by installing the SMS1-

Sub in the corner junction of two walls and the ceiling (or two walls and the floor).

Power and Audio Wiring Options

SMS1-Sub has been designed to accommodate a wide variety of wiring options. Installation and wiring must be implemented in accordance with local building codes and requirements. Following are a few of the installation possibilities.

When SMS1-Sub is permanently installed onto a wall, the cleanest way to route the AC and audio signal wires is through the wall, entering the SMS1-Sub through the back of the unit. AC and audio cables can be kept separated via independent cutouts on the back of the SMS1-Sub's wallpanel.

Installing In-Wall Electrical Boxes Electrical boxes can be installed into the wall behind the SMS1-Sub prior to installation of the SMS1-Sub.

There are recesses in the back of the SMS1-Sub's wallpanel allowing clearance for wallbox covers, and there are cutouts in the back of the SMS1-Sub's wallpanel to allow for wire entrance.

Using Included Internal Boxes - Power wiring can be run through the wall into the included electrical knockouts on the inside of the SMS1-Sub's wallpanel. Audio can be run into the SMS1 using the second cutout in the SMS1-Sub's wallpanel.

Surface Conduit - For locations requiring cables to be run on the surface of the wall, SMS1-Sub has been designed to accommodate both power and audio cabling to enter via two separate knockouts in the top grille. The internal electrical box is provided for terminating the conduit inside the SMS1-Sub. Alternatively, the installer can choose to install a wallbox of their choosing onto the inside of the SMS1-Sub's wallpanel to terminate the conduit.

Ease of Setup & Ease of Use

SMS1 Complete System - When using SMS1 as a self-contained system, switches are marked with a "normal" position. The end user simply adjusts the music volume and paging volume. Functions such as AutoWarmth and LevelGuard are automatic, and setup controls are protected from tampering. Typically, no special training of end users is required.

Special Situation Settings:

SMS1 By Itself - When using the SMS1-Sub by itself to augment another sound system, set the Crossover switch to "80 Hz" to avoid muddy overlap with full-range speakers.

Driving Other Satellite Speakers - When using the SMS1-Sub to drive satellite speakers that are not SMS1-Sats, set the Speaker EQ switch to "off", bypassing the internal EQ that is specifically set up for SMS1-Sats.

Included Accessories

- SMS1-Sub Wallpanel
- SMS1-Sub Internal Electrical Box
- SMS1-Sat Invisiball Mounts
- 3 mm wrench for SMS1-Sat Invisiball
- Connectors, wire clips

JBL continually engages in research related to product improvement. Some materials, production methods and design refinements are introduced into existing products without notice as a routine expression of that philosophy. For this reason, any current JBL product may differ in some respect from its published description, but will always equal or exceed the original design specifications unless otherwise stated.

Specifications

POWER CAPABILITY

SMS1-Sub:	80 Watts Continuous pink noise 160 Watts Continuous program 320 Watts peak
SMS1-Sat:	10 Watts Continuous pink noise (x 4 speakers) 20 Watts Continuous program (x 4 speakers) 40 Watts peak (x 4 speakers)
SPL Capability (1m):	
SMS1-Sub:	104 dB average, 110 dB peak.
SMS1-Sat:	92 dB average, 98 dB peak (x 4 speakers)
Frequency Range (± 10 dB):	40-16 kHz
Frequency Response (± 3 dB):	45-13 kHz

INPUT

Music:(use only one of the following):	Pro Line Level Input: +4 dBu nominal, balanced, Euroblock connector Consumer Line Level Input: -10 dBV nominal, unbalanced, RCA connector. (See Note 1, below if using the Consumer Line Input) Speaker Level Input: For low impedance speaker lines or for 70V/100V speaker lines, Euroblock connector
Microphone:	Balanced, Euroblock connector, switchable phantom power for condenser microphones. Band limited 200 Hz - 8 kHz.
Internal Crossover:	24 dB/oct low-pass to the subwoofer amp/driver. 24 dB/oct high-pass to the satellite amp/speakers.
Remote Volume Control Jack:	RJ45 connector, for standard UTP Category 5 cable. Uses ZR-V remote wallplate.

SETTINGS:

PROTECTED CONTROLS

Subwoofer Polarity:	Sets the polarity of the input signals so the bass to the subwoofer adds properly. Positions: In Polarity (Normal) Out of Polarity.
Crossover:	Sets the crossover frequency of the subwoofer. Positions: 160 Hz (Normal) - for normal operation of SMS1 system. 80 Hz - When using SMS1-Sub to augment the bass of another speaker system, to avoid muddy overlap with fullrange speakers.
Bass Trim:	Adjusts subwoofer level relative to that of the satellite speakers. Control: Variable rotary control
AutoWarmth:	AutoWarmth automatically adjusts tonal balance to sound full at low volumes. Indicator: LED, lights when AutoWarmth is active. Control: Variable rotary control
Page Threshold:	Adjusts threshold at which microphone signal triggers music ducking.
Speaker EQ:	Built-in EQ is specifically set up for SMS1-Sats. Positions: On (Normal), Off
USER ACCESSIBLE CONTROLS:	
Music:	Adjusts volume of music source
Mic:	Adjusts volume of the paging microphone

MODELS

SMS1	Charcoal Grey, 120 VAC
SMS1-WH	White, 120 VAC
SMS1/230	Charcoal Grey, 230 VAC
SMS1-WH/230	White, 230 VAC
SMS1-SUB	Powered Subwoofer, Charcoal Grey, 120 VAC
SMS1-SUB-WH	Powered Subwoofer, White, 120 VAC
SMS1-SUB/230	Powered Subwoofer, Charcoal Grey, 230 VAC
SMS1-SUB-WH/230	Powered Subwoofer, White, 230 VAC
	SMS1/100, SMS1-WH/100, SMS1-SUB/100, SMS1-SUB-WH/100

OPTIONAL ACCESSORIES

Z-M1 Paging Microphone:	Dynamic (leave phantom power off), 600 ohms, balanced
ZR-V Remote Wallplate:	Wallplate for remote adjustment of music volume
ZR-IWB In-Wall Electrical Box:	U.S. Size electrical box for use with ZR-V. For countries where U.S. size boxes are not available. Contains side dogear clamps to clamp onto wall surface.
ZR-OSB On-Surface Electrical Box:	U.S. Size electrical box for use with ZR-V. For countries where U.S. size boxes may not be available. Mounts on the surface of the wall.

Note 1: If positioning of the subwoofer requires the use of an audio line longer than 3 meters, do not use the unbalanced (RCA) input. Instead, buffering and/or balancing of the signal via an external device at the source is required in order to make sure the audio fidelity is not compromised before getting to the SMS1 system.

Dimensional Drawing

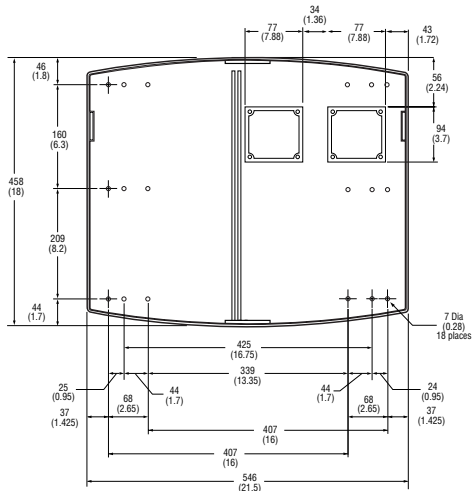

SMSI-Sub Wallpanel

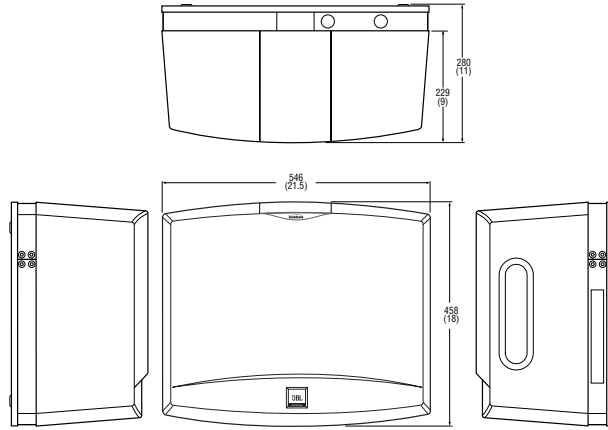

SMSI-Sub Subwoofer

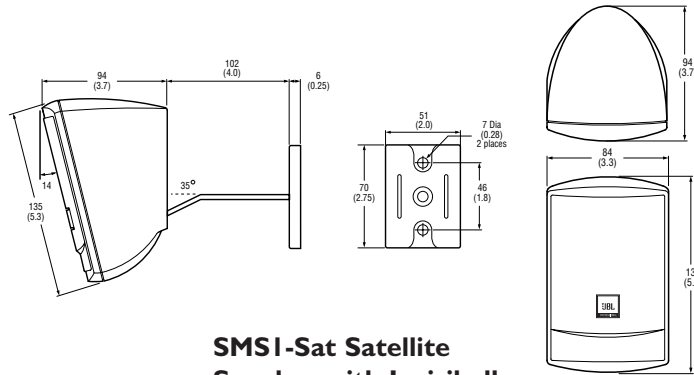

SMSI-Sat Satellite Speaker with Invisiball Bracket Plate

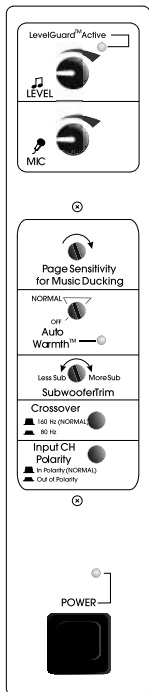

SMSI Connection and Control Panel

Dimensions in mm (inches)

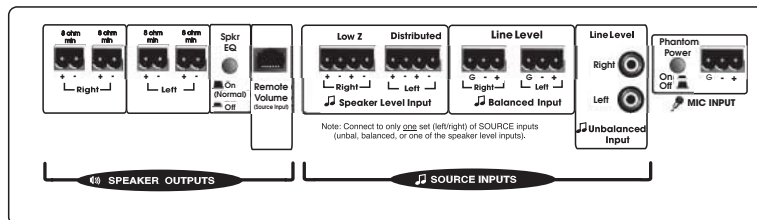

JBL Professional
8500 Balboa Boulevard, P.O. Box 2200
Northridge, California 91329 U.S.A.
www.jblpro.com

H A Harman International Company
© Copyright 2001 JBL Professional

SSSMS1
CRP 1.5M
11/01

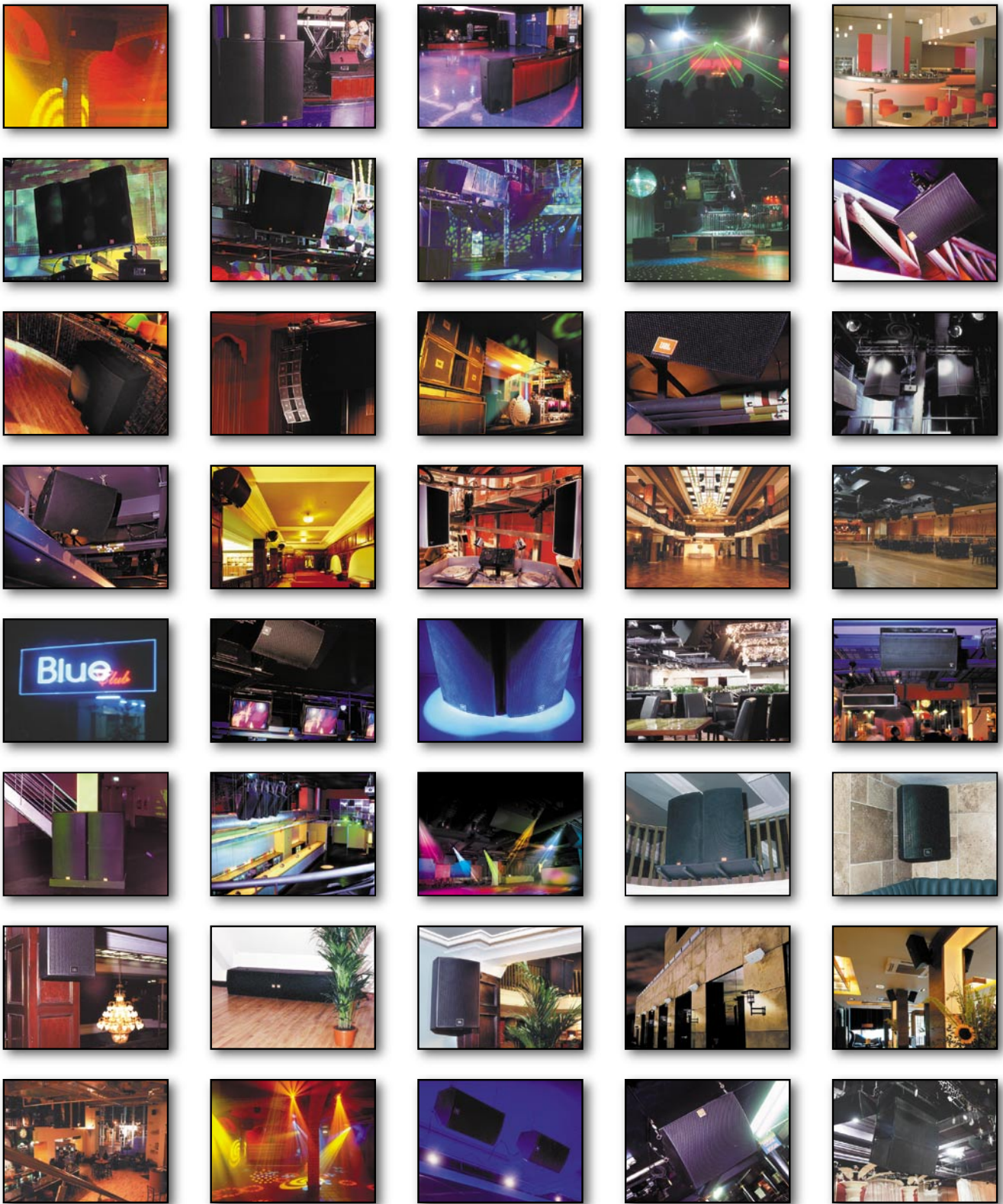

H A Harman International Company