

K151 "W" Horn

In answer to long-standing requests from dealers and end users, JBL is pleased to make available this plan for user construction of a "W"-format folded horn designed specifically for the JBL K151 18-inch loudspeaker.

The K151 "W"-box provides a 4dB sensitivity increase above 40Hz and a usable response from 32Hz to 400Hz. The horn mouth size of this enclosure is 1/8 of the size required for a full 40Hz horn. Hence, stacking 8 JBL "W"-boxes in a 4 x 2 configuration will provide true horn loading down to 40Hz.

These low frequency systems can be used as woofers in discotheques, bass guitar or organ pedal systems, or, when stacked in multiples, as the low end section of a three or four-way rock reinforcement system.

Because of the inherent midrange coloration of any "W"-horn design, the recommended crossover frequency is 300Hz or lower.

Construction Notes

These plans are designed for 3/4" high density fir plywood. All joints must be glued and secured with 1-1/4" #8 wood screws spaced every 5 inches. Although omitted from the plans for clarity, all butt joints require 1" x 1" glue blocks running the length of each joint in order to maintain structural rigidity. If the enclosure will be used in portable or road service, heavier bracing may be required.

All interior surfaces of the chamber in which the K151 is mounted (except for the baffle panel) should be lined with 1" fiberglass. This may be attached to the walls with staples or glue.

Piece 7 is a removable panel which allows access to the chamber for mounting the K151. The shortest dimension of the opening covered by piece 7 must be no less than 7-5/8" so that the loudspeaker will fit into the chamber. Piece 7 should be secured to pieces 13 and 14 with at least 10 #10-32 screws and T-nuts. Foam tape or caulking installed around the perimeter of the access opening will maintain the required air seal.

The K151 is secured to piece 15 by eight screws and T-nuts. The T-nuts should be installed in piece 15 before it is assembled to piece 6. The K151 bolt hole circle is 17-3/8" and the T-nut should be installed at 45° increments.

No provision for connecting the loudspeaker to an amplifier is shown. The builder should select the connection method most suitable for his system.

:lw

"W" Horn for K151 18" Driver

A medium-throw "W" folded horn with vented-box rear air chamber for use with our K151 18" driver providing uniform response from 55 Hz to 400 Hz when used singly in half-space environment. Its folded configuration allows a full 4 ft. long 40 Hz flare-rate exponential horn to be packaged in a relatively compact enclosure. A 5 cu. ft. 35 Hz tuned vented-box rear air chamber provides useable response and full 150 watt power handling capacity down to 32 Hz. The horn is designed to be used in multiples (2 to 8 units) to provide flat response to below 40 Hz in environments where reflective surfaces are not available. A single unit can generate some 15 to 20 acoustic watts at full power input in the 60 to 400 Hz range with less than 3% harmonic distortion.

SPECIFICATIONS:

For single unit in Half-Space (single reflective surface).

Frequency Response:*

Axial SPL: 60 Hz to 1 K Hz \pm 3dB

Power: 55 Hz to 400 Hz \pm 3dB

*Both on axis and total acoustic power frequency responses are given for the system. The axial response gives the output under free-field or outdoor conditions (or the direct-field in a reverberant space) while the power response indicates what one should expect if the system is used in a reverberant indoor or enclosed space.

Sound Pressure Level:

(re 20 uPa, nominal impedance assumed)

at 1 m (3.3 ft), 1 watt input:

103 dB (Ave. 80 to 400 Hz)

at 1 m, full power (150 watts) input:

124 dB (Ave. 80 to 400 Hz)

Efficiency:

15% (Ave. 80 to 400 Hz)

Maximum Input Power:

(Nominal impedance assumed)

Continuous (narrow band or sinewave):

150 watts (above 32 Hz)

50 watts (below 32 Hz)

Instantaneous Peak:

1500 watts *

*Peaks 10 dB above stated continuous maximum power inputs are permissible as long as the true RMS power averaged over any one second interval remains within continuous limits.

Beamwidth:

The beamwidth information gives the approximate coverage angles of the system between the 6-dB-down points from on axis.

Horizontal: No less than 60° up to 400 Hz.

Vertical: No less than 45° up to 400 Hz.

Impedance:

	K151-4	K151-8
Nominal	4 ohms	8 ohms
Minimum	3 ohms	6 ohms

PARTS LIST K 151 "W" BOX

<u>ITEM</u>	<u>DESCRIPTION</u>	<u>DIM. (INCHES)</u>	<u>QUANTITY</u>
1	Back	3/4 x 24 x 48	1
2	End	3/4 x 22 1/2 x 29 1/4	2
3	Side	3/4 x 30 x 48	2
4	Brace 1	3/4 x 18 1/4 x 22	2
5	Chamber Side	3/4 x 22 1/2 x 23 1/2	2
6	Baffle 1	3/4 x 22 1/2 x 29	1
7	Port Plate	3/4 x 22 1/2 x 10	1
8	Horn Plate 1	3/4 x 10 9/32 x 6 1/2	2
9	Horn Plate 2	3/4 x 10 1/2 x 6 1/2	4
10	Horn Plate 3	3/4 x 9 1/4 x 22 1/2	2
11	Horn Plate 4	3/4 x 5 11/16 x 13	1
12	Horn Plate 5	3/4 x 4 15/16 x 13	1
13	Brace 2	3/4 x 3/4 x 21	2
14	Brace 3	3/4 x 3/4 x 7 5/8	2
15	Baffle 2	3/4 x 22 1/2 x 27 1/2	1

REVISIONS
 CHG | LTR | DESCRIPTION | DATE | CHK | DATE | APPR

REVISIONS
 CHG | LTR | DESCRIPTION | DATE | CHK | DATE | APPR

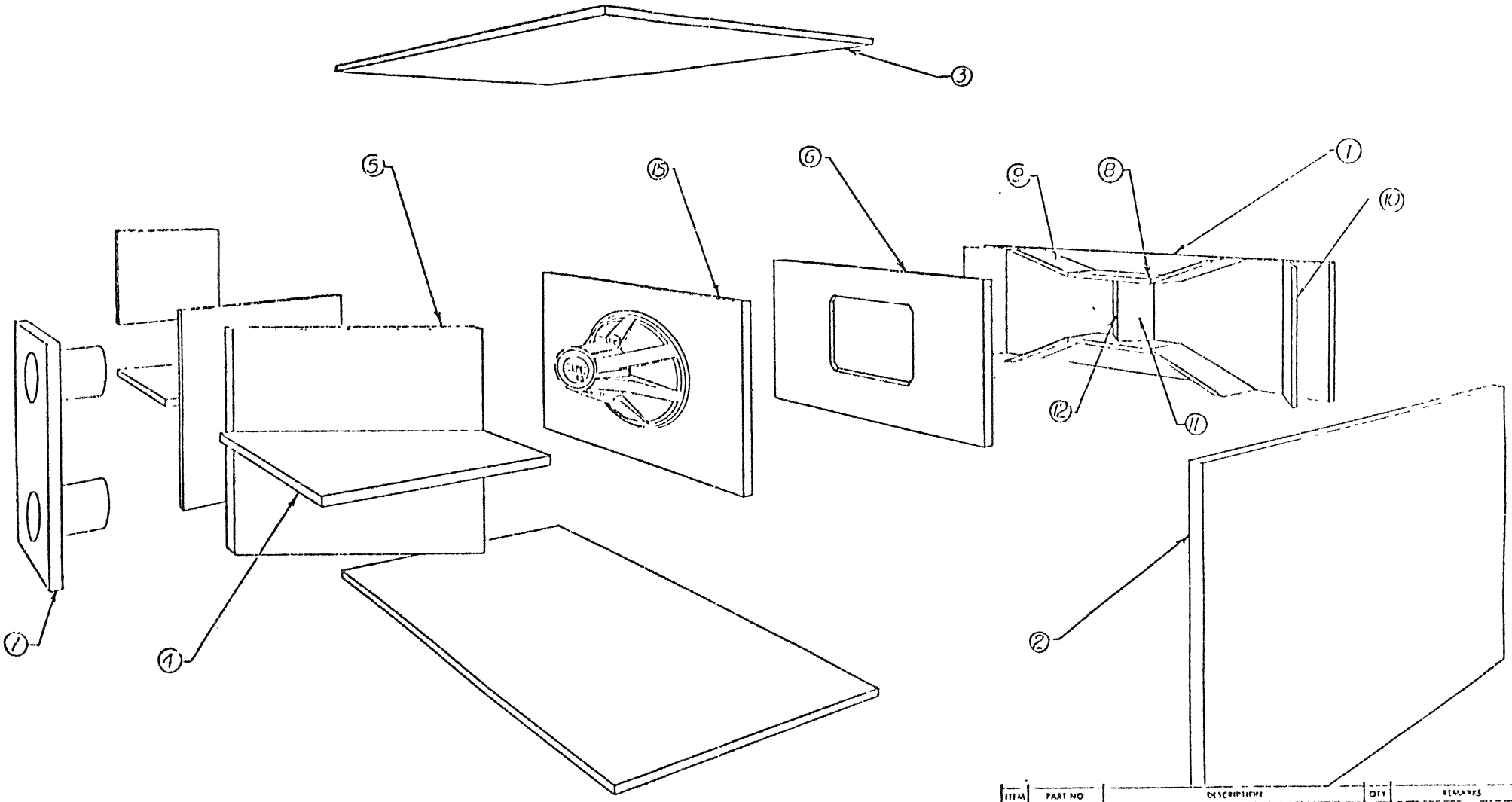

ITEM	PART NO	DESCRIPTION	QTY	REMARKS
BILL OF MATERIAL				
<small>UNLESS OTHERWISE SPECIFIED, ALL DIMENSIONS ARE IN INCHES AND FRACTIONS THEREOF. DIMENSIONS IN PARENTHESES ARE IN MILLIMETERS. DIMENSIONS IN PARENTHESES TAKE PRECEDENCE OVER DIMENSIONS IN INCHES.</small>		<small>DATE: 10/1/50</small>		<small>BY: JAMES R. LINDSAY</small> <small>CHKD: JAMES R. LINDSAY</small> <small>APPD: JAMES R. LINDSAY</small>
<small>QUANTITY: 100</small> <small>UNIT: EACH</small>		<small>DESCRIPTION: RECTANGULAR PANEL</small>		<small>11</small>
<small>PREPARED BY: J. R. LINDSAY</small> <small>DATE: 10/1/50</small>		<small>APPROVED BY: J. R. LINDSAY</small>		<small>11</small>
<small>NOT TO BE USED FOR ANY OTHER PURPOSE</small>				

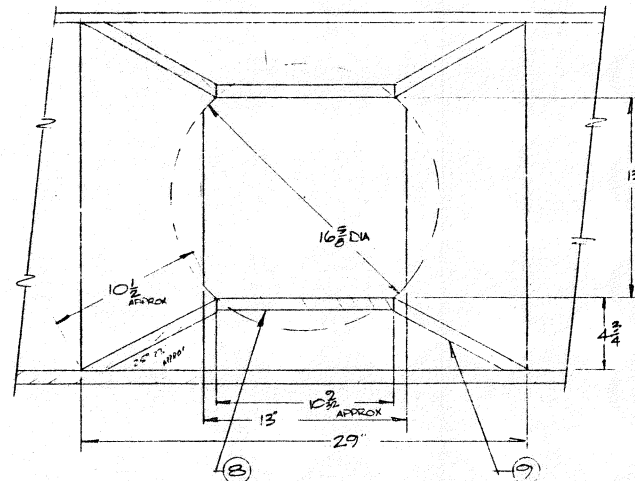
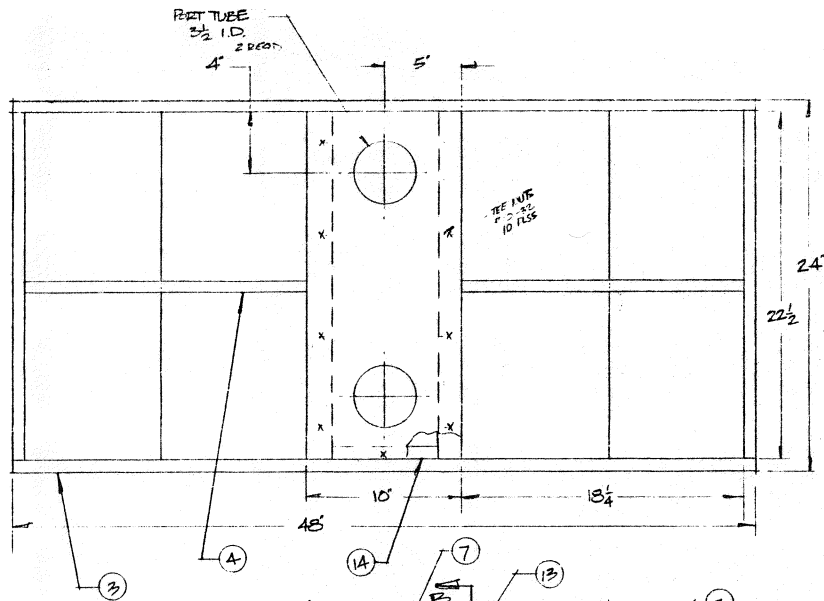

VIEW A-A
BACK PNL & ITEMS 11 & 12 REMOVED FOR CLARITY

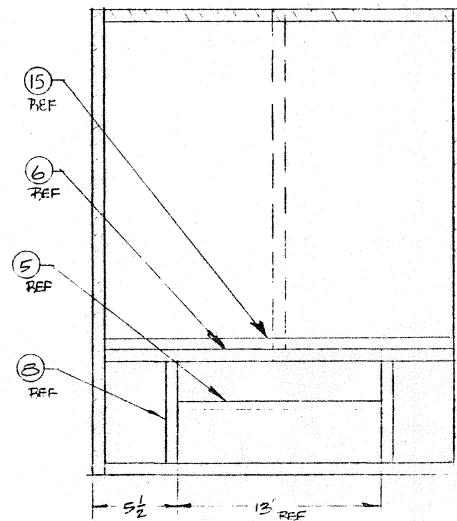
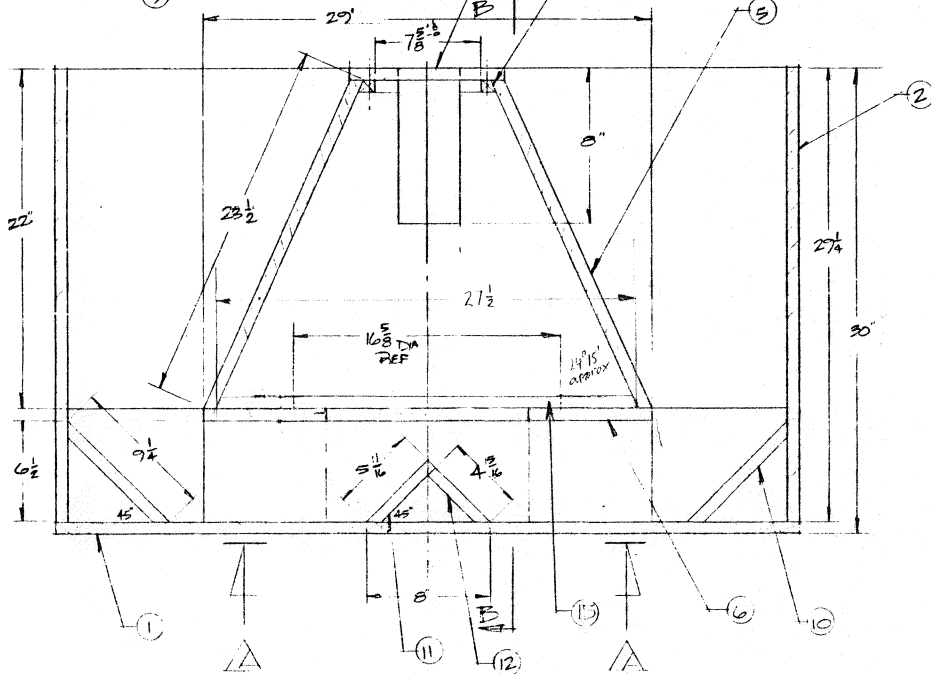

SECT B-B

- | | | |
|----|-----------------------|--------|
| 1 | 3/4 x 24 x 48 | 1 RECD |
| 2 | 3/4 x 22 1/2 x 29 1/4 | 2 RECD |
| 3 | 3/4 x 30 x 48 | 2 RECD |
| 4 | 3/4 x 18 1/4 x 22 | 2 RECD |
| 5 | 3/4 x 22 1/2 x 29 1/4 | 2 RECD |
| 6 | 3/4 x 22 1/2 x 29 | 1 RECD |
| 7 | 3/4 x 22 1/2 x 10 | 1 RECD |
| 8 | 3/4 x 10 3/8 x 6 1/2 | 2 RECD |
| 9 | 3/4 x 10 1/2 x 6 1/2 | 4 RECD |
| 10 | 3/4 x 9 1/4 x 22 1/2 | 2 RECD |
| 11 | 3/4 x 5 1/16 x 13 | 1 RECD |
| 12 | 3/4 x 4 1/16 x 13 | 1 RECD |
| 13 | 3/4 x 9/4 x 21 | 2 RECD |
| 14 | 3/4 x 3/4 x 7 3/8 | 2 RECD |
| 15 | 3/4 x 22 1/2 x 27 1/4 | 1 RECD |

W' HORN FOR SINGLE 18" (KISI)

SCALE: DATE 3-6-78 JRF
MATERIAL: 3/4 PLYWOOD - FIR
PAINT: FLAT BLACK
ENG - DON KEELE

Brüel & Kjær
Copenhagen



Measuring Object: "W" Bass Horn with

K151 4" 18" DRIVER 1 W/1 m

(Tuned to 35 Hz (60)) (2.0V RMS)

Rec. Nr.: _____

Date: Mar 27, 78

Signature: D. Keelo

Rectifier: 2.0V RMS

Zero Level: _____

Lower Lim. Frequency: 10 Hz

Potentiometer Range: 40 dB

Writing Speed: 80 mm/sec.

Paper Speed: 3 mm/sec.

QP 1125

10x
3.16

Brüel & Kjær

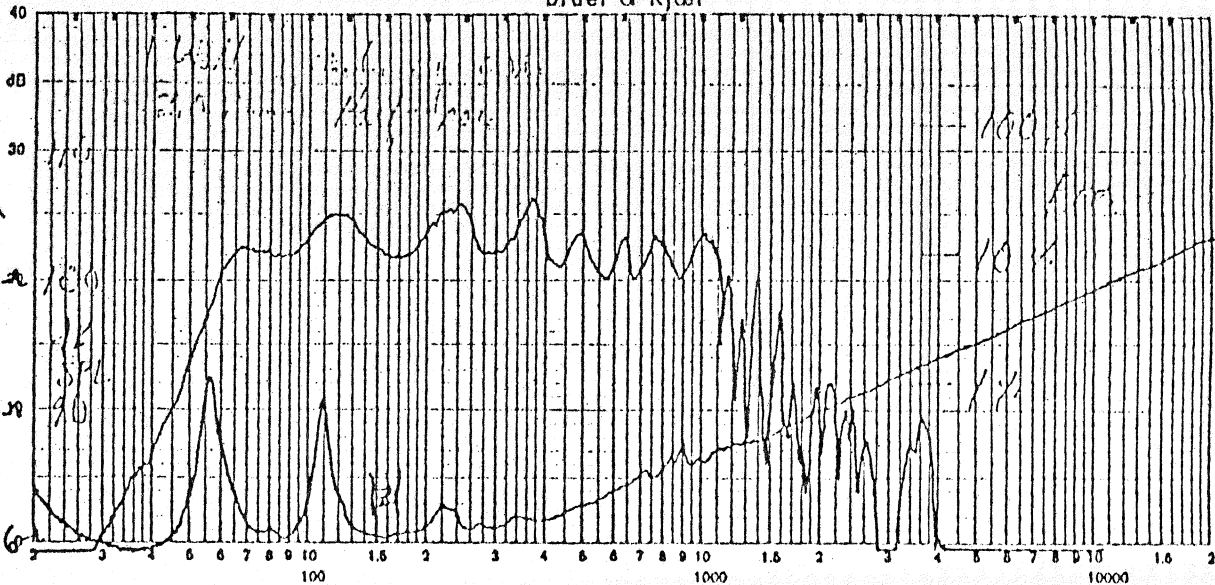

Brüel & Kjær
Copenhagen

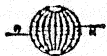

Measuring Object: "W" Bass Horn

K151 4" 18" DRIVER

Rec. Nr.: _____

Date: Mar 27, 78

Signature: D. Keelo

Rectifier: RAS

Zero Level: _____

Lower Lim. Frequency: _____ Hz

Potentiometer Range: 40 dB

Writing Speed: 80 mm/sec.

Paper Speed: 3 mm/sec.

QP 1125

Hz

Brüel & Kjær

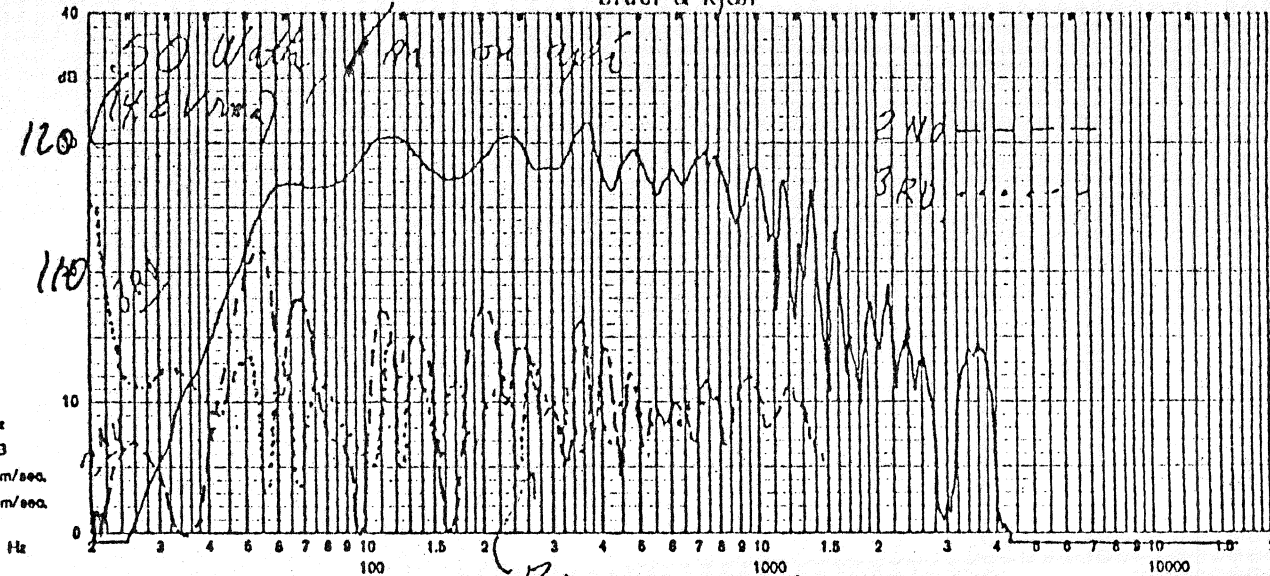

RAISED: 20 dB