

harman consumer group

Engineering Design
Specification

Date

6/12/2012

Rev #

X3

Document Number

9900595

JBL S3900

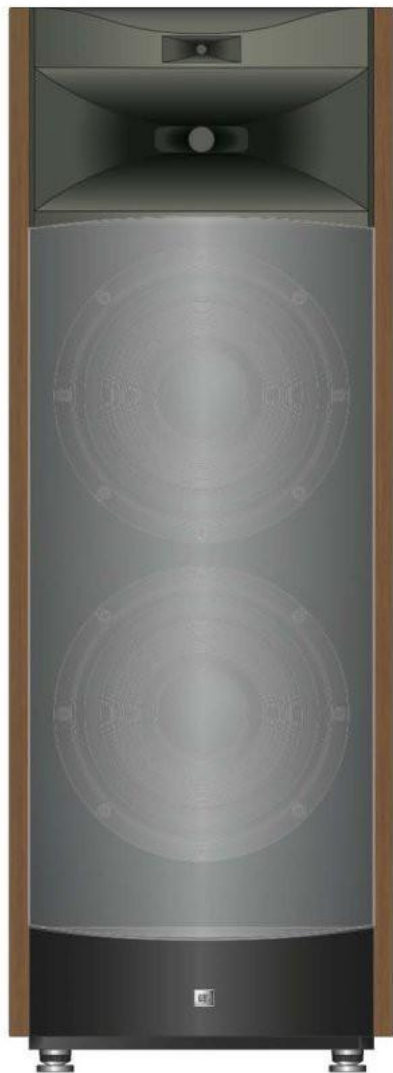

JBL S3900

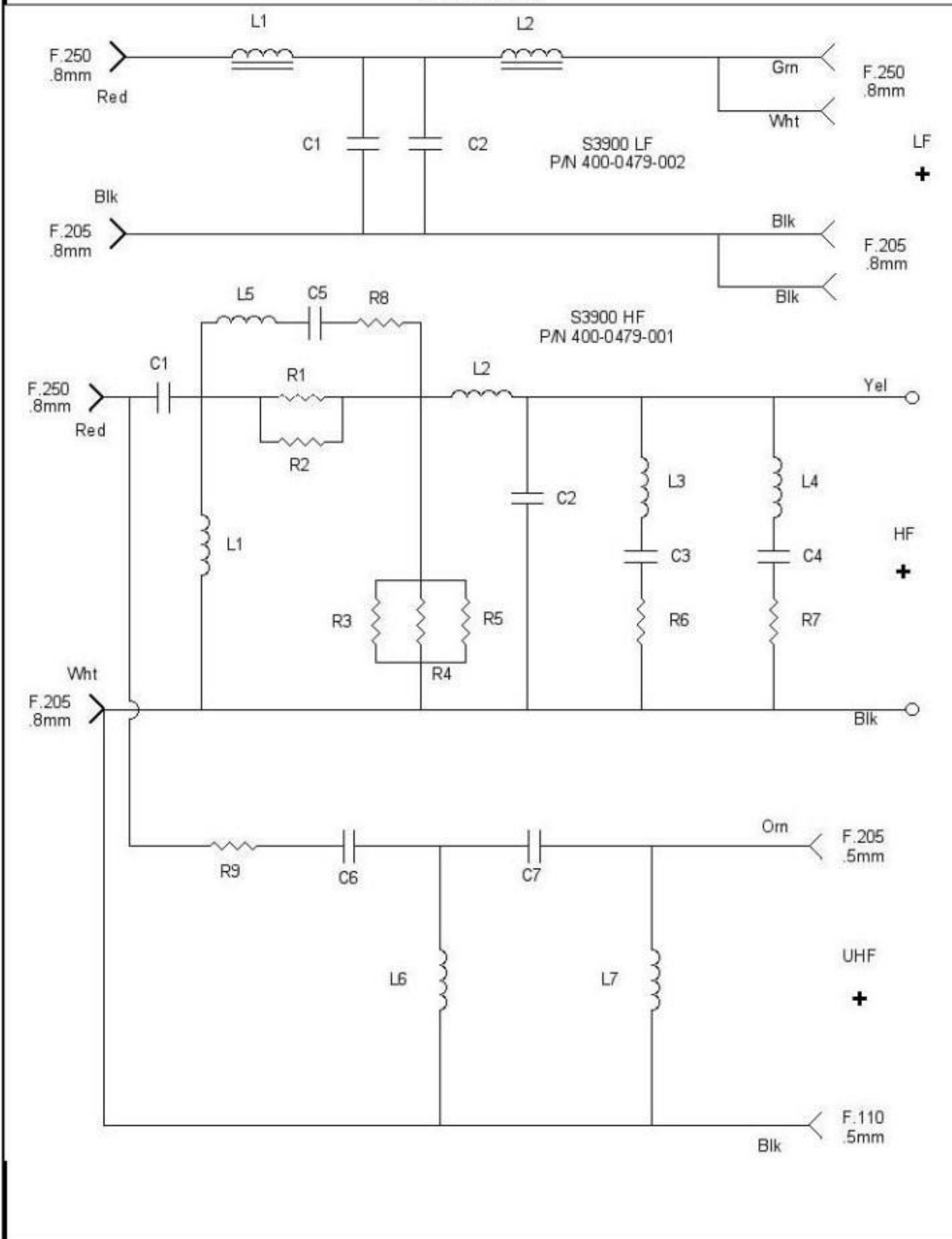

JBL S3900

Voltage vs Freq

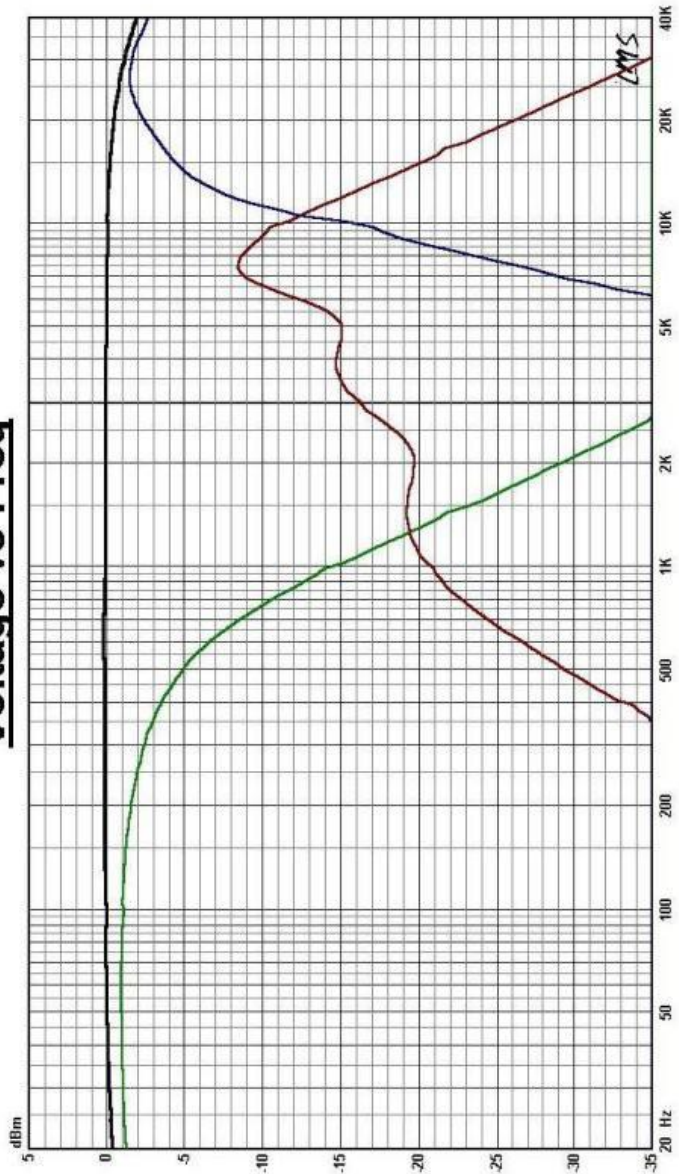

- 4: Ref
- 5: LF, Bosonic
- 6: HF, Bosonic
- 7: UHF, Bosonic

Map

Notes

LINEAR
S / S T M S

Mar 21, 2012
Wed 1:04 pm

Project:
File: S3900.lib

Person:
Company:

4.6.0.371
May 23/2007

LMS

harman consumer group

Engineering Design
Specification

Date
10/19/2012

Rev #
B

Document Number
9990037

10 inch woofer, Special Paper Pulp with SBR Foamed Rubber Surround

Model Number: 100FE-12

Part Number: 320-0048-001

Division: Harman Lifestyle

Where Used: JBL S3900

Approved Supplier(s): GSEC

Design Engineer: Jmoro

Assembled View:



Engineering Design
Specification

Date
10/18/2012

Rev #
A

Document Number
9990037

10 inch woofer, Special Paper Pulp with SBR Foamed Rubber Surround

Section View

Model #

100FE-12

Part #

320-0048-001

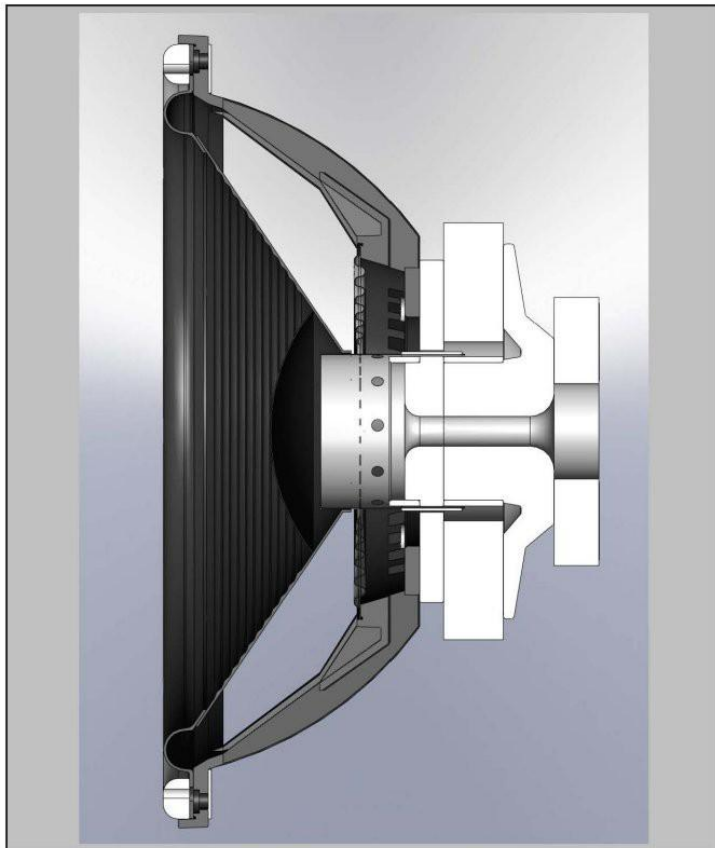

Engineering Design
Specification

Date
10/18/2012

Rev #
A

Document Number
9990037

10 inch woofer, Special Paper Pulp with SBR Foamed Rubber Surround

Document Revision History

Rev #	Date	Description of Change	ECO#	Approval	
				M.E.	T.E.
X1	6/21/2012			n/a	JM
X2	10/18/2012	Update specs		N/A	JM
A	10/18/2012	Release to production	5846	N/A	JM

Engineering Design Specification

Date
10/18/2012

Rev #
A

Document Number
9990037

10 inch woofer, Special Paper Pulp with SBR Foamed Rubber Surround

Transducer Mechanical Characteristics

Model # Part #

Assembly

Overall Height: Mounting Depth:

Frame

Type: Material:
 Color: Finish:
 O.D.: Mounting Diameter:
 Flange Thickness: Screw Holes & Size:
 Other:

Diaphragm

Material: Shape:
 Color: Finish:
 O.D.: Overall Height:
 Thickness: I.D.:
 Other:

Dust Dome

Material: Shape:
 Color: Finish:
 O.D.: Overall Height:
 Other:

Surround

Material: Shape:
 Color: Thickness:
 Width/Roll Diameter: Overall Height:
 Other:

Spider

Material: Shape:
 Roll Diameter/Width: Overall Height:
 Other:

Front Gasket

Material: Color:

Rear Gasket

Material: Color:

Engineering Design
Specification

Date
10/18/2012

Rev #
A

Document Number
9990037

10 inch woofer, Special Paper Pulp with SBR Foamed Rubber Surround

Transducer Mechanical Characteristics (Motor)

Model # Part #

Voice Coil

I.D.: Max O.D.:
 Wire Type: Wire Size:
 Wire Turns: Wire D.C.R.:
 Winding Width: Winding Layers:
 Former: Wrapper:
 Other:

Top Plate

Material: Thickness:
 O.D.: I.D.:
 Plating Type.: Color / Finish:
 Other:

Magnet

Material: Thickness:
 O.D.: I.D.:
 Other:

Pole Piece

Material: O.D.:
 Vent:
 Overhang: Copper Cap:
 Plating Type.: Color / Finish:
 Other:

Back Plate

Material: Thickness:
 O.D.: Features:
 Vent:
 Plating Type.: Color / Finish:
 Other:

Bucking Magnet

Material: Thickness:
 O.D.: I.D.:
 Other:

Engineering Design
Specification

Date
10/18/2012

Rev #
A

Document Number
9990037

10 inch woofer, Special Paper Pulp with SBR Foamed Rubber Surround

Transducer Mechanical Characteristics (Misc. & Notes)

Model # Part #

Shielding Can

Material: Thickness:

Plating Type: Color / Finish:

Other:

Misc

SFG Configuration:

Tinsel Lead Type:

Flux Stabilizing Ring:

Tinsel Lead Attach:

Lug Size: Polarity:

Other:

Notes:

Engineering Design
Specification

Date

10/18/2012

Rev #

A

Document Number

9990037

10 inch woofer, Special Paper Pulp with SBR Foamed Rubber Surround

Model # 100FE-12

Part # 320-0048-001

Transducer Electro-Mechanical Parameters

Fundamental Resonant Frequency (Hz):	Fs	33	+/-	10%
Transducer Direct Current Resistance (Ohms):	DCR	12.5	+/-	3%
Total Driver Q at Fs, Considering all driver Resistance:	Qts	0.39	+/-	5%
Moving Mass (g):	Mms	38	+/-	5%
Motor Strength (T*m):	Bl	16	+/-	5%
Voltage Sensitivity(2.83V@1 meter)	SPL	87.5dB *	+/-	1dB
Radiation Area	Sd	337.0 sq.cm.		

Method

Software: Smith & Larson Audio Woofer Tester

Mass Loading: 50 grams

Misc.: * SPL shown is averaged at 200, 300, 400Hz

Magnetic Flux Information (For Engineering Reference Only)

Total flux lines intercepted by coil windings [Maxwell Turns]:	204,902
Conversion to flux density [Tesla]:	0.617
Flux lines throughout gap thickness [Maxwell Turns]:	136,400
Conversion to flux density [Tesla]:	1.036

Notes

Parameters provided are nominal values which are closest to the Engineering Reference Standard

Voltage Sensitivity takes precedence over possible T/S combinations that would produce SPL

Magnetic Flux data measured with a 2.030 inch diameter, One-turn Search coil

Engineering Design Specification

Date
10/18/2012

Rev #
A

Document Number
9990037

10 inch woofer, Special Paper Pulp with SBR Foamed Rubber Surround

Transducer Test Specifications

production testing quantities per HCG QA AQL

Model # Part #

Polarity Test

Polarity:

Dynamic Test

Sine Sweep Voltage:

Frequency Range:

Sweep Duration:

Power Test

Signal:

Duration:

Impedance

DC Resistance:

Min. Impedance @ Frequency:

Frequency Response

Freq. Response:

Window	Averaging	Slope
57 - 202 Hz, +1.5dB / -1.5dB	1/3 Octave	36 dB / Octave
226 - 640 Hz, +1.0dB / -1.0dB	1/3 Octave	36 dB / Octave
718 - 2000 Hz, +2.0dB / -2.0dB	1/3 Octave	36 dB / Octave
	1/3 Octave	36 dB / Octave
	1/3 Octave	36 dB / Octave
	1/3 Octave	36 dB / Octave
	1/3 Octave	36 dB / Octave
	1/3 Octave	36 dB / Octave
	1/3 Octave	36 dB / Octave
	1/3 Octave	36 dB / Octave

Notes:

Power Test voltage shown indicates 100 hour continuous operation without issue after testing.

**Production Audit power test (6 pcs each run) to same specification but only 2 hour duration.

10 inch woofer, Special Paper Pulp with SBR Foamed Rubber Surround

Model #

100FE-12

Part #

320-0048-001

100FE-12 DV(BMA)#15.1log

100FE-12 DV(BMA)#15

Ver 5.00

Completed: Fri Apr 27 07:45:00 2012

Drive level 40.000 % [1.404 mA]

Sine,LoZP(LV/LA)->Vas,22 pts

```

;
Re      = 12.6431 ohms
Fs      = 33.6039 Hz
Zmax    = 355.8092 ohms
Qes     = 0.3957
Qms     = 10.7404
Qts     = 0.3816
Le      = 0.8244 mH (at 1 kHz)
Diam    = 207.1429 mm ( 8.1552 in )
Sd      =33700.0079 mm^2( 52.2351 in^2)
Vas     = 95.4403 L ( 3.3704 ft^3)
BL      = 15.9938 N/A
Mms     = 37.9187 g
Cms     = 591.5717 uM/N
Kms     = 1690.4121 N/M
Rms     = 0.7454 R mechanical
Efficiency = 0.8600 %
Sensitivity= 91.3628 dB @1w/1m
Sensitivity= 89.3752 dB @2.83Vrms/1m
Krm     = 11.191E-03 ohms Freq dependent resistance
Erm     = 663.789E-03 Rem=Krm*(2*pi*f)^Erm
Kxm     = 17.843E-03 Henries Freq dependent reactance
Exm     = 689.324E-03 Xem=Kxm*(2*pi*f)^Exm
;
Fttest  = 22.069 Hz
Ftest/Fms = 0.6567
Test Mass used = 50.0000 g (Equal to 10.0 nickels)
Test Mass (Ft=Fms*0.90) = 8.895 g (Add -41.105g for Ft=30.244)
Test Mass (Ft=Fms*0.75) = 29.492 g (Add -20.508g for Ft=25.203)

```

Engineering Standard
Frequency Response

Date
10/18/2012

Rev #
A

Document Number
9990037

10 inch woofer, Special Paper Pulp with SBR Foamed Rubber Surround

Model # Part #

SPL vs Freq

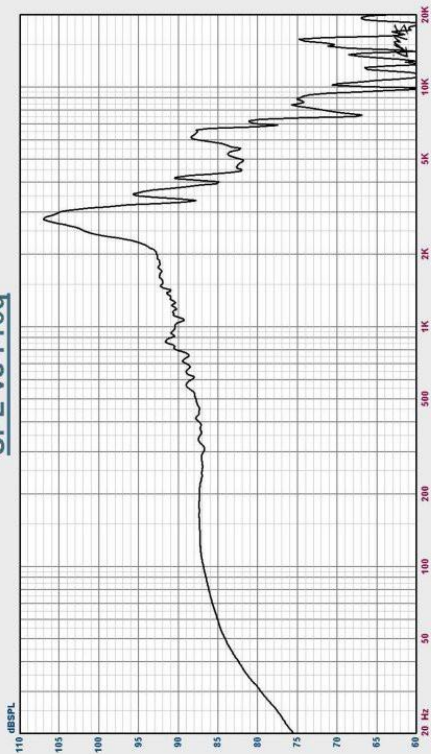

70: 100FE-12 DV(BMA)#(2.8V)_Fund

pin.320-0048-001 DV Units
Measured in Half Space Anechoic Chamber at LM

Map
Notes

LMS 4.5.0.371
May/28/2007

Person:
Company:

Project:
File: 100FE-12.lib

Jun 20, 2012
Wed 4:39 pm

LINEAR
S Y S T E M S

Engineering Standard
Distortion (Low Level)

Date
10/18/2012

Rev #
A

Document Number
9990037

10 inch woofer, Special Paper Pulp with SBR Foamed Rubber Surround

Model # 100FE-12

Part # 320-0048-001

SPL vs Freq

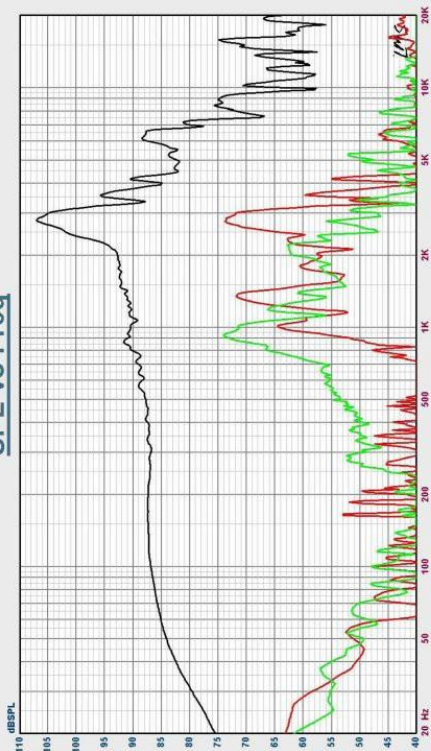

70: 100FE-12 DV(BMA)#9/2.SV1_Fund
71: 100FE-12 DV(BMA)#9/2.SV1_D2+20dB
72: 100FE-12 DV(BMA)#9/2.SV1_D3+20dB

pin.320-0048-001.DV.Units
Measured in Half-Space Acoustic Chamber at LM
Distortion Refered 20dB relative to Fundamental Curve

Map

Notes

LMS 4.5.0.371
May/28/2007

Person:
Company:

Project:
File: 100FE-12.lib

Jun 20, 2012
Wed 4:41 pm

LINEAR
S Y S T E M S

Engineering Standard
Distortion (High Level)

Date
10/18/2012

Rev #
A

Document Number
9990037

10 inch woofer, Special Paper Pulp with SBR Foamed Rubber Surround

Model # Part #

SPL vs Freq

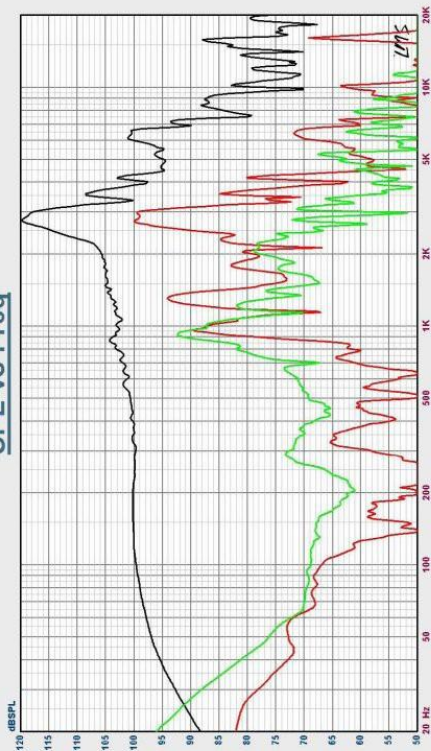

73: 100FE-12 DV(BMAA#K13.DV)_Fund
74: 100FE-12 DV(BMAA#K13.DV)_D2+20dB
75: 100FE-12 DV(BMAA#K13.DV)_D3+20dB

sh.320-0048-001.DV.units
Measured in Half-Space Anechoic Chamber at LM
Distortion Refered 20dB relative to Fundamental Curve

Person:
Company:

Project:
File: 100FE-12.lib

Jun 20, 2012
Wed 4:43 pm

LINEAR
S
Y
T
N

4.4.0.371
May/28/2007

LMS

Engineering Standard
Impedance

Date
10/18/2012

Rev #
A

Document Number
9990037

10 inch woofer, Special Paper Pulp with SBR Foamed Rubber Surround

Model # 100FE-12

Part # 320-0048-001

Impedance vs Freq

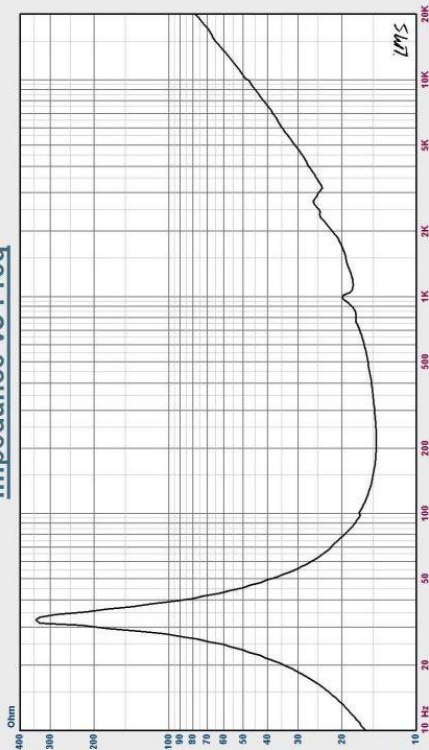

— 34: 100FE-12 DV (BMA) #9

sim.320-0048-001.DV.units

Map

Notes

LMS 4.5.0.371
May/28/2007

Person:
Company:

Project:
File:100FE-12.lib

Jun 20, 2012
Wed 4:33 pm

L I N E A R X
S Y S T E M S

10 inch woofer, Special Paper Pulp with SBR Foamed Rubber Surround

Model # 100FE-12

Part # 320-0048-001

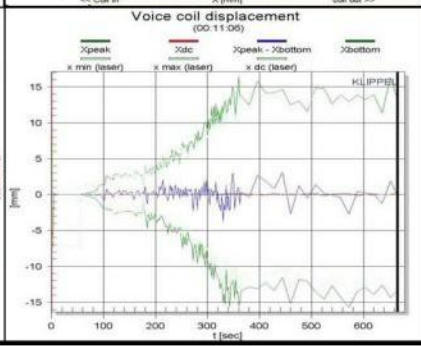
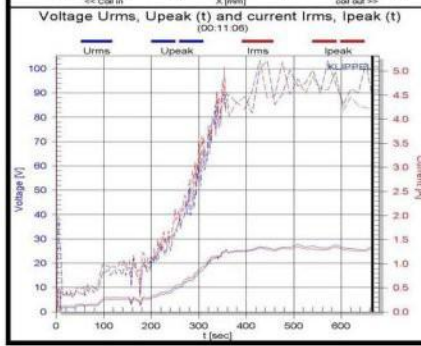
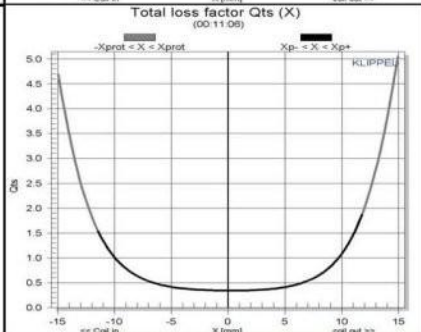
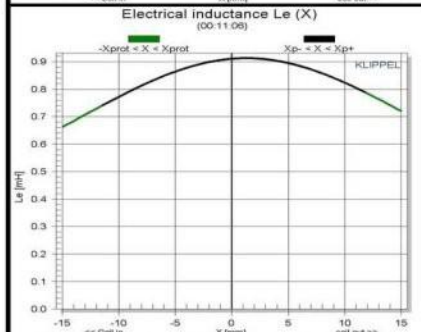

Engineering Design Specification

Date

10/18/2012

Rev #

A

Document Number

9990037

10 inch woofer, Special Paper Pulp with SBR Foamed Rubber Surround

Model #

100FE-12

Part #

320-0048-001

Increase of voice coil temperature $\Delta T_v(t)$ and electrical input power $P(t)$ (00:11:06)

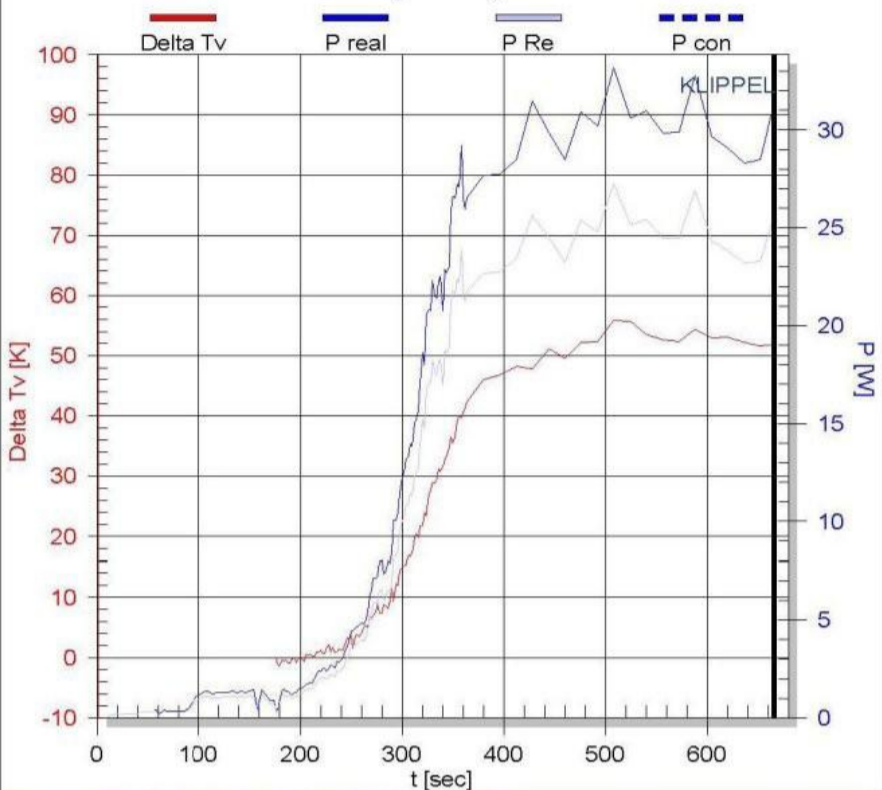

Symbol	Large + Warm	Large + Cold	Small Signal	Unit	Comment
$\Delta T_v = T_v - T_a$	52	0	-0	K	increase of voice coil temperature during the measurement
x_{prot}	15.0	15.0	2.7	mm	maximal voice coil excursion (limited by protection system)
$R_e(T_v)$	14.69	12.22	12.22	Ohm	(imported) voice coil resistance considering increase of voice coil temperature T_v
$L_e(X=0)$	0.91	0.91	0.87	mH	voice coil inductance at the rest position of the voice coil
$L_2(X=0)$	0.63	0.63	0.60	mH	para-inductance at the rest position due to the effect of eddy current
$R_2(X=0)$	4.14	4.14	3.94	Ohm	resistance at the rest position due to eddy currents
$C_{mes}(X=0)$	246	246	204	μF	electrical capacitance representing moving mass
$L_{ces}(X=0)$	182.21	182.21	158.81	mH	electrical inductance at the rest position representing driver compliance
$R_{es}(X=0)$	226.44	226.44	210.13	Ohm	resistance at the rest position due to mechanical losses
$Q_{ms}(X=0, T_v)$	8.32	8.32	7.53		mechanical Q-factor considering R_{ms} only
$Q_{es}(T_v)$	0.35	0.29	0.35		electrical Q-factor considering $R_e(T_v)$ only
$Q_{ts}(X=0, T_v)$	0.34	0.28	0.33		total Q-factor considering $R_e(T_v)$ and R_{ms} only
f_s	23.8	23.8	28.0	Hz	driver resonance frequency
M_{ms}	38.440	38.440	38.440	g	(imported) mechanical mass of driver diaphragm assembly including voice-coil and air load
$R_{ms}(X=0)$	0.689	0.689	0.898	kg/s	mechanical resistance of total-driver losses
$C_{ms}(X=0)$	1.17	1.17	0.84	mm/N	mechanical compliance of driver suspension at the rest position
$Bl(X=0)$	15.45	15.45	15.45	N/A	(imported) force factor at the rest position (Bl product)
V_{as}	186.8939	186.8939	134.8179	l	equivalent air volume of suspension
η_0	0.680	0.818	0.818	%	reference efficiency (2Pi-sr radiation using R_e)
L_m	90.5	91.3	91.3	dB	characteristic sound pressure level
S_d	337.00	337.00	337.00	cm ²	diaphragm area

Symbol	Value	Unit	Comment
Mode	Nonlinear Mode S(7)		
Record	179/179		
Laser	signal reliable		
t	00:11:06	h:min:s	measurement time
Warning	high amplifier error		
$E_i(t)$	6.0	%	error current measurement
$E_x(t)$	2.7	%	error laser measurement
$E_u(t)$	51.1	%	error amplifier check
$\Delta T_v(\Delta T_{lim})$	51.9 (80.0)	K	increase of voice coil temperature (limit)
$Bl_{min}(Bl_{lim})$	30.4 (25.0)	%	minimal force factor ratio (limit)
$C_{min}(C_{lim})$	28.9 (20.0)	%	minimal compliance ratio (limit)
$P(Plim)$	31.46 (30.00)	W	real electrical input power (limit)
L_{min}	73.8	%	minimal inductance ratio
P_n	52.20	W	nominal electrical input power
P_{Re}	25.73	W	Power heating voice coil
P_{con}		W	deducted power due to convection cooling
$G_{arge}(G_{max})$	17.2 (26.0)	dB	gain of the excitation amplitude increased in the large signal domain (maximum)
Mech. system		abs.	import used to identify mechanical system in absolute quantities
x_{dc}	0.3	mm	dc component of voice coil excursion measured in the last update interval
x_{peak}	13.2	mm	positive peak value of voice coil excursion measured in the last update interval
x_{bottom}	-13.3	mm	negative peak value (bottom) of voice coil excursion measured in the last update interval
x_{p+}	11.8	mm	upper limit of displacement range (99% probability)
x_{p-}	-11.4	mm	lower limit of displacement range (99% probability)
x_{prot}	15.0	mm	maximal voice coil excursion allowed by protection system
v_{rms}	0.73	m/s	voice coil velocity
I_{rms}	1.323	A	rms value of the electrical input current
U_{rms}	27.035	V	rms value of the electrical voltage at the transducer terminals
I_{peak}	4.223	A	peak value of the electrical input current
U_{peak}	87.309	V	peak value of the electrical voltage at the transducer terminals
PC	1.60	dB	thermal power compression factor
D_b	36.8	%	distortion factors representing contribution of nonlinear force factor
D_l	1.8	%	distortion factor representing contribution of nonlinear inductance
D_c	31.4	%	distortion factor representing contribution of nonlinear compliance
$R_{tc}(v)$		K/W	
$R_{th total}$	2.02	K/W	$\Delta T_v / P_{Re}$