

# CS-1100A

(100MHz DUAL TRACE OSCILLOSCOPE)

## INSTRUCTION MANUAL



# SAFETY

## Symbol in This Manual

 This symbol indicates where applicable cautionary or other information is to be found.

## Power Source

This equipment operates from a power source that does not apply more than 250 V rms between the supply conductors or between either supply conductor and ground. A protective ground connection by way of the grounding conductor in the power cord is essential for safe operation.

## Grounding the Product

This equipment is grounded through the grounding conductor of the power cord. To avoid electrical shock, plug the power cord into a properly wired receptacle before connecting to the equipment input or output terminals.

## Use the Proper Power Cord

Use only the power cord and connector specified for your product.

## Use the Proper Fuse

To avoid fire hazard, use a fuse of the correct type.

## Do not Operate in Explosive Atmospheres

To avoid explosion, do not operate this product in an explosive atmosphere.

## Do not Remove Cover or Panel

To avoid personal injury, do not remove the cover or panel. Refer servicing to qualified personnel.

# CONTENTS

SAFETY .....	2	PULSE WIDTH MEASUREMENTS .....	20
FEATURES .....	3	PULSE RISETIME AND FALLTIME	
SPECIFICATIONS .....	4	MEASUREMENTS .....	20
PREPARATION FOR USE .....	6	TIME DIFFERENCE MEASUREMENTS .....	21
CONTROLS AND INDICATORS .....	8	PHASE DIFFERENCE MEASUREMENTS .....	22
FRONT PANEL .....	8	RELATIVE MEASUREMENTS .....	22
REAR PANEL .....	12	PULSE JITTER MEASUREMENT .....	24
OPERATION .....	13	SWEEP MULTIPLICATION (MAGNIFICATION) .....	24
INITIAL STARTING PROCEDURE .....	13	DELAYED SWEEP TIME MEASUREMENT .....	25
(1) NORMAL SWEEP DISPLAY OPERATION .....	13	PULSE WIDTH MEASUREMENTS USING	
(2) MAGNIFIED SWEEP OPERATION .....	15	DELAYED SWEEP .....	26
(3) DELAYED SWEEP OPERATION		FREQUENCY MEASUREMENTS USING	
(ALTERNATING SWEEP OPERATION) .....	15	DELAYED SWEEP .....	26
(4) X-Y OPERATION .....	16	PULSE REPETITION TIME .....	27
(5) VIDEO SIGNAL OBSERVATION .....	16	USING DELAYED SWEEP FOR MEASUREMENTS OF	
(6) SINGLE SWEEP OPERATION .....	16	RISETIMES AND FALLTIMES .....	27
APPLICATION .....	17	TIME DIFFERENCE MEASUREMENTS USING	
PROBE COMPENSATION .....	17	DELAYED SWEEP .....	28
TRACE ROTATION COMPENSATION .....	17	X-Y APPLICATION .....	28
DC VOLTAGE MEASUREMENTS .....	17	ACCESSORIES .....	30
MEASUREMENTS OF THE VOLTAGE			
BETWEEN TWO POINTS ON A WAVEFORM .....	18		
ELIMINATION OF UNDESIRED SIGNAL			
COMPONENTS .....	18		
TIME MEASUREMENTS .....	19		
FREQUENCY MEASUREMENTS .....	19		

## FEATURES

- With 1 mV/div sensitivity and 100 MHz bandwidth (1 mV/div when  $\times 5$  GAIN function is used).
- Fast 20 ns/div sweep speed (2 ns/div with  $\times 10$  magnification).
- Vertical sensitivity error and sweep rate error are  $\pm 3\%$  at 10 – 35°C and accurate measurements are provided.
- The 150 mm rectangular CRT with internal graticule provides high brightness and accurate measurements, free of parallax error and a 16 kV accelerating potential.
- For convenience in making rise time measurements, the 0%, 10%, 90% and 100% levels are marked on the graticule scale of the CRT.
- The built-in auto-focus circuit keeps the waveforms in clear focus automatically regardless of the INTENSITY control setting.
- By SCALE ILLUM control, the waveform is easy observed in darkened area and photograph of the waveform is easy provided a single photograph of the waveform superimposed on the graticule scale.
- Delay sweep mode is available to observe the portion of waveform with magnification as necessary.
- Single sweep permits viewing and photographing one-time events.
- The delay line permits viewing of leading edge of high-frequency, fast risetime pulses.
- The VIDEO synchronization circuit permits to observe video signal easily.
- $\times 10$  magnification, and alternating sweep are provided.
- The 20 MHz bandwidth limiter incorporated eliminates high-frequency, noise and stabilizes signal waveforms displayed.
- The dual intensity control circuit permits to vary intensities separately for A and B sweeps.
- A switching type power supply provides stable operation with varying power source (90 V ~ 264 V).
- Provides with CH1 OUT terminal to monitor input signal of channel 1.
- Selectable Auto-free run function provides sweep without trigger input signal.
- Vertical MODE automatically determines the trigger signal with V. MODE of trigger SOURCE.
- DELAY TIME MULT control permits the accurate time measurements with the dial scale.
- X-Y operation is easy provided by one-touche.

# SPECIFICATIONS

## CRT

Model: 150 mm, rectangular with internal graticule

Acceleration Voltage: 16 kV

Display Area: 8 x 10 div  
(1 div = 10 mm)

## VERTICAL AXIS (CH1 and CH2)

Sensitivity: 5 mV/div to 5 V/div  
(x1 mode)  
1 mV/div to 1 V/div  
(x5 mode)

Accuracy: ±3% (10~35°C)  
±5% (0~50°C)

Attenuator: 10 steps, 5 mV/div to 5 V/div in 1-2-5 sequence.  
Vernier control for fully adjustable sensitivity between steps.

Input Impedance: 1 MΩ ± 2%, approx. 22pF

Frequency Response:  
x1 mode: DC; DC to 100 MHz, -3 dB  
AC; 5 Hz to 100 MHz, -3 dB  
5V/div range and  
x5 mode: DC; DC to 50 MHz, -3 dB  
AC; 5 Hz to 50 MHz, -3 dB

Risetime: 3.5 nsec or less (100 MHz)

Signal Delay Time: Approx. 10 nsec on the CRT screen.

Crosstalk -40 dB minimum

Operating Modes: CH1; single trace  
CH2; single trace  
ADD; CH1 + CH2 added as a single trace.  
ALT; dual trace, alternating  
CHOP; dual trace, chopped

Chop Frequency: Approx. 250 kHz

Channel Polarity: Normal or inverted, channel 2 only inverted.

 Maximum Input Voltage: 500 Vp-p or 250 V (dc + ac peak)

Non-Distorted Maximum Amplitude: More than 8 div (dc to 100 MHz)

Bandwidth Limiting: Vertical system bandwidth with the 20 MHz BW push button switch pushed is approximately 20 MHz

## HORIZONTAL AXIS (Input thru CH2)

Operating Modes: With HORIZ. DISPLAY switch, X-Y operation is selectable  
CH1; Y axis  
CH2; X axis

Sensitivity: Same as vertical axis (CH2)

Accuracy: Same as vertical axis (CH2)

Input Impedance: Same as vertical axis (CH2)

Frequency Response: DC; DC to 5 MHz, -3 dB  
AC; 5 Hz to 5 MHz, -3 dB  
3° or less at 100 kHz

X-Y Phase Difference: 3° or less at 100 kHz

 Maximum Input Voltage: Same as vertical axis (CH2)

## SWEEP

Type: A; A sweep  
ALT; A sweep (intensified for duration of B sweep) and B sweep (delayed sweep) alternating  
B DLYD; Delayed sweep  
X-Y; X-Y oscilloscope

Sweep Time: A; 20 ns/div to 0.5 s/div in 23 ranges, in 1-2-5 sequence.  
Vernier control provides fully adjustable sweep time between steps.  
B; 20 ns/div to 50 ms/div in 20 ranges, in 1-2-5 sequence.

Accuracy: ±3% (10~35°C)  
±6% (0~50°C)

Sweep Magnification: x10 (ten times)  
±5% (10~35°C)  
±7% (0~50°C)

Linearity: ±3% (on 20 ns/div to 0.5 s/div)  
±5% (x10 MAG)

Holdoff: Continuously variable from NORM to more than five times (MAX)

Trace Separation: B sweep can be separated downward from A sweep up to approx. 4 divisions, continuously adjustable.

Delay Method (B MODE): Continuous delay (STARTS AFTER DELAY), Trigger delay (TRIGGER)

Delay Time: From 200 nsec to 0.5 sec.  
Available delay time is 0.2 to 10 times the A sweep time setting, continuously adjustable

Time Difference Measurement Accuracy:  $\pm 2\%$  (10 ~ 35°C)  
 $\pm 4\%$  (0 ~ 50°C)

Delay Jitter: 1/20000 of ten times of A sweep time setting

### TRIGGERING

Trigger Mode: AUTO, NORM, SINGLE

Trigger Source: V, MODE; Trigger selected by vertical MODE switch.

CH1: Triggered by CH1 signal

CH2: Triggered by CH2 signal

EXT: Triggered by external trigger

LINE: Triggered by line voltage

Coupling: AC, LF<sub>REF</sub>, HF<sub>REF</sub>, DC, VIDEO

LINE sync (horizontal sync pulses) automatically selected at A sweep times of 50  $\mu$ s/div to 20 ns/div and FRAME sync (vertical sync pulses) automatically selected at A sweep times of 0.5 s/div to 0.1 ms/div

Polarity: + / -

Trigger Sensitivity

COUPLING	FREQ. RANGE	MINIMUM SYNC AMPLITUDE	
		INT	EXT
DC	DC ~ 50 MHz	1.0 div	100 mV
	DC ~ 100 MHz	1.5 div	210 mV
AC	Same as for DC but with increased minimum level for below 20 Hz.		
AC HF <sub>REF</sub>	Increased minimum level below 20 Hz and above 30 kHz.		
AC LF <sub>REF</sub>	Increased minimum level below 30 kHz.		
VIDEO	FRAME/LINE	0.5 div	50 mV

AUTO: Same as above specifications for above 50 Hz.

External Trigger: Input impedance: 1 M $\Omega$ , approx. 40 pF

 Maximum Input Voltage: 250 V (dc + ac peak)

**CALIBRATING VOLTAGE** 1 V,  $\pm 2\%$ , square wave, positive polarity, 1 kHz,  $\pm 3\%$

### INTENSITY MODULATION

Sensitivity: TTL compatible  
positive voltage decreases brightness,  
negative voltage increases brightness.

Input Impedance: Approx. 10 k $\Omega$

Usable Frequency

Range: DC to 5 MHz

 Maximum Input Voltage: 50 V (dc + ac peak)

### VERTICAL AXIS SIGNAL OUTPUT (CH1 OUT)

Output Voltage: 50 mVp-p/div into 50  $\Omega$

Output Impedance: Approx. 50  $\Omega$

Frequency Response: DC to 100 MHz, -3 dB into 50  $\Omega$  (Unapplied  $\times 5$  GAIN mode)

### POWER REQUIREMENT

Power Supply: 90 V ~ 264 V

Line Frequency: 45 Hz ~ 400 Hz

Power Consumption: Approx. 60 W (into 100 V, 50 Hz)

### DIMENSIONS (W $\times$ H $\times$ D)

304(346)  $\times$  160(173)  $\times$  351(411) mm  
( ) dimensions include protrusion from basic outline dimensions

**WEIGHT:** Approx. 8.8 kg

### ENVIRONMENTAL

Within Specifications: 10°C to 35°C, 85% max. relative humidity

Full Operation: 0°C to 50°C, 90% max. relative humidity

### ACCESSORIES SUPPLIED

Probe: PC-39...2

Instruction Manual: 1

AC Power Cord: 1

■ Circuit and ratings are subject to change without notice due to developments in technology.

# PREPARATION FOR USE

## SAFETY

Before connecting the instrument to a power source, carefully read the following information, then verify that the proper power cord is used and the proper line fuse is installed for power source. If the power cord is not applied for specified voltage, there is always a certain amount of danger from electric shock.

### Line voltage

This instrument operates using ac-power input voltages that 90 V to 264 V at frequencies from 45 Hz to 400 Hz.

### Power cord

The ground wire of the 3-wire ac power plug places the chassis and housing of the oscilloscope at earth ground. Do not attempt to defeat the ground wire connection or float the oscilloscope; to do so may pose a great safety hazard. The appropriate power cord is supplied by an option that is specified when the instrument is ordered.

The optional power cords are shown as follows in Fig. 1.





### Line fuse

The fuse holder is located on the rear panel and contains the line fuse. Verify that the proper fuse is installed by replacing the line fuse.

## EQUIPMENT PROTECTION

1. Never allow a small spot of high brilliance to remain stationary on the screen for more than a few seconds. The screen may become permanently burned. A spot will occur only when the scope is set up for X-Y operation and no signal is applied. Either reduce the intensity so the spot is barely visible, switch back to normal sweep operation when no signal is applied, or set up the scope for spot blanking.
2. Never cover the ventilating holes on the top of the oscilloscope, as this will increase the operating temperature inside the case.
3. Never apply more than the maximum rating to the oscilloscope inputs.  
CH1, CH2 INPUT jacks: 500 Vp-p or 250 V (dc+ac peak)  
EXT TRIG INPUT jack: 250 V (dc+ac peak)  
Z axis INPUT jack: 50 V (dc+ac peak)  
Never apply external voltage to the oscilloscope output terminals.
4. Always connect a cable from the earth ground (GND) jack of the oscilloscope to the chassis of the equipment under test. Without this caution, the entire current for the equipment under test may be drawn through the probe clip leads under certain circumstances. Such conditions could also pose a safety hazard, which the ground cable will prevent.

5. Always use the probe ground clips for best results. Do not use an external ground wire in lieu of the probe ground clips, as undesired signals may be introduced.
6. Operation adjacent to equipment which produces strong ac magnetic fields should be avoided where possible. This includes such devices as large power supplies, transformers, electric motors, etc., that are often found in an industrial environment. Strong magnetic shields can exceed the practical CRT magnetic shielding limits and result interference and distortion.
7. Probe compensation adjustment matches the probe to the input of the scope. For best results, compensation of probe should be adjusted initially, then the same probe always used with the input of scope. Probe compensation should be readjusted whenever a probe from a different scope is used.

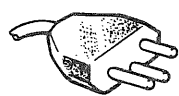
Plug configuration	Power cord and plug type	Factory installed instrument fuse	Line cord plug fuse	Parts No. for power cord
	North American 120 volt/60 Hz Rated 15 amp (12 amp max; NEC)	1.2 A, 250 V Fast blow AGC/3AG	None	E30-1820-05
	Universal Europe 220 volt/50 Hz Rated 16 amp	1.2 A, 250 V Fast blow 5 x 20 mm	None	E30-1819-05
	U.K. 240 volt/50 Hz Rated 13 amp	1.2 A, 250 V Fast blow 5 x 20 mm	1.2 A Type C	
	Australian 240 volt/50 Hz Rated 10 amp	1.2 A, 250 V Fast blow 5 x 20 mm	None	E30-1821-05
	North American 240 volt/60 Hz Rated 15 amp (12 amp max; NEC)	1.2 A, 250 V Fast blow AGC/3AG	None	
	Switzerland 240 volt/50 Hz Rated 10 amp	1.2 A, 250 V Fast blow AGC/3AG 5 x 20 mm	None	

**Fig. 1 Power Input Voltage Configuration**

# CONTROLS AND INDICATORS

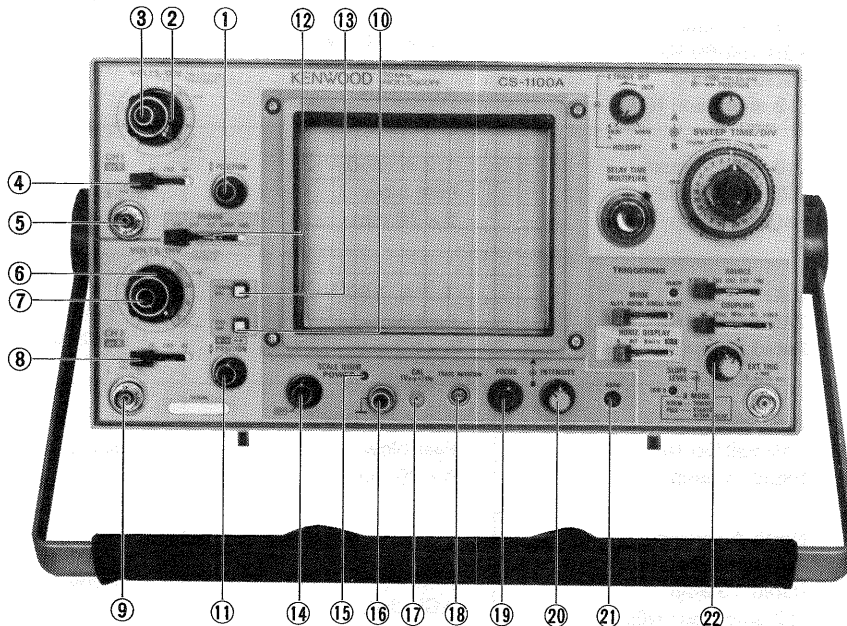

Fig. 2

## FRONT PANEL

### ① $\updownarrow$ POSITION Control

Rotation adjusts vertical position of channel 1 trace. In X-Y operation, rotation adjusts vertical position of display.

### ② VOLTS/DIV Control

Vertical attenuator for channel 1; provides step adjustment of vertical sensitivity. When VARIABLE control ③ is set to CAL, vertical sensitivity is calibrated in 10 steps from 5 V/div to 5 mV/div.

For X-Y operation, this control provides step adjustment of vertical sensitivity.

### ③ VARIABLE, PULL $\times 5$ GAIN Controls

#### VARIABLE:

Rotation provides fine control of channel 1 vertical sensitivity. In the fully clockwise (CAL) position, the vertical attenuator is calibrated. For X-Y operation, this control serves as the Y axis attenuation fine adjustment.

#### PULL $\times 5$ GAIN:

When pulled out, the VOLTS/DIV setting is multiplied by five and for X-Y operation, the Y-axis sensitivity is multiplied accordingly. In  $\times 5$  GAIN mode, the vertical gain is increased and the trace becomes thickness.

### ④ AC-GND-DC Switch

Three-position lever switch which operates as follows:

AC: Blocks dc component of channel 1 input signal.

GND: Opens signal path and grounds input to vertical amplifier. This provides a zero-signal base line, the position of which can be used as a reference when performing dc measurements.

DC: Direct input of ac and dc component of channel 1 input signal.

### ⑤ INPUT Jack

Vertical input for channel 1 trace. Vertical input for X-Y operation.

### ⑥ VOLTS/DIV Control

Vertical attenuator for channel 2; provides step adjustment of vertical sensitivity. When VARIABLE control ⑦ is set to CAL, vertical sensitivity is calibrated in 10 steps from 5 V/div to 5 mV/div.

In X-Y operation, this control provides step adjustment of horizontal sensitivity.



## ⑦ VARIABLE, PULL × 5 GAIN Controls

### VARIABLE:

Rotation provides fine control of channel 2 vertical sensitivity. In the fully clockwise (CAL) position, the vertical attenuator is calibrated. In X-Y operation, this control becomes the fine horizontal gain control.

### PULL × 5 GAIN:

When pulled out, the VOLTS/DIV setting is multiplied by five and for X-Y operation the X-axis sensitivity is multiplied accordingly. In ×5 GAIN mode, the vertical gain is increased and the trace becomes thickness.

## ⑧ AC-GND-DC Switch

Three-position lever switch which operates as follows:

AC: Blocks dc component of channel 2 input signal.

GND: Opens signal path and grounds input to vertical amplifier. This provides a zero-signal base line, the position of which can be used as a reference when performing dc measurements.

DC: Direct input of ac and dc component of channel 2 input signal.

## ⑨ INPUT Jack

Vertical input for channel 2 trace in normal sweep operation. External horizontal input in X-Y operation.

## ⑩ CH2 INV Push-button Switch

In the NORM position (button released), the channel 2 signal is non-inverted. In the INV position (button engaged), the channel 2 signal is inverted.

## ⑪ POSITION, X-Y Control

Rotation adjusts vertical position of channel 2 trace.

In X-Y operation adjusts horizontal position of display.

## ⑫ MODE Switch

Five-position lever switch which selects the basic operating modes of the oscilloscope.

CH1: Only the input signal to channel 1 is displayed as a single trace.

CH2: Only the input signal to channel 2 is displayed as a single trace.

ALT: Alternate sweep is selected regardless of sweep time as dual trace (CH1 and CH2).

CHOP: Chop sweep is selected regardless of sweep time at approximately 250 kHz as dual trace (CH1 and CH2).

ADD: The waveforms from channel 1 and channel 2 input signals are added and the sum is displayed as a single trace. When the CH2 INV

⑩ button is engaged, the waveform from channel 2 is subtracted from the channel 1 waveform and the difference is displayed as a single trace.

## NOTE:

The various vertical mode settings are related to horizontal mode and trigger source. See the section on HORIZ DISPLAY and SOURCE for a description of this relationship.

## ⑬ 20 MHz BW Push-button Switch

Limits the vertical bandwidth to approximately 20 MHz when engaged this button.

## ⑭ POWER, SCALE ILLUM Controls

Fully counterclockwise rotation of this control (OFF position) turns off oscilloscope. Clockwise rotation turns on oscilloscope. Further clockwise rotation of the control increases the illumination level of scale.

## ⑮ PILOT Lamp

Lights when oscilloscope is turned on.

## ⑯ GND terminal/binding post.

Earth and chassis ground.

## ⑰ CAL, 1 Vp-p, $\approx$ 1 kHz Terminal

Provides 1 kHz, 1 Volt peak-to-peak square wave signal. This is useful for probe compensation adjustment.

## ⑱ TRACE ROTATION Control

Electrically rotates trace to horizontal position.

Strong magnetic fields may cause the trace to be tilted.

The degree of tilt may vary as the scope is moved from one location to another. In these cases, adjust this control.

## ⑲ FOCUS Control

Adjusts the trace for optimum focus.

## ⑳ A INTENSITY, B INTENSITY Controls

Allows adjustment of intensity for the A sweep and B sweep respectively.

### A INTENSITY:

Adjusts the trace intensity for A sweep and the display intensity for X-Y operation.

### B INTENSITY:

Adjusts the intensity of the B sweep.

## ㉑ ASTIG Control

Astigmatism adjustment provides optimum spot roundness when used in conjunction with FOCUS control regardless intensity control.

## ㉒ LEVEL Control

Trigger level adjustment determines point on waveform where sweep starts.

When COUPLING switch is selected in VIDEO, the trigger level adjustment has no effect.

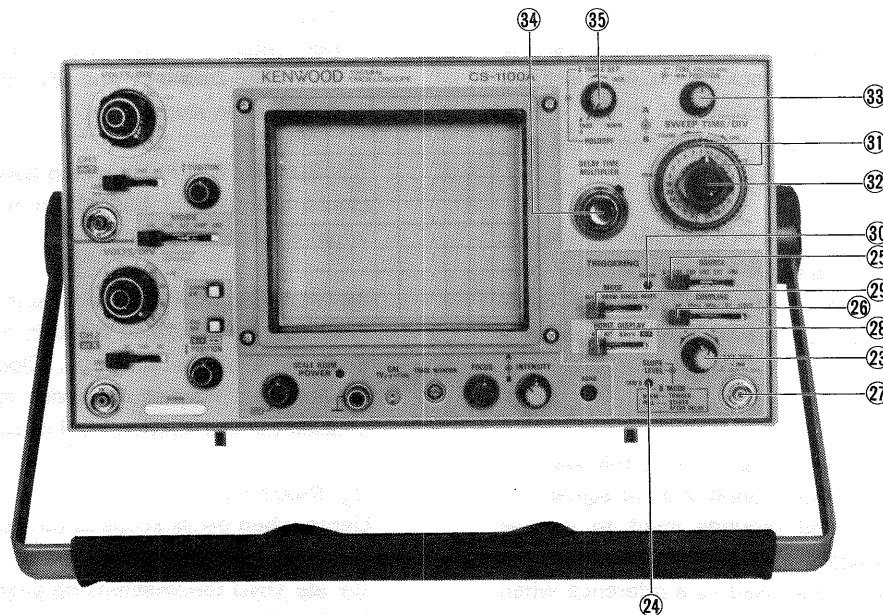

Fig. 3

**23 SLOPE Control, B MODE Switch**

Used to select delay sweep mode by SLOPE switch.

**SLOPE:** Selects positive going (+) or negative going (-).  
 + equals most positive point of triggering and  
 - equals most negative point of triggering.

**B MODE:**

**PULL-STARTS AFTER DELAY**

B sweep is triggered immediately after the delay set by A SWEEP TIME/DIV and DELAY TIME MULT controls.

**NORM-TRIGGER**

B sweep starts immediately after the delay time selected by the DELAY TIME MULT and SWEEP TIME/DIV controls. Even when this switch is in NORM position with the trigger MODE switch set to AUTO, turning the trigger LEVEL clockwise or counterclockwise release the trigger and set the scope to B STARTS AFTER DELAY operation.

**24 TRIG'D Lamp**

Green LED lights for duration of triggered A sweep; shows when trigger LEVEL control is properly set to obtain triggering.

**25 SOURCE Switch**

Five-position lever switch; selects triggering source for the sweep, with following positions;

**V. MODE:** The trigger source is determined by vertical MODE selection.

**CH1:** Channel 1 signal is used as a trigger source.

**CH2:** Channel 2 signal is used as a trigger source.

**ADD:** The algebraic sum of channel 1 and channel 2 signal is the trigger source. (If CH2 INV engaged, the difference becomes the trigger source.)

**ALT:** Display is alternately triggered by CH1 and CH2.

**CHOP:** The display cannot be synchronized with the input signal since the chopping signal becomes the trigger source.

**CH1:** Sweep is triggered by channel 1 signal regardless of vertical MODE selection.

**CH2:** Sweep is triggered by channel 2 signal regardless of vertical MODE selection.

**EXT:** Sweep is triggered by signal applied to EXT TRIG INPUT jack (27).

**LINE:** Sweep is triggered by line voltage.

**26 COUPLING Switch**

Five-position lever switch; selects coupling for sync trigger signal.

**AC:** Trigger is ac coupled. Blocks dc component of input signal; most commonly used position.

**LF<sub>REF</sub>:** Sync signal is coupled through high-pass filter to eliminate low-frequency components for stable triggering of high frequency signals.

**HF<sub>REF</sub>:** Sync signal is coupled through a low-pass filter to eliminate high-frequency components for stable triggering of low frequency signals.

**DC:** The sync signal is dc coupled for sync which includes the effects of dc components.

**VIDEO:** For synchronization of video signals. The position of the A SWEEP TIME/DIV control determines whether FRAME or LINE is to be syn-

chronized. Setting between 0.5 s and 0.1 ms result in FRAME while those between 50  $\mu$ s and 20 ns result in LINE sync.

**⑳ EXT TRIG Jack**

Input terminal for external trigger signal.

**㉑ HORIZ. DISPLAY Switch**

Four-position lever switch; used to select the horizontal display mode.

**A:** Only A sweep is operative with the B sweep dormant.

**ALT:** A sweep alternates with the B sweep. For this mode of operation, the B sweep appears as an intensified section on the A sweep.

**B DLY'D:** Only delayed B sweep is operative.

**X-Y:** Channel 1 becomes the Y axis and channel 2 becomes the X axis for X-Y operation. The setting of the vertical MODE and trigger MODE switches have no effect.

**㉒ MODE Switch**

Four-position lever switch; selects triggering mode.

**AUTO:** Triggered sweep operation. When trigger signal is present, automatically generates sweep (free runs in absence of trigger signal.)

**NORM:** Normal triggered sweep operation. No trace is presented when a proper trigger signal is not applied.

**SINGLE:** Single sweep operation. Note that in this mode, simultaneous observation of both the A and B sweeps is not possible.

**NOTE:**

For dual trace, single sweep operation, vertical MODE must not be set to ALT. Use the CHOP mode instead.

**RESET:** This is the reset switch for single sweep operation. Switching the RESET side initiates a single sweep which will begin when the next sync trigger occurs.

**㉓ Ready Indicator**

In SINGLE triggering mode, lights when trigger MODE switch is set to RESET and goes off when sweep is completed.

**㉔ A SWEEP TIME/DIV, B SWEEP TIME/DIV Controls**

**A SWEEP TIME/DIV:**

Horizontal coarse A sweep time selector.

Selects calibrated sweep times of 20 ns/div to 0.5 s/div in 23 steps when A VARIABLE control

⑳ is set to CAL position (fully clockwise).

**B SWEEP TIME/DIV:**

Coarse horizontal B sweep time selector.

Selects sweep times of 20 ns/div to 50 ms/div in

20 steps.

B sweep time selector should be set slower than A sweep time.

**㉕ A VARIABLE Control**

Fine A sweep time adjustment. In the fully clockwise (CAL) position, the sweep time is calibrated.

No fine adjustment is available for the B sweep time.

**㉖ ◀▶ POSITION, FINE, PULL  $\times$  10 MAG Controls**

Rotation adjusts horizontal position of trace. For X-Y operation, this controls have no effect.

**◀▶ POSITION:**

Horizontal position coarse adjustment.

**FINE, PULL  $\times$  10 MAG:**

Rotation becomes fine adjustment of horizontal position of trace. When pulled out, ten times sweep expands.

Push-pull switch alternately turns  $\times$  10 MAG off and on (ten times sweep expansion).

**㉗ DELAY TIME MULTIPLIER Control**

Adjusts the start time of the B sweep to some delay time after the start of A sweep. The delay time may be set to values between 0.2 and 10 times the setting of the A SWEEP TIME/DIV control.

**㉘ ▲▼ TRACE SEP, HOLDOFF Controls**

**▲▼ TRACE SEP:** Adjusts vertical separation between A sweep and B sweep (control has effect only in the ALT of HORIZ. DISPLAY).

Counterclockwise rotation increases separation; B sweep moves down with respect to A sweep up to 4 divisions.

**HOLDOFF:** Rotation adjusts holdoff (trigger inhibit period beyond sweep duration).

Counterclockwise rotation increases holdoff period from NORM to max more than five times before the B ENDS A position.

In the B ENDS A position (fully counterclockwise), the A sweep is reset at end of the B sweep. And therefore intensity of B sweep increases to provide the A sweep.

B ENDS A mode is applicable to the ALT, B DLY'D modes of HORIZ DISPLAY.

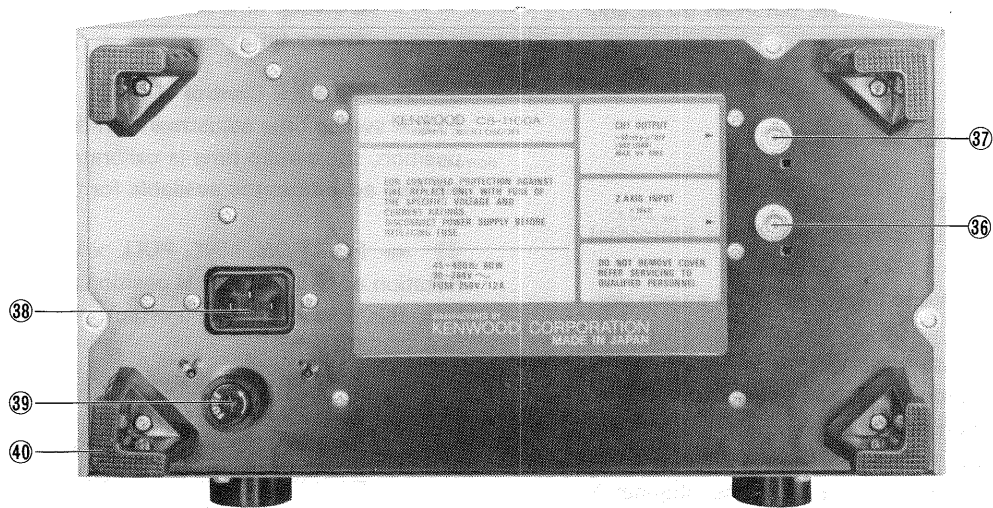

Fig. 4

## REAR PANEL

### ③⑥ Z AXIS INPUT Jack

External intensity modulation input; TTL compatible. Positive voltage decreases brightness, negative voltage increases brightness.

### ③⑦ CH1 OUTPUT Jack

CH1 vertical output signal connector. This connector is used to measure the frequency by connecting the frequency counter.

### ③⑧ Power Connector

The input connector for the ac power cord.

### ③⑨ Fuse Holder

Contains the line fuse. Verify that the proper fuse is installed. (1.2 A)

### ④⑩ Feet/Cord Wrap

Feet support oscilloscope in vertical position (face up) and serve as cord wrap for storing power cord.

# OPERATION

## INITIAL STARTING PROCEDURE

Until you familiarize yourself with the use of all controls, the following procedure may be used to standardize the initial setting of controls as a reference point and to obtain

trace on the CRT in preparation for waveform observation. When using the probe(s), refer to probe's instructions and "PROBE COMPENSATION" listed in APPLICATION of this manual.

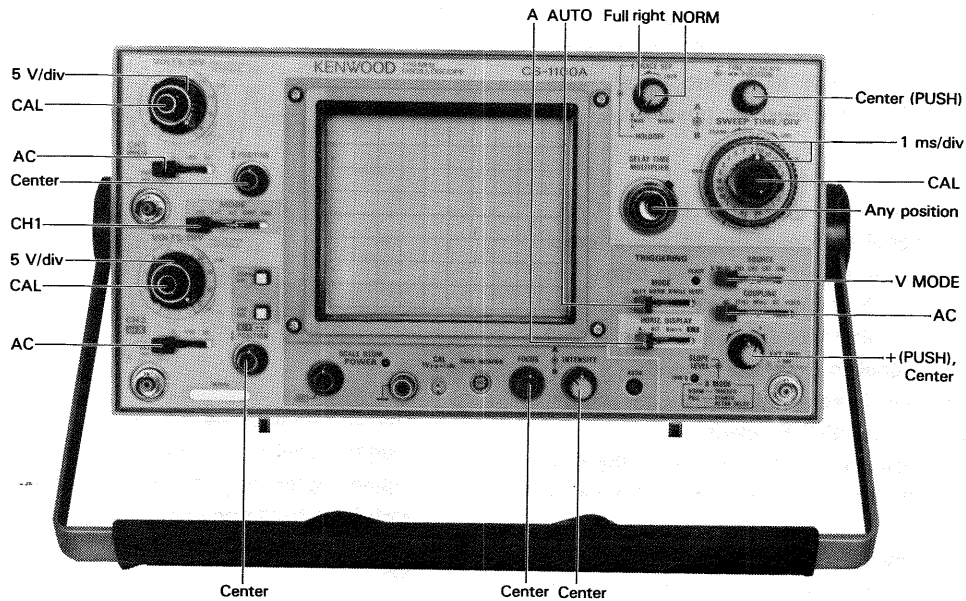

Fig. 5

### (1) NORMAL SWEEP DISPLAY OPERATION

- Turn the POWER switch ⑭ clockwise — the power supply will be turned on and the pilot lamp will light. Set these modes as follows;  
Vertical MODE ⑫ : CH1  
Trigger MODE ⑲ : AUTO  
HORIZ DISPLAY ⑳ : A
- The trace will appear in the center of the CRT display and can be adjusted by the CH1  $\updownarrow$  POSITION ① and  $\leftarrow\rightarrow$  POSITION ③③ controls. Next, adjust the INTENSITY ⑳ and, if necessary, the FOCUS ⑱ for ease of observation.
- Vertical Modes  
With vertical MODE ⑫ set to CH1, apply an input signal to the CH1 INPUT ⑤ jack and adjust the VOLTS/DIV ② control for a suitable size display of the waveform. If the waveform does not appear in the display, adjust the VOLTS/DIV and  $\updownarrow$  POSITION controls to bring the waveform into the center portion of the CRT display. Operation with a signal applied to the CH2 INPUT ⑨ jack and the vertical MODE set to CH2 is similar to the above procedure.  
In the ADD mode, the algebraic sum of CH1 + CH2 is

displayed. If the CH2 INV ⑩ switch has been engaged, the algebraic difference of the two waveforms, CH1 - CH2 is displayed. If both channels are set to the same VOLTS/DIV, the sum or difference can be read directly in VOLTS/DIV from the CRT.

In the ALT or CHOP modes allow simultaneous observation of channel 1 and channel 2 waveforms.

In the CHOP mode, the sweep is chopped at an approximate 250 kHz rate and switched between CH1 and CH2. Note that in the CHOP mode of operation with the SOURCE switch set to V. MODE, the trigger source becomes the chopping signal itself, making waveform observation impossible. Use ALT mode instead in such cases, or select a trigger SOURCE of CH1, or CH2.

If no trace is obtainable, refer to the following TRIGGERING procedures.

- After setting the SOURCE switch, adjust the LEVEL ⑳ SLOPE controls ⑳. The display on the screen will probably be unsynchronized. Refer to TRIGGERING procedure below for adjusting synchronization and sweep speed to obtain a stable display showing the desired number of waveform.

## TRIGGERING

The input signal must be properly triggered for stable waveform observation. TRIGGERING is possible using the input signal INTERNally to create a trigger or with an EXternally provided signal of timing relationship to the observed signal, applying such a signal to the EXT TRIG jack.

The SOURCE switch selects the input signal that is to be used to trigger the sweep, with INT sync possibilities (V.MODE, CH1, CH2, LINE) and EXT sync possibility.

### ★ Internal Sync

When the SOURCE selection is in INT (V.MODE, CH1, CH2, LINE), the input signal is connected to the internal trigger circuit. In this position, a part of the input signal fed to the INPUT ⑤ or ⑨ jack is applied from the vertical amplifier to the trigger circuit to cause the trigger signal triggered with the input signal to drive the sweep.

When the V.MODE position is selected, the trigger source is dependent upon the vertical MODE selection.

When the vertical MODE switch is selected in ALT, the trigger source alternates between channel 1 and channel 2 with each sweep.

When the vertical MODE switch is selected in ALT the trigger source alternates channel 1 and channel 2 with each sweep.

This is convenient for checking amplitudes, waveshape, or waveform period measurements and even permits simultaneous observation of two waveforms which are not related in frequency or period. However, this setting is not suitable for phase or timing comparison measurements. For such measurements, two traces must be triggered by the same sync signal.

When the SOURCE selection is in CH1, the input signal at the channel 1 INPUT ⑤ jack becomes trigger regardless of the position of vertical MODE. When the SOURCE selection is in CH2, the input signal at the channel 2 INPUT ⑨ jack becomes trigger regardless of the position of vertical MODE. If the SOURCE switch is set to the LINE position, triggering is derived from the input line voltage.

This is useful measurements that are related to line frequency.

### ★ External Sync

When the SOURCE selection is in EXT, the input signal at the EXT TRIG ⑰ jack becomes the trigger. This signal must have a time or frequency relationship to the signal being observed to synchronize the display. External sync is preferred for waveform observation in many applications. For example, Fig. 6 shows that the sweep circuit is driven by the gate signal when the gate signal in the burst signal is applied to the EXT TRIG jack. Fig. 6 also shows the input/output signals, where the burst signal generated from the signal is applied to the instrument under test. Thus, accurate triggering can be achieved without regard to the in-

put signal fed to the INPUT ⑤ or ⑨ jack so that no further triggering is required even when the input signal is varied.

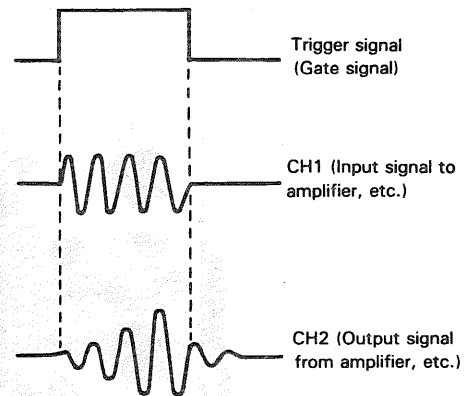

Fig. 6

### ★ Coupling

The COUPLING switch selects the coupling mode of the trigger signal to the trigger circuit according to the type of trigger signal (dc, ac, signal superimposed on dc, signal with high frequency noise.).

#### AC:

Most commonly used position; permits triggering from 20 Hz to over 100 MHz. Blocks dc component of sync trigger signal.

#### LF<sub>REJ</sub>:

Attenuate low-frequency component of sync trigger signal. Useful to reduce low-frequency interference.

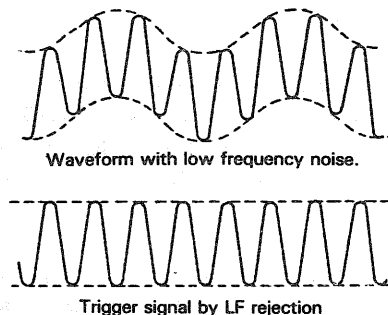

Fig. 7

#### HF<sub>REJ</sub>:

Attenuates high-frequency component of sync trigger signal. Useful to reduce high-frequency noise, and permits triggering from the modulation envelope of an amplitude modulated rf signal.

#### DC:

Permits triggering from dc to over 100 MHz. Couples dc component of sync trigger signal. Useful for triggering from very low frequency signals (below 20 Hz) or ramp waveforms with slow repeating dc.

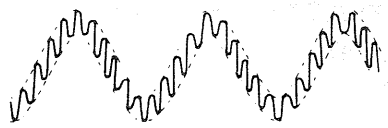

Waveform with high frequency noise



Trigger signal by HF rejection

Fig. 8

★ **Triggering Level**

Trigger point on waveform is adjusted by the LEVEL 22, and SLOPE 23 controls. Fig. 9 shows the relationship between the SLOPE and LEVEL of the trigger point. Triggering level can be adjusted as necessary.

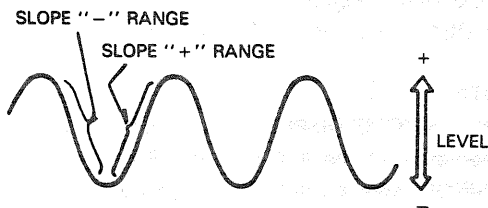

Fig. 9

★ **Auto Trigger**

When the trigger MODE 29 selection is in AUTO, the sweep circuit becomes free-running as long as there is no trigger signal, permitting a check of GND level. When a trigger signal is present, the trigger point can be determined by the LEVEL control for observation as in the normal trigger signal. When the trigger level exceeds the trigger signal, the trigger circuit also becomes free-running where the waveform starts running. When the trigger MODE is set to NORM and/or, when the trigger signal is absent or the triggering level exceeds the signal there is no sweep.

**(2) MAGNIFIED SWEEP OPERATION**

Since merely shortening the sweep time to magnify a portion of an observed waveform can result in the desired portion disappearing off the screen, such magnified display should be performed using the MAGNIFIED SWEEP.

Using the ◀ POSITION control, adjust the desired portion of waveform to the CRT. Pull the ×10 MAG control to magnify the display 10 times. For this type of display the sweep time is the SWEEP TIME/DIV setting divided by 10.

**(3) DELAYED SWEEP OPERATION (ALTERNATING SWEEP OPERATION)**

Delayed sweep operation is achieved by use of both the A sweep and the B sweep.

**Procedure:**

1. First select the HORIZ DISPLAY switch to A and adjust for a normal waveform display.

2. Pull out the SLOPE 23 control to set the B MODE to initiate the STARTS AFTER DELAY mode. Select the HORIZ DISPLAY switch to ALT mode and the B sweep will appear as an intensified portion of the A sweep. The length of the intensified portion is adjusted by the B SWEEP TIME/DIV control.

Adjust TRACE SEP control 35 for easy observation of both the A and B traces. The upper trace is the non-magnified portion of the waveform with the magnified portion super-imposed as an intensified section.

The lower waveform is the intensified portion displayed magnified.

The B sweep intensity is adjusted using the B INTENSITY control 20.

3. Shift the intensified portion of waveform (section to be magnified) along the A sweep by use of the DELAY TIME MULT 34.

4. Select the HORIZ DISPLAY to B DLY'D to display the intensified portion as a magnified B sweep. (Fig. 10)

Delay Time (magnified portion) = DELAY TIME MULT setting × A SWEEP TIME/DIV setting.

5. For STARTS AFTER DELAY operation, apparent jitter increases as magnification increases. To obtain a jitter free display set the B MODE 23 to TRIG. In this "Triggerable After Delay" mode the A trigger signal selected by the SOURCE switch 25 becomes the B trigger source.

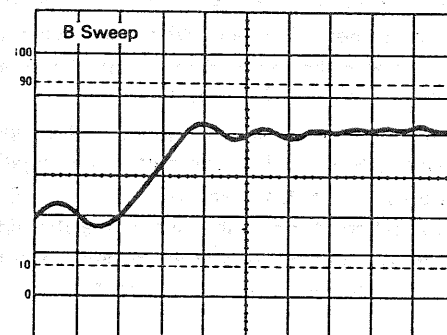
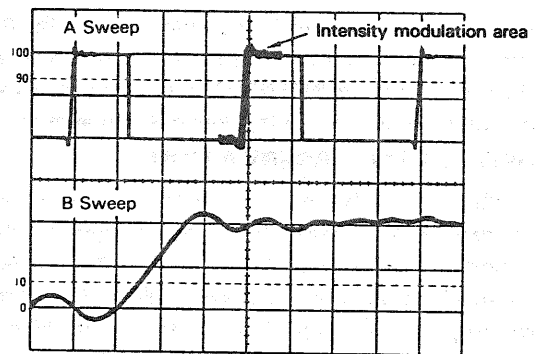

Fig. 10

Note that for this type of operation both the DELAY TIME MULT and trigger LEVEL controls affect the start of the B sweep so that the delay time is used as a reference point.

#### (4) X-Y OPERATION

For some measurements, an external horizontal deflection signal is required. This is also referred to as an X-Y measurement, where the Y input provides vertical deflection and X input provides horizontal deflection.

X-Y operation permits the oscilloscope to perform many types of measurements not possible with conventional sweep operation. The CRT display becomes an electronic graph of two instantaneous voltages. The display may be a direct comparison of two voltages such as during phase measurement, or frequency measurement with Lissajous waveforms.

To use an external horizontal input, use the following procedure;

1. Select the HORIZ DISPLAY switch to X-Y position.
2. Use the channel 1 probe for the vertical input and the channel 2 probe for the horizontal input.
3. Adjust the amount of horizontal deflection with the channel 2 VOLTS/DIV and VARIABLE controls.
4. The channel 2 (vertical) POSITION ⑪ control now serves as the horizontal position control, and the ◀ POSITION control is disabled.
5. All sync controls are disconnected and have no effect. X and Y axis sensitivities are set by using the channel 2 and channel 1 VARIABLE, VOLTS/DIV controls respectively.  
By pulling out the channel 1 and channel 2 VARIABLE controls, the sensitivities of both the Y and X axis are magnified five times. A INTENSITY control is used to adjust the intensity of the display during X-Y operation.

#### (5) VIDEO SIGNAL OBSERVATION

The A SWEEP TIME/DIV control permits selection of vertical or horizontal sync pulse for sweep triggering when viewing composite video waveforms. In the LINE position, (50  $\mu$ s/div to 20 ns/div) horizontal sync pulses are selected as triggers to permit viewing of horizontal line of video. In the FRAME (0.5 s/div to 0.1 ms/div) position, vertical sync pulses are selected as triggers to permit viewing of vertical fields and frames of video. When observing the video waveforms, stable display is obtained on the screen regardless the trigger LEVEL ⑫ control.

At most points of measurement, a composite video signal is of the (-) polarity, that is, the sync pulses are negative and the video is positive. In this case, use " - " SLOPE.

If the waveform is taken at a circuit point where the video waveform is inverted, the sync pulses are positive and the video is negative. In this case, use " + " SLOPE.

#### (6) SINGLE SWEEP OPERATION

This mode of display is useful for looking at non-synchronous or one time events.

Procedure:

1. Select the trigger MODE ⑲ to either AUTO or NORM. Apply a signal of approximately the same amplitude and frequency as the signal that is to be observed as the trigger signal and set the trigger level.
2. Select trigger MODE switch to RESET — observe that the READY indicator LED lights to indicate the reset condition. This LED goes out when the A sweep period is completed.
3. After the above set-up is completed the scope is ready to operate in the SINGLE sweep mode of operation after resetting the instrument using the RESET switch. Input of the trigger signal results in one and only one sweep and READY indicator LED goes out.

#### NOTE:

With the HORIZ DISPLAY set to ALT the simultaneous observation of the A sweep and B sweep waveforms at SINGLE sweep mode is not possible. For dual trace, single sweep operation, vertical MODE must not be set to ALT. Observation is not possible using ALT mode. Set the scope to the CHOP mode in this case.



# APPLICATIONS

## PROBE COMPENSATION

If accurate measurements are to be made, the effect of the probe being used must be properly adjusted output of the measurement system using the internal calibration signal or some other square wave source.

1. Connect probe to INPUT jack. Connect ground clip of probe of oscilloscope ground terminal and touch tip of probe to CAL terminal.
2. Connect the probe to the CAL terminal on the front panel, and adjust the SWEEP TIME/DIV switch so that several cycles of this signal are displayed.
3. Adjust compensation trimmer on probe for optimum square wave waveshape (minimum overshoot, rounding off, and tilt).

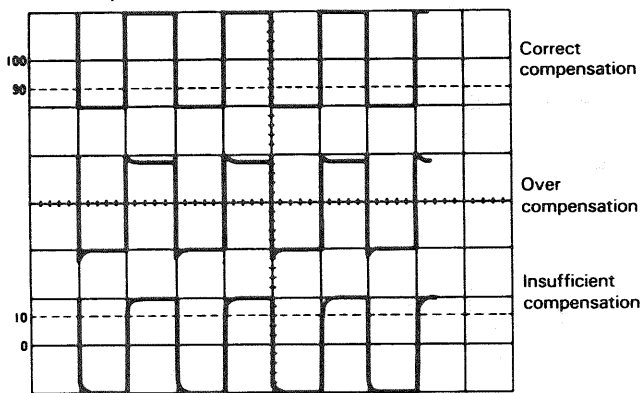

Fig. 11

## TRACE ROTATION COMPENSATION

Rotation from a horizontal trace position can be the cause of measurement errors.

Adjust the controls for a single display. Set the AC-GND-DC switch to GND and trigger MODE to AUTO. Adjust the POSITION control such that the trace is over the center horizontal graticule line. If the trace appears to be rotated from horizontal, align it with the center graticule line using the TRACE ROTATION control located on the front panel.

## DC VOLTAGE MEASUREMENTS

This procedure describes the measurement procedure for waveforms including the dc component.

Procedure:

1. Connect the signal to be measured to the INPUT jack. Set the vertical MODE to the channel to be used. Set the VOLTS/DIV and SWEEP TIME/DIV switch to obtain a normal display of the waveform to be measured. Set the VARIABLE control to CAL position.
2. Set the trigger MODE switch to AUTO and AC-GND-DC to the GND position, which established the zero volt reference. Using the POSITION control, adjust the trace position to the desired reference level position, making sure not to disturb this setting once made.

3. Set the AC-GND-DC switch to the DC position to observe the input waveform, including its dc component. If an appropriate reference level or VOLTS/DIV setting was not made, the waveform may not be visible on the CRT screen at this point. If so, reset VOLTS/DIV and/or the POSITION control.
4. Use the POSITION control to bring the portion of the waveform to be measured to the center vertical graduation line of the CRT screen.
5. Measure the vertical distance from the reference level to the point to be measured, (the reference level can be rechecked by setting the AC-GND-DC switch again to GND).

Multiply the distance measured above by the VOLTS/DIV setting and the probe attenuation ratio as well. If "x 5 GAIN" has been set, multiply the value by 1/5 as well. Voltages above and below the reference level are positive and negative values respectively.

Using the formula:

DC level = Vertical distance in divisions  $\times$  (VOLTS/DIV setting)  $\times$  (probe attenuation ratio)  $\times$  "x 5 GAIN" value  $^{-1(1/5)}$

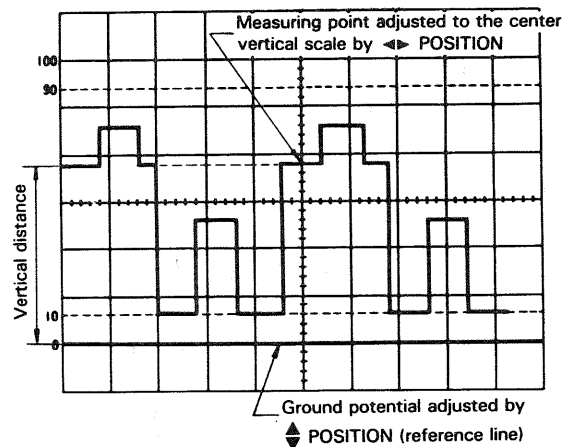

Fig. 12

### [EXAMPLE]

For the example, the point being measured is 3.8 divisions from the reference level (ground potential).

If the VOLTS/DIV was set to 0.2 V and a 10:1 probe was used. (See Fig. 12)

Substituting the given values:

$$\text{DC level} = 3.8 \text{ (div)} \times 0.2 \text{ (V)} \times 10 = 7.6 \text{ V}$$

## MEASUREMENT OF THE VOLTAGE BETWEEN TWO POINTS ON A WAVEFORM

This technique can be used to measure peak-to-peak voltages.

### Procedure:

1. Apply the signal to be measured to the INPUT jack. Set the vertical MODE to the channel to be used. Set the AC-GND-DC switch to AC, adjusting VOLTS/DIV and SWEEP TIME/DIV controls for a normal display. Set the VARIABLE control to CAL position.
2. Using the  $\blacktriangle$  POSITION control, adjust the waveform position such that one of the two points falls on a CRT graduation line and that the other is visible on the display screen.
3. Using the  $\blacktriangleleft$  POSITION control, adjust the second point to coincide with the center vertical graduation line.
4. Measure the vertical distance between the two points and multiply this by the setting of the VOLTS/DIV control. If "x 5 GAIN" has been set, multiply the value by 1/5 as well.

If a probe is used, further multiply this by the attenuation ratio.

### Using the formula:

$$\begin{aligned} \text{Volts Peak-to-Peak} \\ = \text{Vertical distance (div)} \times (\text{VOLTS/DIV setting}) \times (\text{probe} \\ \text{attenuation ratio}) \times \text{"x 5 GAIN"} \text{ value}^{-1}(1/5) \end{aligned}$$

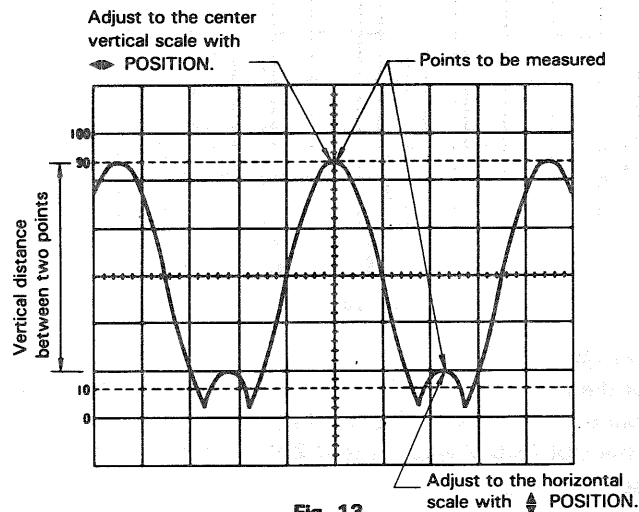

Fig. 13

### [EXAMPLE]

For the example, the two points are separated by 4.4 divisions vertically. Set the VOLTS/DIV setting be 0.2 V/div and the probe attenuation be 10:1. (See Fig. 13)

### Substituting the given value:

$$\text{Voltage between two points} = 4.4 \text{ (div)} \times 0.2 \text{ (V)} \times 10 = 8.8 \text{ V}$$

## ELIMINATION OF UNDESIRABLE SIGNAL COMPONENTS

The ADD feature can be conveniently used to cancel out the effect of an undesired signal component which may be superimposed on the signal you wish to observe. (See Fig. 14)

### Procedure:

1. Apply the signal containing an undesired component to the channel 1 INPUT jack and the undesired signal itself alone to the channel 2 INPUT jack.
2. Set the vertical MODE switch to CHOP and SOURCE to CH2. Verify that CH2 represents the unwanted signal in reverse polarity. If necessary reverse polarity by setting CH2 INV push button.
3. Set the vertical MODE to ADD, SOURCE to V. MODE and channel 2 VOLTS/DIV and VARIABLE controls so that the undesired signal component is cancelled as much as possible. The remaining signal should be the signal you wish to observe alone and free of the unwanted signal.

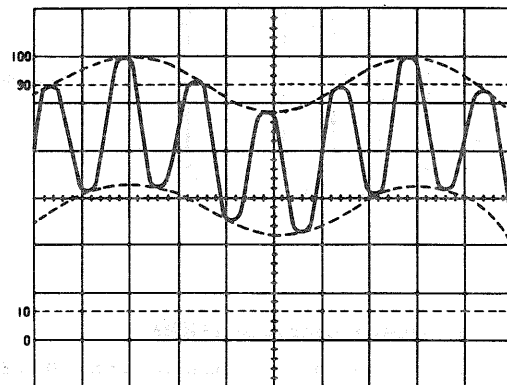

Signal containing undesired component  
(Broken lines: undesired component envelope)

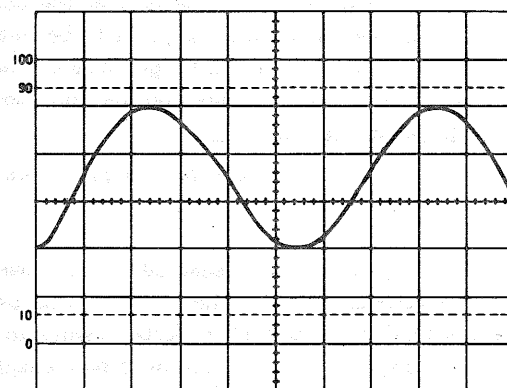

Undesired component signal

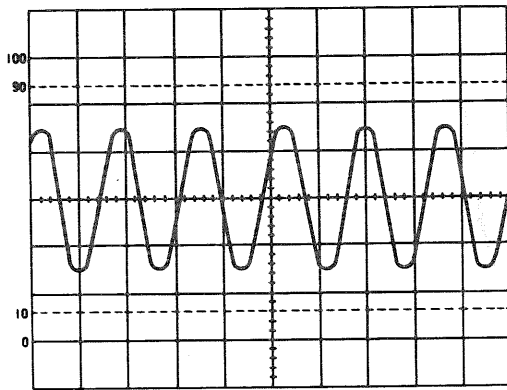

Signal without undesired component

Fig. 14

### TIME MEASUREMENTS

This is the procedure for making time measurements between two points on a waveform. The combination of the SWEEP TIME/DIV and the horizontal distance in divisions between the two points is used in the calculation.

#### Procedure:

1. Apply the signal to be measured to the INPUT jack. Set the vertical MODE to the channel to be used. Adjust the VOLTS/DIV and SWEEP TIME/DIV for a normal display. Be sure that the VARIABLE control is set to CAL position.
2. Using the  $\blacktriangle$  POSITION control, set one of the points to be used as a reference to coincide with the horizontal centerline. Use the  $\blacktriangleleft \blacktriangleright$  POSITION control to set this point at the intersection of any vertical graduation line.
3. Measure the horizontal distance between the two points. Multiply this by the setting of the SWEEP TIME/DIV control to obtain the time between the two points. If horizontal "x 10 MAG" is used, multiply this further by 1/10.

#### Using the formula:

Time = Horizontal distance (div)  $\times$  (SWEEP TIME/DIV setting)  $\times$  "x 10 MAG" value<sup>-1</sup> (1/10)

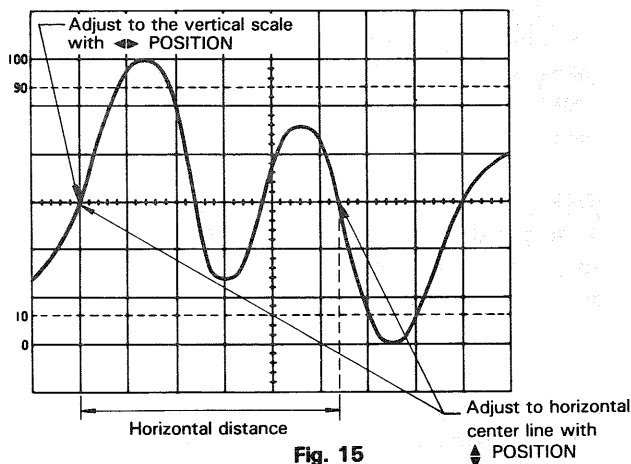

Fig. 15

### [EXAMPLE]

For the example, the horizontal distance between the two points is 5.4 divisions.

If the SWEEP TIME/DIV is 0.2 ms/div we calculate. (See Fig. 15)

Substituting the given value:

$$\text{Time} = 5.4 \text{ (div)} \times 0.2 \text{ (ms)} = 1.08 \text{ ms}$$

### FREQUENCY MEASUREMENTS

Frequency measurements are made by measuring the period of one cycle of waveform and taking the reciprocal of this time value as the frequency.

#### Procedure:

1. Set the oscilloscope up to display one cycle of waveform (one period).
2. The frequency is the reciprocal of the period measured.

#### Using the formula:

$$\text{Freq} = \frac{1}{\text{period}}$$

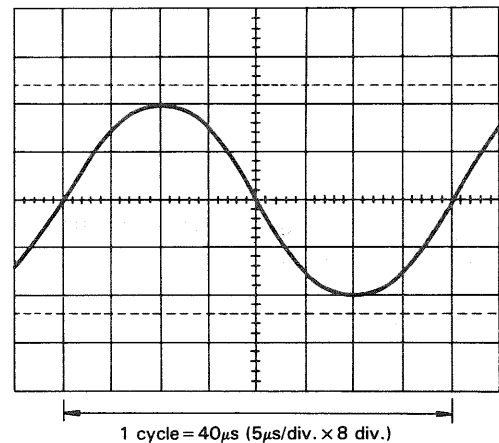

Fig. 16

### [EXAMPLE]

A period of 40  $\mu$ s is observed and measured. (See Fig. 16)

Substituting the given value:

$$\text{Freq} = 1/[40 \times 10^{-6}] = 2.5 \times 10^4 = 25 \text{ kHz}$$

While the above method relies on the measurement directly of the period of one cycle, the frequency may also be measured by counting the number of cycles present in a given time period.

1. Apply the signal to the INPUT jack. Select the vertical MODE to the channel to be used and adjusting the various controls for a normal display. Set the VARIABLE control to CAL position.
2. Count the number of cycles of waveform between a chosen set of vertical graduation lines.

Using the horizontal distance between the vertical lines used above and the SWEEP TIME/DIV, the time span may be calculated. Multiply the reciprocal of this value by the number of cycles present in the given time span. If "× 10 MAG" is used multiply this further by 10. Note that errors will occur for displays having only a few cycles.

Using the formula:

$$\text{Freq} = \frac{\# \text{ of cycles} \times \text{"} \times 10 \text{ MAG" value}}{\text{Horizontal distance (div)} \times \text{SWEEP TIME/DIV setting}}$$

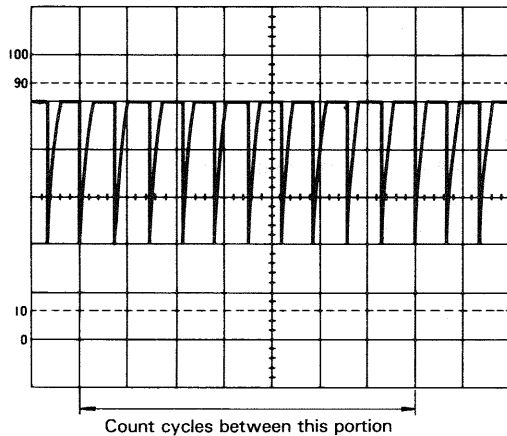

Fig. 17

**[EXAMPLE]**

For the example, within 7 divisions there are 10 cycles. The SWEEP TIME/DIV is 5 μs. (See Fig. 17)

Substituting the given value:

$$\text{Freq} = \frac{10}{7 \text{ (div)} \times 5 \text{ (}\mu\text{s)}} \cong 285.7 \text{ kHz}$$

**PULSE WIDTH MEASUREMENTS**

Procedure:

1. Apply the pulse signal to the INPUT jack. Set the vertical MODE to the channel to be used.
2. Use the VOLTS/DIV, VARIABLE and  $\blacktriangledown$  POSITION controls to adjust the waveform such that the pulse is easily observed and such that the center pulse width coincides with the center horizontal line on the CRT screen.
3. Measure the distance between the intersection of the pulse waveform and the center horizontal line in divisions. Be sure that the VARIABLE control is in the CAL. Multiply this distance by the SWEEP TIME/DIV and by 1/10 if "× 10 MAG" mode is being used.

Using the formula:

$$\text{Pulse width} = \text{Horizontal distance (div)} \times (\text{SWEEP TIME/DIV setting}) \times \text{"} \times \text{MAG } 10\text{" value}^{-1} (1/10)$$

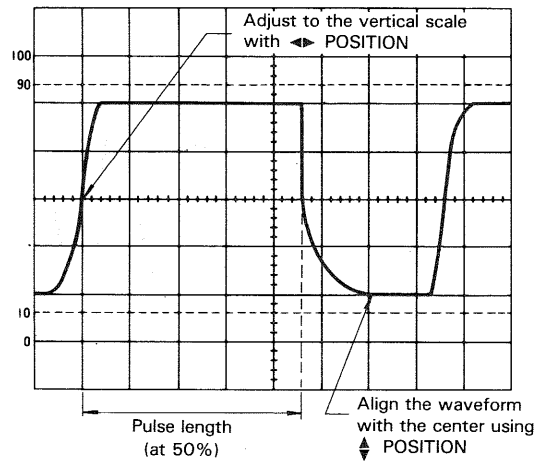

Fig. 18

**[EXAMPLE]**

For the example, the distance (width) at the center horizontal line is 4.6 divisions and the SWEEP TIME/DIV is 0.2 ms. (See Fig. 18)

Substituting the given value:

$$\text{Pulse width} = 4.6 \text{ (div)} \times 0.2 \text{ ms} = 0.92 \text{ ms}$$

**PULSE RISETIME AND FALLTIME MEASUREMENTS**

For risetime and falltime measurements, the 10% and 90% amplitude points are used as starting and ending reference points.

Procedure:

1. Apply a signal to the INPUT jack. Set the vertical MODE to the channel to be used. Use the VOLTS/DIV and VARIABLE controls to adjust the waveform peak-to-peak height to six divisions.
2. Using the  $\blacktriangledown$  POSITION control and the other controls, adjust the display such that the waveform is centered vertically in the display. Set the SWEEP TIME/DIV to as fast a setting as possible consistent with observation of both the 10% and 90% points. Set the VARIABLE control to CAL position.
3. Use the  $\blacktriangleleft$  POSITION control to adjust the 10% point to coincide with a vertical graduation line and measure the distance in divisions between the 10% and 90% points on the waveform. Multiply this by the SWEEP TIME/DIV and also by 1/10, if "× 10 MAG" mode was used.

**NOTE:**

Be sure that the correct 10% and 90% lines are used. For such measurements the 0, 10, 90 and 100% points are marked on the CRT screen.

Using the formula:

$$\text{Risetime} = \text{Horizontal distance (div)} \times (\text{SWEEP TIME/DIV setting}) \times \text{"} \times 10 \text{ MAG" value}^{-1} (1/10)$$

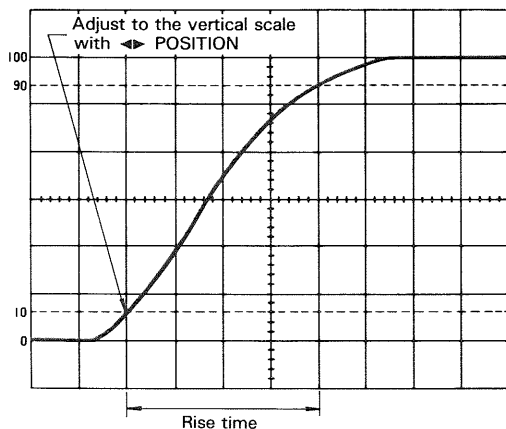

Fig. 19

**[EXAMPLE]**

For the example, the horizontal distance is 4.0 divisions. The SWEEP TIME/DIV is 2  $\mu$ s. (See Fig. 19)

Substituting the given value:  
 Risetime = 4.0 (div)  $\times$  2 ( $\mu$ s) = 8 $\mu$ s

Risetime and falltime can be measured by making use of the alternate step 3 as described below as well.

- Use the  $\blacktriangleleft$  POSITION control to set the 10% point to coincide with the center vertical graduation line and measure the horizontal distance to the point of the intersection of the waveform with the center horizontal line. Let this distance be  $D_1$ . Next adjust the waveform position such that the 90% point coincides with the vertical centerline and measure the distance from that line to the intersection of the waveform with the horizontal centerline. This distance is  $D_2$  and the total horizontal distance is then  $D_1$  plus  $D_2$  for use in the above relationship in calculating the risetime or falltime.

Using the formula:

$$\text{Risetime} = (D_1 + D_2) (\text{div}) \times (\text{SWEEP TIME/DIV setting}) \times \text{"} \times 10 \text{ MAG" value}^{-1} (1/10)$$

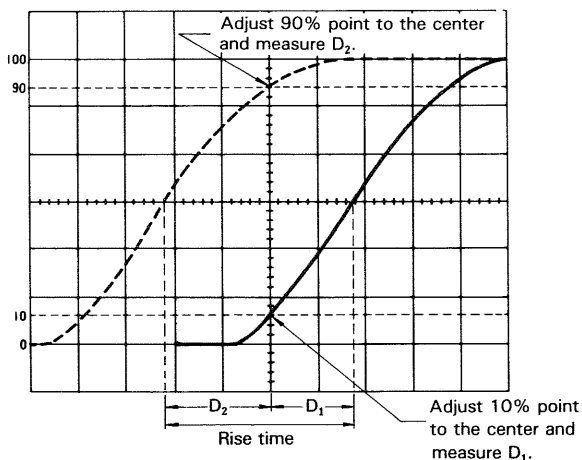

Fig. 20

**[EXAMPLE]**

For the example, the measured  $D_1$  is 1.8 divisions while  $D_2$  is 2.2 divisions. If SWEEP TIME/DIV is 2  $\mu$ s we use the following relationship. (See Fig. 20)

Substituting the given value:  
 Risetime = (1.8 + 2.2) (div)  $\times$  2 ( $\mu$ s) = 8  $\mu$ s

**TIME DIFFERENCE MEASUREMENTS**

This procedure is useful in measurement of time differences between two signals that are synchronized to one another but skewed in time.

Procedure:

- Apply the two signals to channel 1 and channel 2 INPUT jacks. Set the vertical MODE switch to either ALT or CHOP mode. Generally for low frequency signals CHOP is chosen with ALT used for high frequency signals.
- Select the faster of the two signals as the SOURCE and use the VOLTS/DIV and SWEEP TIME/DIV to obtain an easily observed display. Set the VARIABLE control to CAL position.
- Using the  $\blacktriangle$  POSITION control set the waveforms to the center of the CRT display and use the  $\blacktriangleleft$  POSITION control to set the reference signal to be coincident with a vertical graduation line.
- Measure the horizontal distance between the two signals and multiply this distance in divisions by the SWEEP TIME/DIV setting. If " $\times 10$  MAG" is being used multiply this again by 1/10.

Using the formula:

$$\text{Time} = \text{Horizontal distance (div)} \times (\text{SWEEP TIME/DIV setting}) \times \text{"} \times 10 \text{ MAG" value}^{-1} (1/10)$$

**[EXAMPLE]**

For the example, the horizontal distance measured is 4.4 divisions. The SWEEP TIME/DIV is 0.2 ms. (See Fig. 21)

Substituting the given value:

$$\text{Time} = 4.4 (\text{div}) \times 0.2 (\text{ms}) = 0.88 \text{ ms}$$

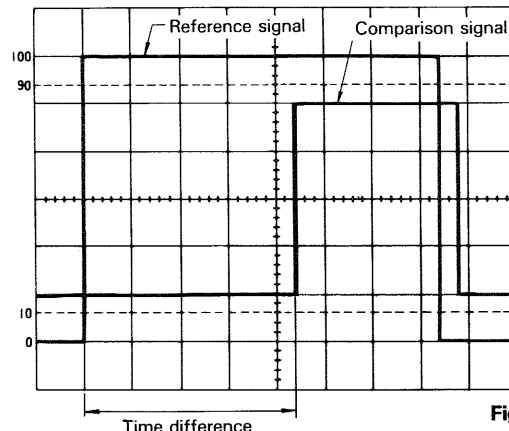

Fig. 21 21

## PHASE DIFFERENCE MEASUREMENTS

This procedure is useful in measuring the phase difference of signals of the same frequency.

Procedure:

1. Apply the two signals to the channel 1 and channel 2 INPUT jacks, setting the vertical MODE switch to either CHOP or ALT mode.
2. Set the SOURCE to the signal which is leading in phase and use the VOLTS/DIV to adjust the signals such that they are equal in amplitude. Adjust the other controls for a normal display.
3. Use the SWEEP TIME/DIV and A VARIABLE controls to adjust the display such that one cycle of the signals occupies 8 divisions of horizontal display. Use the POSITION control to bring the signals in the center of the screen. Having set up the display as above, one division now represents  $45^\circ$  in phase.
4. Measure the horizontal distance between corresponding points on the two waveforms.

Using the formula:

$$\text{Phase difference} = \text{Horizontal distance (div)} \times 45^\circ/\text{div}$$

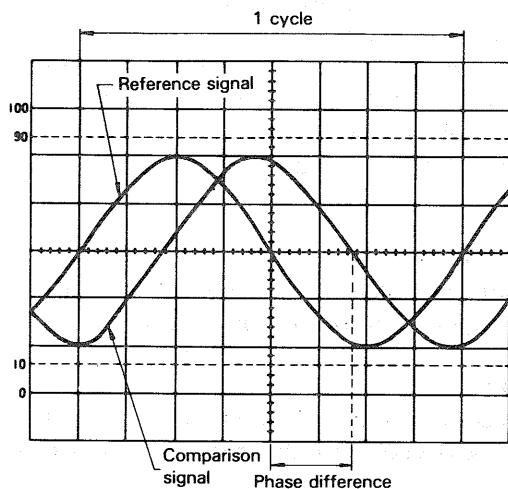

Fig. 22

### [EXAMPLE]

For the example, the horizontal distance is 1.7 divisions. (See Fig. 22)

Substituting the given value:

$$\text{The phase difference} = 1.7 (\text{div}) \times 45^\circ/\text{div} = 76.5^\circ$$

The above setup allows  $45^\circ$  per division but if more accuracy is required the SWEEP TIME/DIV may be changed and magnified without touching the VARIABLE control and if necessary the trigger level can be readjusted.

In this case, the phase difference can be obtained from the SWEEP TIME/DIV setting for 8 divisions/cycle and the new SWEEP TIME/DIV setting changed for higher accuracy, by using the following formula.

$$\text{Phase difference} = \text{Horizontal distance of new sweep range (div)} \times 45^\circ/\text{div} \times \frac{\text{New SWEEP TIME/DIV setting}}{\text{Original SWEEP TIME/DIV setting}}$$

Another simple method of obtaining more accuracy quickly is to simply use  $\times 10$  MAG for a scale of  $4.5^\circ/\text{div}$ .

## RELATIVE MEASUREMENT

If the frequency and amplitude of some reference signal are known, an unknown signal may be measured for level and frequency without use of the VOLTS/DIV or SWEEP TIME/DIV for calibration.

The measurement is made in units relative to the reference signal.

### ★ Vertical Sensitivity

Setting the relative vertical sensitivity using a reference signal.

Procedure:

1. Apply the reference signal to the INPUT jack and adjust the display for a normal waveform display. Adjust the VOLTS/DIV and VARIABLE controls so that the signal coincides with the CRT face's graduation lines. After adjusting, be sure not to disturb the setting of the VARIABLE control.

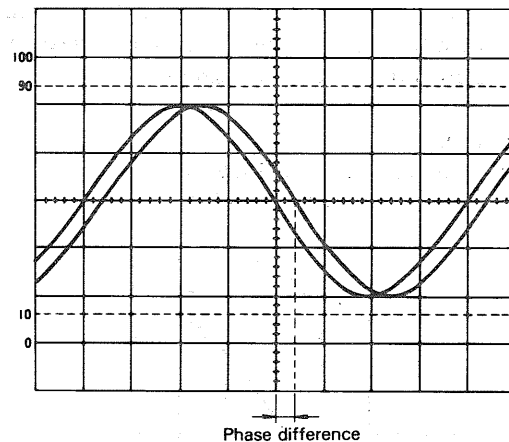

One cycle adjusted to occupy 8 div.

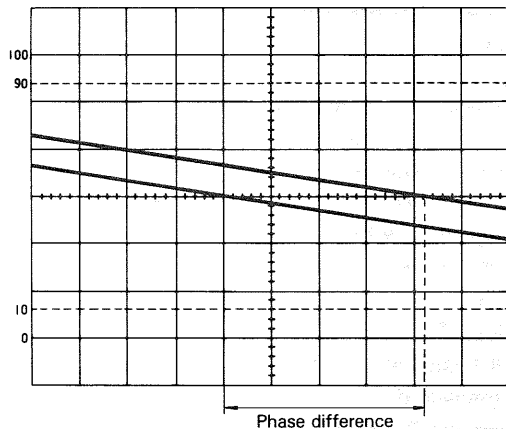

Expanded sweep waveform display.

Fig. 23

- The vertical calibration coefficient is now the reference signal's amplitude (in volts) divided by the product of the vertical amplitude set in step 1 and the VOLTS/DIV setting.

Using the formula:  
Vertical coefficient

$$= \frac{\text{Voltage of the reference signal (V)}}{\text{Vertical amplitude (div)} \times \text{VOLTS/DIV setting}}$$

- Remove the reference signal and apply the unknown signal to the INPUT jack, using the VOLTS/DIV control to adjust the display for easy observation. Measure the amplitude of the displayed waveform and use the following relationship to calculate the actual amplitude of the unknown waveform.

Using the formula:

Amplitude of the unknown signal (V)

$$= \text{Vertical distance (div)} \times \text{Vertical coefficient} \times \text{VOLTS/DIV setting}$$

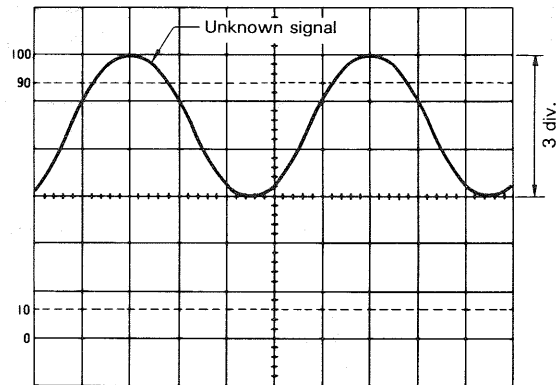
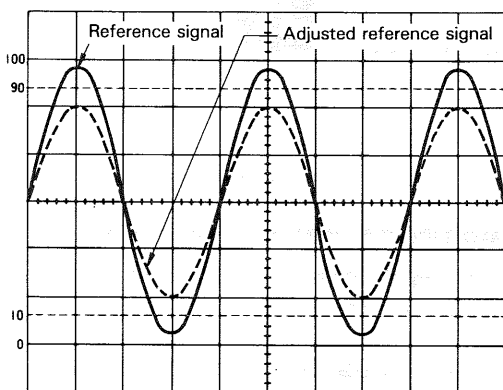

Fig. 24

**[EXAMPE]**

For the example, the VOLTS/DIV is 1 V.

The reference signal is 2 Vrms. Using the VARIABLE, adjust so that the amplitude of the reference signal is 4 divisions. (See Fig. 24)

Substituting the given value:

$$\text{Vertical coefficient} = \frac{2 \text{ Vrms}}{4 \text{ (div)} \times 1 \text{ (V)}} = 0.5$$

Then measure the unknown signal and VOLTS/DIV is 2 V and vertical amplitude is 3 divisions.

Substituting the given value:

$$\begin{aligned} \text{Effective value of unknown signal} &= 3 \text{ (div)} \times 0.5 \times 5 \text{ (V)} \\ &= 7.5 \text{ V rms} \end{aligned}$$

★ **Period**

Setting the relative sweep coefficient with respect to a reference frequency signal.

Procedure:

- Apply the reference signal to the INPUT jack, using the VOLTS/DIV and VARIABLE to obtain an easily observed waveform display. Using the SWEEP TIME/DIV and A VARIABLE controls adjust one cycle of the reference signal to occupy a fixed number of scale divisions accurately. After this is done, be sure not to disturb the setting of the VARIABLE control.
- The Sweep (horizontal) calibration coefficient is then the period of the reference signal divided by the product of the number of divisions used in step 1 for setup of the reference and the setting of the SWEEP TIME/DIV control.

Using the formula:

Sweep coefficient

$$= \frac{\text{Period of the reference signal (sec)}}{\text{Horizontal width (div)} \times \text{SWEEP TIME/DIV setting}}$$

- Remove the reference signal and input the unknown signal, adjusting the SWEEP TIME/DIV control for easy observation.

Measure the width of one cycle in divisions and use the following relationship to calculate the actual period.

Using the formula:

Period of unknown signal = Width of 1 cycle (div) × sweep coefficient × SWEEP TIME/DIV setting

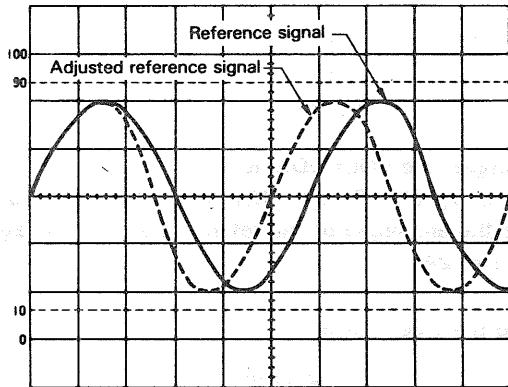

Fig. 25

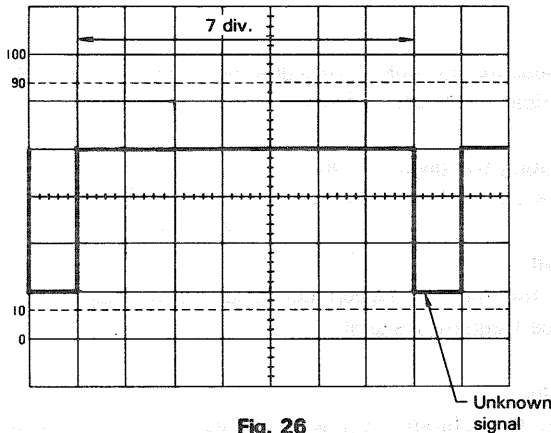

Fig. 26

**[EXAMPLE]**

SWEEP TIME/DIV is 0.1 ms and apply 1.75 kHz reference signal. Adjust the A VARIABLE so that the distance of one cycle is 5 divisions.

Substituting the given value:

$$\text{Horizontal coefficient} = \frac{1.75 \text{ (kHz)}^{-1}}{5 \times 0.1 \text{ (ms)}} = 1.142$$

Then, SWEEP TIME/DIV is 0.2 ms and horizontal amplitude is 7 divisions. (See Fig. 26)

Substituting the given value:

$$\text{Pulse width} = 7 \text{ (div)} \times 1.142 \times 0.2 \text{ (ms)} \approx 1.6 \text{ ms}$$

**PULSE JITTER MEASUREMENT**

- Apply the signal to the INPUT jack and set the vertical MODE to the channel to be used.  
Use the VOLTS/DIV to adjust for an easy to observe waveform display. Special care should be taken to adjust the trigger group of controls for a stable display. Set the A VARIABLE to CAL position.
- Select the HORIZ DISPLAY to ALT and pull out the SLOPE switch to affect the STARTS AFTER DELAY mode.  
Adjust TRACE SEP control and the DELAY TIME MULT control for intensified display of the waveform to be measured.
- Using the B SWEEP TIME/DIV adjust the display for intensification of the entire jitter area of the waveform.
- Select the HORIZ DISPLAY to B DLY'D.  
Measure the width of the jitter area.  
The jitter time is this width in division multiplied by the setting of the B SWEEP TIME/DIV control.

Using the formula:

$$\text{Pulse jitter} = \text{Jitter width (div)} \times \text{B SWEEP TIME/DIV setting}$$

**[EXAMPLE]**

The example shows a case in which the jitter width was measured at 1.6 divisions wide with the B SWEEP TIME/DIV set at 0.2 μs. (See Fig. 27)

Substituting the given value:

$$\text{Pulse jitter} = 1.6 \text{ (div)} \times 0.2 \text{ (}\mu\text{s)} = 0.32 \mu\text{s}$$

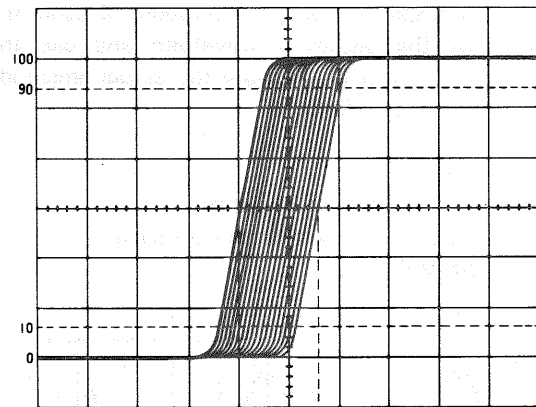

Fig. 27

**SWEEP MULTIPLICATION (MAGNIFICATION)**

The apparent magnification of the delayed sweep is determined by the values set by the A and B SWEEP TIME/DIV controls.

- Apply a signal to the INPUT jack and set the vertical MODE to the channel to be used, adjusting VOLTS/DIV for an easily observed display of the waveform and the other controls if necessary.



- Set the A SWEEP TIME/DIV so that several cycles of the waveform are displayed. Pull out the SLOPE switch to affect the STARTS AFTER DELAY mode.

When the HORIZ DISPLAY is set to ALT, the magnified portion of the waveform will appear intensified on the CRT display. Adjust the POSITION and TRACE SEP controls to shift the waveform to desired position.

- Use the DELAY TIME MULT to shift the intensified portion of waveform to correspond with the section to be magnified for observation. Use the B SWEEP TIME/DIV to adjust intensified portion to cover the entire portion to be magnified.
- Time measurements are performed in the same manner from the B sweep as was described above for A sweep time measurements.

The apparent magnification of the intensified waveform section is the A SWEEP TIME/DIV divided by the B SWEEP TIME/DIV.

Using the formula:

$$\text{The apparent magnification of the intensified waveform} = \frac{\text{A SWEEP TIME/DIV setting}}{\text{B SWEEP TIME/DIV setting}}$$

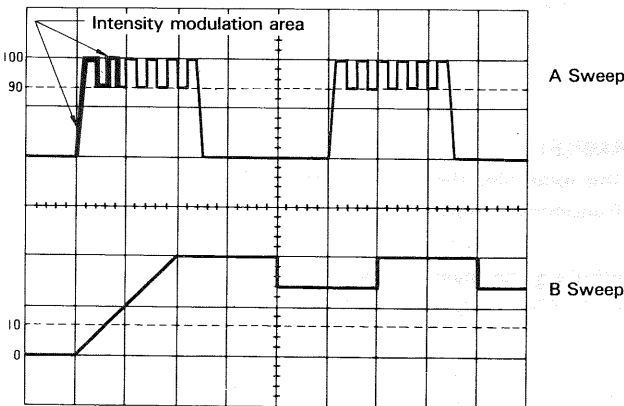

Fig. 28

**[EXAMPLE]**

In the example, the A SWEEP TIME is  $2 \mu\text{s}$  and the B SWEEP TIME is  $0.2 \mu\text{s}$ . (See Fig. 28)

Substituting the given value:

$$\text{Apparent magnification ratio} = \frac{2 \times 10^{-6}}{0.2 \times 10^{-6}} = 10$$

With the above magnification, if the magnification ratio is increased, delay jitter will occur.

To achieve a stable display, set the B MODE to TRIGGER and used the triggered mode of operation.

- Perform the above steps 1 through 3.
- Push the SLOPE switch to cancel the STARTS AFTER DELAY mode and set the B MODE to TRIGGER.
- Select the HORIZ DISPLAY to either ALT or B DLY'D. The apparent magnification will be the same as described above.

**DELAYED SWEEP TIME MEASUREMENT**

Using the B sweep, high accuracy time measurements can be made.

- Apply a signal to INPUT jack and set the vertical MODE to the channel to be used. Adjust the VOLTS/DIV and the other controls if necessary to obtain an easily observed waveform display. Set the A VARIABLE control to CAL position.
- Adjust the A SWEEP TIME/DIV to display the portion of waveform to be measured. Pull out the SLOPE switch to affect the STARTS AFTER DELAY mode. Select the HORIZ DISPLAY to ALT and adjust the B SWEEP TIME/DIV for as small as possible an intensified region.
- Using the POSITION control adjust the waveform position so as to intersect with the center horizontal line on the CRT screen. Use the DELAY TIME MULT so that the intensified portion of waveform touches the center horizontal line and record the setting of the DELAY TIME MULT at this point.
- Use the DELAY TIME MULT to adjust intensified portion to same point of the second waveform. The waveform period is the second dial reading minus the first dial reading multiplied by the A SWEEP TIME/DIV setting.

Using the formula:

$$\text{Period} = (\text{2nd dial reading} - \text{1st dial reading}) \times \text{Delayed sweep time (A SWEEP TIME/DIV setting)}$$

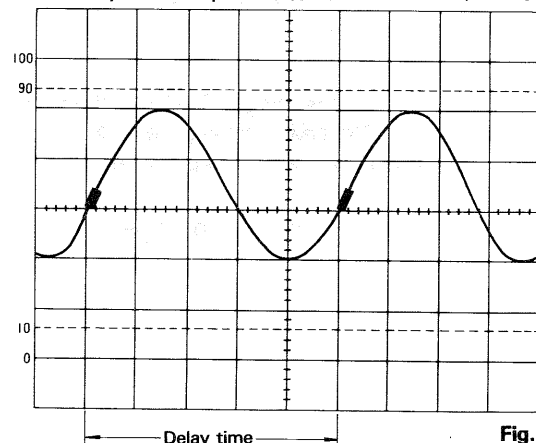

Fig. 29

**[EXAMPLE]**

For the example the first dial setting is 1.01 and the second is 6.04. The setting of A SWEEP TIME/DIV is 2 ms. (See Fig. 29)

Substituting the given value:

$$\text{Period} = (6.04 - 1.01) \times 2 \text{ (ms)} = 10.06 \text{ ms}$$

**PULSE WIDTH MEASUREMENTS USING DELAYED SWEEP**

This method is similar to the time measurement method and can be used for high accuracy pulse width measurements.

1. Apply the pulse signal to the INPUT jack and set the vertical MODE to the channel to be used.
2. Use the VOLTS/DIV, VARIABLE and POSITION controls to adjust the display such that the waveform is easily observable with the center of the pulse width coinciding with the center horizontal graduation line. Set the A VARIABLE to CAL position.

3. Set the A SWEEP TIME/DIV to display the portion of the waveform to be measured. Pull out the SLOPE switch to affect the STARTS AFTER DELAY mode. Adjust the POSITION and TRACE SEP controls to shift the waveform to desired position.

Select the HORIZ DISPLAY to ALT, and adjust the B SWEEP TIME/DIV for as short as possible an intensified section of waveform.

4. Using the DELAY TIME MULT, adjust the display so that the intensified portion touches the center horizontal graduation line of the CRT screen and record the dial setting at this point.
5. Using the DELAY TIME MULT adjust the falling edge of the pulse so that it touches the center horizontal graduation line and is intensified.

The pulse width is the second dial reading minus the first dial reading multiplied by the A SWEEP TIME/DIV setting.

Using the formula:

$$\text{Pulse width} = (\text{2nd dial reading} - \text{1st dial reading}) \times \text{Delayed sweep time (A SWEEP TIME/DIV setting)}$$

**[EXAMPLE]**

In the example, the first dial reading is 0.61 and the second is 5.78 with the A SWEEP TIME/DIV setting at 2 μs. Substituting the appropriate values. (See Fig. 30)

$$\text{Pulse width} = (5.78 - 0.61) \times 2 \text{ (}\mu\text{s)} = 10.34 \text{ }\mu\text{s}$$

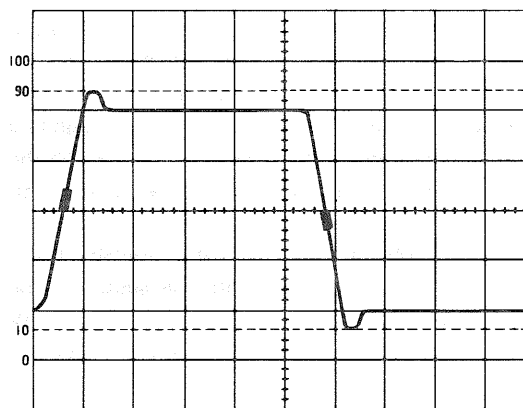

Fig. 30

**FREQUENCY MEASUREMENTS USING DELAYED SWEEP**

The frequency is obtained as the reciprocal of the period of one cycle.

1. Measure the period of the waveform using the procedure described above for time measurement.
2. The frequency is then the reciprocal of the period measured.

Using the formula:

$$\text{Freq} = \frac{1}{\text{Period}}$$

**[EXAMPLE]**

For the example, the period measured is 40.2 μs, making the frequency simply. (See Fig. 31)

Substituting the given value:

$$\text{Freq} = 1 / (40.2 \times 10^{-6}) \approx 24.88 \text{ kHz}$$

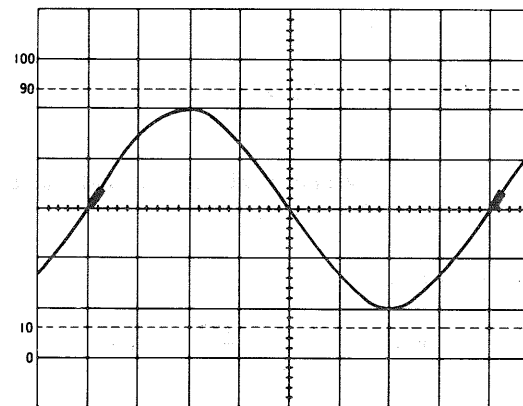

Fig. 31

## PULSE REPETITION TIME

Using the delayed sweep feature, reliable time measurements can be made.

1. Apply a signal to the INPUT jack and set the vertical MODE to the channel to be used.  
Adjust the VOLTS/DIV to obtain a normal easy to view display of the waveform are displayed.
2. Adjust the A SWEEP TIME/DIV so that at least two cycles of the waveform are displayed.  
Select the HORIZ DISPLAY to A and set the B MODE to affect the STARTS AFTER DELAY mode of operation.  
Set the B SWEEP TIME/DIV as fast a sweep speed as possible.
3. Adjust the TRACE SEP control to shift B sweep to desired position. Using the DELAY TIME MULT, adjust the intensified portion to coincide with the first pulse.
4. Using the DELAY TIME MULT, set the pulse to coincide with one of the vertical graduation lines and record the dial setting at this point.
5. Using the DELAY TIME MULT, adjust the second pulse in the same manner to the vertical line used in step 4, recording this dial setting as well. The pulse repetition time is the second dial reading minus the first dial reading multiplied by the A SWEEP TIME/DIV control setting.

Using the formula:

Pulse repetition time = (2nd dial reading - 1st dial reading) × Delayed sweep time (A SWEEP TIME/DIV setting)

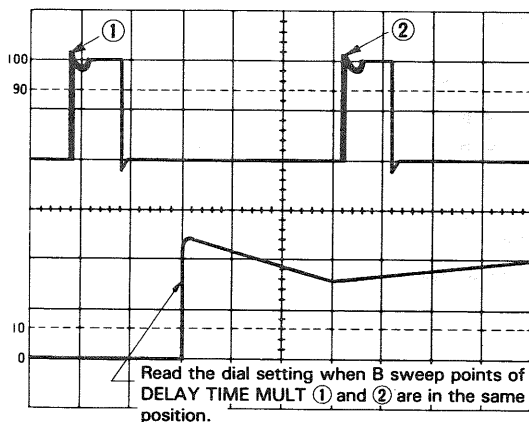

Fig. 32

### [EXAMPLE]

For the example, the first dial reading is 0.76 and the second is 6.22 with the A SWEEP TIME/DIV set at 2  $\mu$ s. We have, substituting the appropriate values. (See Fig. 32)

$$\text{Pulse repetition time} = (6.22 - 0.76) \times 2 (\mu\text{s}) = 10.92 \mu\text{s}$$

## USING DELAYED SWEEP FOR MEASUREMENT OF RISETIMES AND FALLTIMES

Risetimes and falltimes are generally measured by using the 10% and 90% amplitude points as reference starting and ending points for the rise or fall.

1. Apply the signal to the INPUT jack and set the vertical MODE to the channel to be used.  
Use the VOLTS/DIV and VARIABLE controls to obtain a normal 6 divisions vertical amplitude waveform.  
Using the POSITION control, set the waveform position in the central area of the screen vertically, that it to coincide with the 100% and 0% lines on the CRT screen.  
Set the SWEEP TIME/DIV control to as high a speed as possible consistent with observatin of both the 10% and 90% points.  
Set the A VARIABLE to CAL position.
2. Set the B MODE to initiate the STARTS AFTER DELAY mode of operation and select the HORIZ DISPLAY to ALT and adjust the B SWEEP TIME/DIV for as short as possible an intensified section of waveform.
3. Using the DELAY TIME MULT, adjust the waveform such that the 10% point is intensified and record the dial reading.
4. Similarly, using the DELAY TIME MULT, adjust the 90% point so that it is intensified and record that dial reading as well.

The pulse risetime (or falltime) is simply the difference between the two dial settings times the A SWEEP TIME/DIV control setting.

Using the formula:

Risetime = (2nd dial reading - 1st dial reading) × Delayed sweep time (A SWEEP TIME/DIV setting)

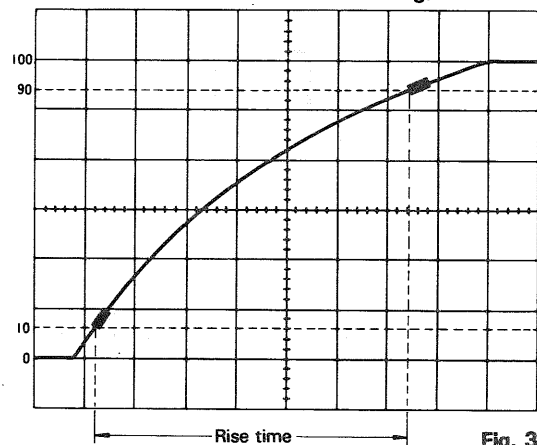

### [EXAMPLE]

For the example, the first dial reading is 1.20 (10% point) and the second is 7.38 (90% point) with the A SWEEP TIME/DIV set at 2  $\mu$ s. (See Fig. 33)

Substituting the given value:

$$\text{Risetime} = (7.38 - 1.20) \times 2 (\mu\text{s}) = 12.36 \mu\text{s}$$

## TIME DIFFERENCE MEASUREMENTS USING DELAYED SWEEP

Synchronized waveforms which are skewed in time can be accurately measured using the delayed sweep.

1. Apply the two signals to the channel 1 and channel 2 INPUT jacks setting the vertical MODE to either ALT or CHOP mode.
2. Set the SOURCE to the signal that is leading in phase and adjust VOLTS/DIV and SWEEP TIME/DIV controls for easy waveform observation.  
Set the A VARIABLE control to CAL position.
3. Set the B MODE to initiate the STARTS AFTER DELAY mode of operation. Set the HORIZ DISPLAY to A. Select the HORIZ DISPLAY to ALT and use the  $\blacktriangle$  TRACE SEP control to adjust the B sweep for easy observation and adjust the B SWEEP TIME/DIV and DELAY TIME MULT controls to make the intensified portion coincide with the rising edge or falling edge of the waveform that is to be used as the reference.
4. Using the DELAY TIME MULT adjust the pulse to any convenient vertical graduation line and record the dial reading at that point.
5. Using the DELAY TIME MULT adjust the corresponding point on the second signal to the same vertical line and record the reading of the dial at this point as well. The time difference or skew of the two waveforms is then the second dial reading minus the first dial reading multiplied by the A SWEEP TIME/DIV control setting.

Using the formula:

$$\text{Time difference} = (2\text{nd dial reading} - 1\text{st dial reading}) \times \text{Delayed sweep time (A SWEEP TIME/DIV setting)}.$$

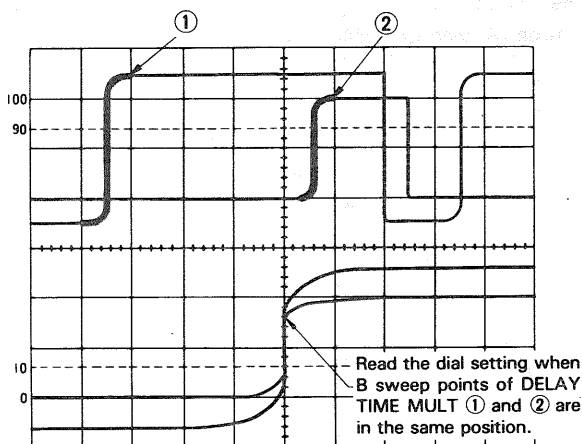

Fig. 34

### [EXAMPLE]

The reference signal dial reading is 1.00 while the second dial reading is 5.34 with an A SWEEP TIME/DIV setting of  $2 \mu\text{s}$ . (See Fig. 34)

Substituting the value:

$$\text{Time difference} = (5.34 - 1.00) \times 2 (\mu\text{s}) = 8.68 \mu\text{s}$$

## X-Y APPLICATIONS

### ★ Phase Shift Measurement

A method of phase measurement requires calculations based on the Lissajous patterns obtained using X-Y operations. Distortion due to non-linear amplification also can be displayed.

A sine wave input is applied to the audio circuit being tested. The same sine wave input is applied to the vertical input of the oscilloscope, and the output of the tested circuit is applied to the horizontal input of the oscilloscope. The amount of phase difference between the two signals can be calculated from the resulting waveform.

To make phase measurements, use the following procedure.

1. Using an audio signal generator with a pure sinusoidal signal, apply a sine wave test signal at the desired test frequency to the audio network being tested.
2. Set the signal generator output for the normal operating level of the circuit being tested. If desired, the circuit's output may be observed on the oscilloscope. If the test circuit is overdriven, the sine wave display on the oscilloscope is clipped and the signal level must be reduced.
3. Connect the channel 2 probe to the output of the test circuit.
4. Select X-Y operation by placing the HORIZ DISPLAY switch in the X-Y position.
5. Connect the channel 1 probe to the input of the test circuit.  
(The input and output test connections to the vertical and horizontal oscilloscope inputs may be reserved.)
6. Adjust the channel 1 and 2 gain controls for a suitable viewing size.
7. Some typical results are shown in Fig. 36.

If the two signals are in phase, the oscilloscope trace is a straight diagonal line. If the vertical and horizontal gain are properly adjusted, this line is at a  $45^\circ$  angle. A  $90^\circ$  phase shift produces a circular oscilloscope pattern. Phase shift of less (or more) than  $90^\circ$  produces an elliptical oscilloscope pattern. The amount of phase shift can be calculated from the oscilloscope trace as shown in Fig. 35.

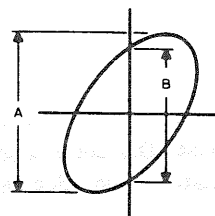

Fig. 35

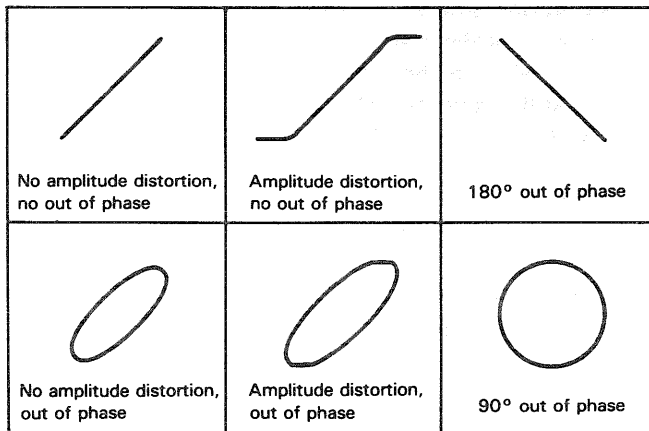

Fig. 36 Typical phase measurement oscilloscope display

★ Frequency Measurement

1. Connect the sine wave of known frequency to the channel 2 INPUT jack of the oscilloscope and select X—Y operation. This provides external horizontal input.
2. Connect the vertical input probe (CH1 INPUT) to the unknown frequency.
3. Adjust the channel 1 and 2 size controls for convenient, easy-to-read size of display.
4. The resulting pattern, called a Lissajous pattern, shows the ratio between the two frequencies.

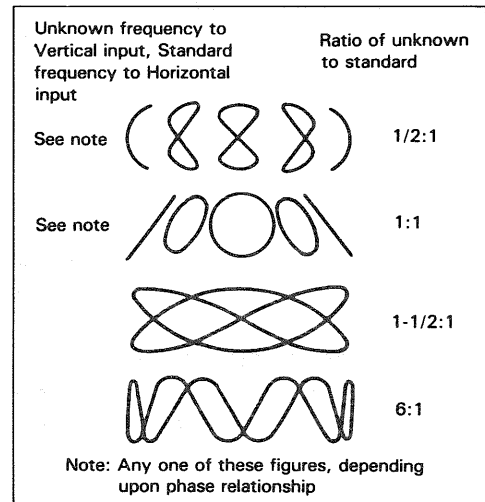

Fig. 37 Lissajous waveforms used for frequency measurement

# ACCESSORIES

## STANDARD ACCESSORIES INCLUDED

Probe (PC-39) .....	Y87-2370-00
Attenuation .....	1/10
Input Impedance .....	10M $\Omega$ , 125pF or less
Instruction Manual .....	B50-7644-10
AC Power Cord .....	Fig. 1

## OPTIONAL ACCESSORIES

Probe Pouch (MC-78).....	Y87-1600-00
Probe Holder.....	J21-2903-03

## MOUNTING THE PROBE POUCH (MC-78)

This soft vinyl pouch attaches to the top side of the oscilloscope housing and provides storage space for two probes and the instruction manual. Install the probe pouch as follows:

1. Unsnap the probe pouch from the retainer plate.
2. Align the retainer plate with the 4 holes on the top side of the case, with the snaps at the top.
3. Attach the four corners of the retainer plate to the oscilloscope case with the four nylon rivets supplied.
4. Attach the probe pouch to the retainer plate using the snap fastener.

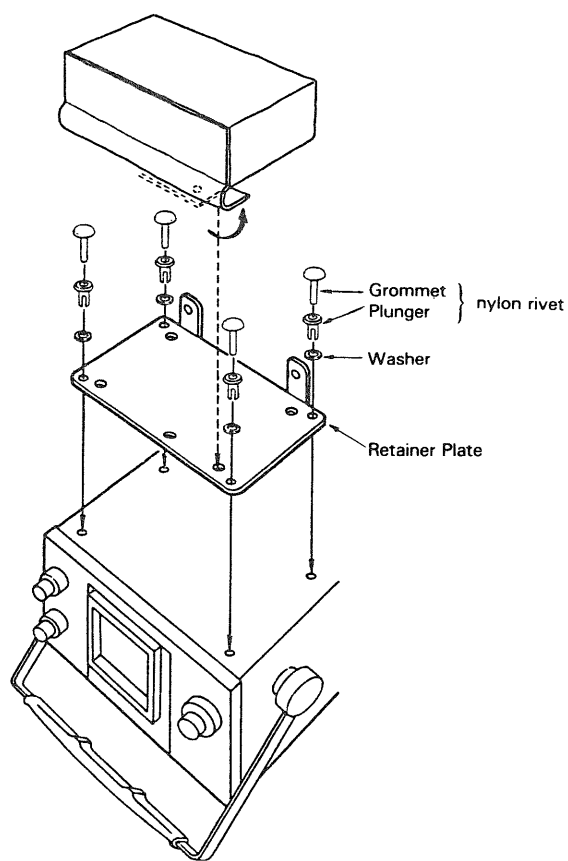

Fig. 38

## INSTALLING PROBE HOLDER

The probe holder is attached to the handle as shown in Fig. 41. Install the probe holder as follows:

1. Rest the upper two claws of the probe holder on the top surface of the handle (see inset).
2. Push lower claws toward handle to lock probe holder in place.
3. Probe can now be inserted into holder.

## CAUTION:

When disengaging the probe holder from handle, disengage lower jaw first to prevent breakage.

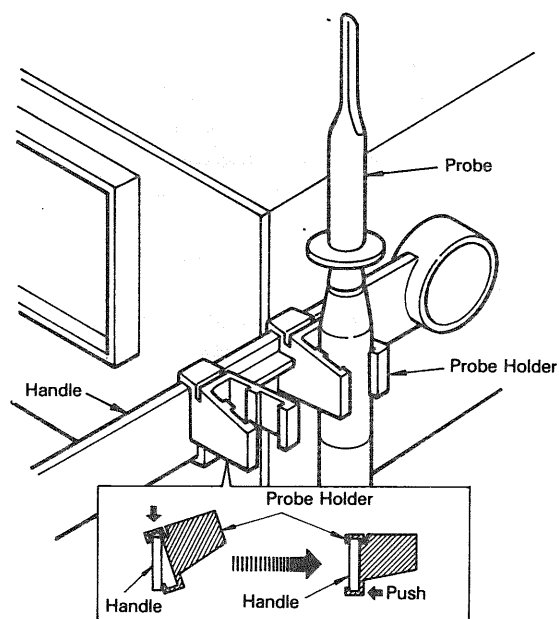

Fig. 39

---

A product of  
**KENWOOD CORPORATION**  
17-5, 2-chome, Shibuya, Shibuya-ku, Tokyo 150, Japan

---

© 96004 PRINTED IN JAPAN B50-7644-10 (N)