



A4-14 ACE-BASS FULLRANGE ACTIVE SPEAKER

Service manual

TABLE OF CONTENTS

	Page
TECHNICAL DESCRIPTION	
Power Supply Circuits	1.1
Automatic ON/OFF	1.2
Overload protection for Midrange and Tweeter	1.3
Signal Amplifier Circuits	2.1 - 3.2
Power Amplifier Circuits	4.1 - 4.2
FAULT FINDING	5.1
ADJUSTMENTS	6.1
PARTS LIST	7-11
CIRCUIT DIAGRAM	
COMPONENT LAYOUT	

1.1 POWER SUPPLY CIRCUITS

Unregulated voltages +30V and -30V supply the Power Amplifier and also a regulator for $\pm 15V$.

-15V supply tracks +15V in order to avoid transients and oscillations when power is switched on or off. The positive supply must decay faster than the negative supply when power is disconnected, which is assured by a 2.2 kohm dummy load (R101) on the +30V capacitor.

1.2 AUTOMATIC ON/OFF

The Auto ON/OFF circuits are powered via D201, D202 and C201. The power transformers and the auto ON/OFF circuits are powered as long as the speaker A4-14 is plugged in to a live outlet. The remaining circuits are powered only in "ON" state when relay K101 is closed.

The audio signals enter via pins 3 and 5 in DIN connector J301. The other A4-14 in a stereo pair receives signals via pins 3 and 5 in DIN connector J302. The signals enter the amplifier circuits via pushbutton switches S301 - S302 which select Left or Right Channel.

The input stage of auto ON/OFF, Z202 (1,2,3) works as amplifier with gain -7 determined by feedback network R204, R205. D208 and D209 limit the amplifier signal to $\pm 7V$. The second stage, Z201 (1,2,3) works as amplifier with gain $\sim 2,000$ at 500 Hz.

The signal at pin 1 is limited to +7.0V/-7V. Z201 (5,6,7) plus transistor V201 works as a schmitt trigger with ON level approx. 7V and OFF level approx. 5V. The input, pin 5, senses a DC voltage which is obtained via diode D211 and capacitor C206.

Transistor V201 drives relay K101, which connects power to the audio circuits in A4-14. When switch S201 is in "AUTO" position, relay K101 will open about 5 minutes after the signal at the input disappeared. The time relay is determined by C206 and R210. During test you may shunt R210 by 100 kohm to obtain shorter OFF-delay.

When switch S201 is in "ON" position, the auto ON/OFF circuits are bypassed and A4-14 remains permanently ON.

A thermistor TS3-75 senses the temperature of the heatsink. When this temperature is too high, the thermistor resistance becomes so low, that relay K101 opens.

1.3 OVERLOAD PROTECTION FOR MIDRANGE AND TWEETER

Z202 (4-13) acts as an overload protection device which is actuated if there is risk for damage to the midrange driver or the tweeter.

The voltage across the voice coils are rectified in diodes D220, D219, and the rectified voltages charge capacitors C212, C211. The time constants for discharge are longer than the charging time constants. If the voltage at Z202 pins 5 or 6 exceeds a threshold value (approx. 3.4V), the mono-stable flip-flop Z202 (8-13) is triggered for 10 seconds. This causes V201 to be shut off, so relay K101 opens and A4-14 is deenergized for 10 seconds.

SIGNAL AMPLIFIER CIRCUITS

2.1 INPUT STAGE

When the Bass-Blend switch is off, the signals enter via R302, C302, R303.

When the Bass-Blend switch is ON, the bass frequency signals in left and right channels are added via filters C301, R301 and R304, C303, R305.

- C301, R301 is a high-pass filter with cutoff frequency 100Hz. Lower frequencies are attenuated by a factor of 2.
- R304, C303, R305 is a low-pass filter with cutoff frequency 100Hz, and attenuation 1:2 relative filter R302, C302, R303.

The signals below 100Hz are summed at Z301, pin 9. Because of the attenuation introduced in each channel, the bass level is the same as when Bass-Blend is not used.

The gain is adjusted by potentiometer R306 in the feedback circuit of operational amplifier number one. After this amplification the signals are split to bass circuits and midrange/tweeter circuits.

2.2 BASS CIRCUITS

The signal passes the bass control circuits R311, Z301 (12,13,14), which controls the signal level to the woofers. The bass control circuits affect higher frequencies (e.g. 100Hz) more than low frequencies (e.g. 30Hz).

The bass signal then passes via a low-pass link R313, C306 which forms one part of the crossover filter between bass and midrange.

The next link is a high-pass filter, which cuts frequencies below 30Hz 12dB/octave, and is part of the woofer's total transfer function.

3.1 ACE-BASS* CIRCUIT

The power amplifier for the woofer, together with Z302 (1,2,3,5,6,7) forms the ACE-BASS*, amplifier, which can be represented by the diagram below

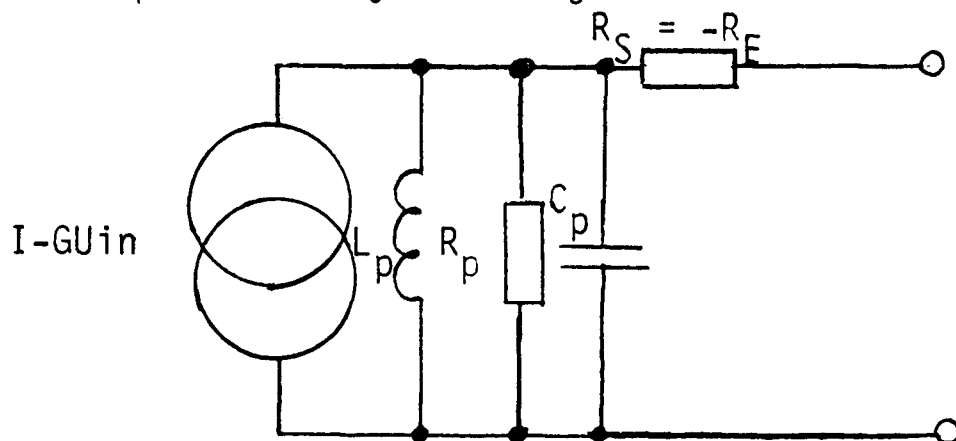

R412 and Z302 (1,2,3) sense the voice coil current in the woofers. Z302 (5,6,7) acts as a band-pass filter and sums signals from (D) and (F).

The power amplifier for the woofer is inverting and acts as adder for signals from (E) and (F).

The part of the current signal (F) which is fed back positively produces the negative output resistance R_S .

The parallel resonant circuit L_p, R_p, C_p is formed by negative feedback of the current signal via the bandpass filter.

*ACE-BASS = Amplifier Controlled Euphonic Bass.

3.2 MIDRANGE AND TREBLE CIRCUITS

From the gain control the signal is also fed to the midrange/treble amplifier. Z301 (5,6,7) acts both as high-pass filter for the crossover (C502, R501, R502) and as treble boost filter (R505, R506, C503). The high-pass link C504, R507, R508 forms the second part of the crossover filter between bass and midrange.

The power amplifier is of the inverting type, and acts as operational amplifier for the treble control R510, which is active above 5kHz.

POWER AMPLIFIER CIRCUITS

4.1 POWER STAGE FOR WOOFERS

The signal is coupled via C703 to the input of the power amplifier.

From the output, the signal is fed back negatively via R 709 and C704. When the signal amplitudes are large, negative feedback also is provided via a network of resistors and diodes. The output signal is compared to the supply voltage, and a couple of volts before clipping will occur, the signal will be rounded by the diode network so the clipping is soft.

The input stage consists of a differential stage V702 and V707 fed via a constant-current generator, V701.

The output stage is of Darlington design with transistors V710-V711 and has AC gain -1. V707 senses the temperature of the output transistors so that the bias current is constant.

V705 and V709 filter the supply voltage for the input stage, eliminating hum and other kinds of noise. (If A4-14 "pops" when switched on, one of these transistors is probably shorted).

No-signal DC-levels of voltages and currents are shown in the circuit diagram enclosed.

To avoid on-and off-transients, the bass amplifier is active only when the supply voltages exceed +17V, so that the operational amplifiers always work properly when the bass amplifier is active. When diode D712 starts conducting, the constant current generator V701 starts working, and via V712 activates even current generator V706. The amplifier is inactive when these current generators are shut off.

4.2 POWER AMPLIFIER FOR MIDRANGE AND TWEETER

The power amplifier is similar to the bass amplifier but the diode network for soft clipping is not included. The voltage-delayed on-function is also eliminated, so this power amplifier is active at low supply voltages.

The signal from the power amplifier is split in passive crossover filters L602, C616, C617 to midrange and C614, C615, L601 to the tweeter.

5.1 FAULT FINDING

A4-14 does not work

1. Set auto ON/OFF in position on
 - 1.1 Check that both the green and red LED are lit.
 - 1.2 Check the power fuses and fuses F601, 602, 701,702.
 - 1.3 Measure supply voltages $+33V \pm 2.5$, $-33V \pm 2.5V$, $+15V \pm 2V$, $-15V \pm 2V$
 - 1.4 To localize the fault, connect test instruments as follows:
 - Tone generator to J301 pins 3 and 5. Adjust till B is 42mV. Sensitivity in Max position, bass and treble pots in center position. Compare to voltage levels according to taylor in circuit diagram.
 - 1.5 If fuses F601, 602, 702 blow during measurement per Section 1.4, you may disconnect the woofers and replace midrange driver and tweeter by 5-10 ohm resistors. Test again per Section 1.4 (signal levels in points (E), (F), (G), (K) and (J) will of course be different).
 - 1.6 Auto ON/OFF can also be tested with set-up per 1.4.
 - Set auto ON/OFF in AUTO.
The signal at Z201 pin 1 should be 7V p-p, and the signal Z201 pin 7 should be 15V DC.
Relay K101 should close at 15mV/500 Hz in
(R210 may be shunted by 100 ohm to reduce the off delay)

ADJUSTMENTS

6.1 BIAS CURRENT IN POWER AMPLIFIERS

After replacing any output transistor in any of the power amplifiers, the bias current must be readjusted. Setting of bias current should be done while heatsinks are at room temperature, that is immediately after A4-14 is turned on.

Set potentiometer R722 or R617 till DC voltage between emitters of V710, V711 or V610, V611 reads 10mV, which corresponds to 23mA bias current.

NOTE: When output transistors are replaced, heat sink compound must be applied to both sides of the insulation washers and to the temperature compensating transistors. Check that insulation is adequate and that the power transistors are mounted flat against the heatsink. The heatsink must be screwed on to the PC card before the transistors are soldered in.

NEGATIVE OUTPUT RESISTANCE

After replacing a woofer, or any of the current sensing resistors R408-R412, the negative output resistance must be re-adjusted.

The woofers must be properly mounted in the cabinet, their voice coils must be connected, and the bass adjustment potentiometer R311 must be in center position. Voice coils must be cold (at room temperature).

Apply an input signal of 60Hz \pm 1Hz and adjust signal generator till test point (G) reads 0dB (= .775V). Change frequency to 180Hz \pm 3Hz without changing the signal level of the signal generator, and set potentiometer R410 till voltage at test point (G) is -7.3dB (7.3dB below 60Hz).

Go back and forth between 60Hz and 180Hz and readjust if required until the difference is stable at 7.3dB.

SPARE PARTS

By referring to component number and artikel number, spare parts can be ordered from general agent or directly from factory.

Lovanger Electronic AB
Fack
930 10 LOVANGER

Tel: 0913-103 00
Telex: 650 43

PARTS LISTING

Contents:

Page

Mechanical Drawings

7

Transistors, Chips, mechanical parts

Diodes, fuses

8

Capacitors

9

Resistors

10-11

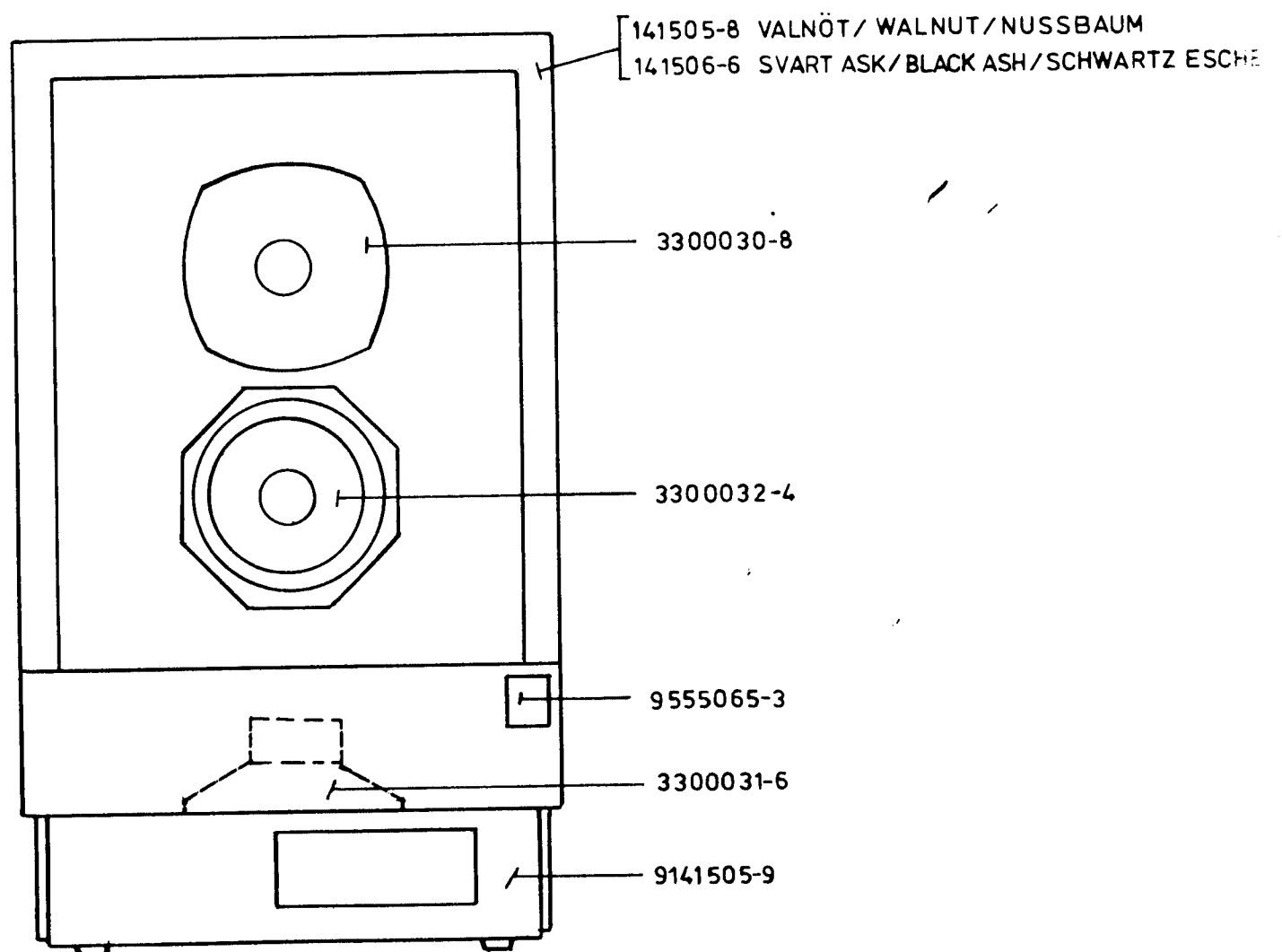
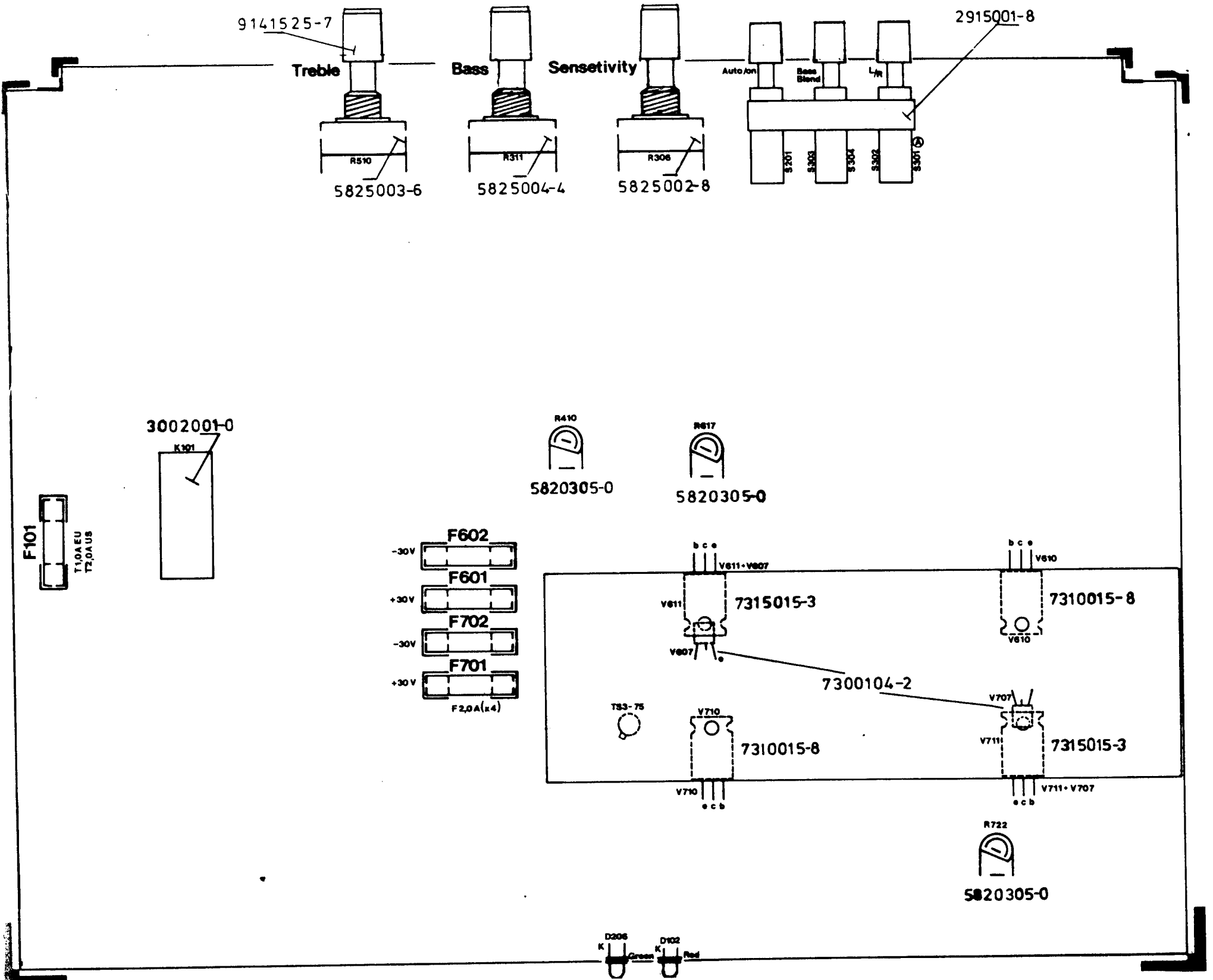

Position	Value	Artikelnummer
R306	100 k (Log)	5825002-8
R311	47 k (Lin)	5825004-4
R410	470	5820305-0
R510	10 k (Lin)	5825003-6
R617	470	5820305-0
R722	470	5820305-0

Termostat	Position	Artikelnummer
TS3-75		3080002-3
Rectifier	D101	7160039-1
Inductor 0,22 mH	L601	6010015-3
Drossel 0,71 mH	L602	6010016-9

Div.	Position	Artikelnummer
Transf. 110V 240V	T101	6065001-7 6065002-5

Transistor
IC

Position Name Artikelnummer

V101	BC546B
V102	BC556B
V103	BC556B
V201	BC546B
V601	BC556B
V602	BC556B
V603	BC556B
V604	BC546
V605	BC546B
V606	BC556
V607	BC546B
V608	BC546
V609	BC556B
V610	BOW930
V611	BOW94B
V701	BC556B
V702	BC556B
V703	BC556B
V704	BC546B
V705	BC546B
V706	BC556
V707	BC546B
V708	BC546B
V709	BC556B
V710	BDW93B
V711	BDW94B
V712	BC546B

Baselern.	3300031-6
Midrange	3300032-4
Tweeter	3300030-8
Knobg Front	9141525-7 9141522-4

Dioder

Position	Artikelnummer	Pos.	Value
D101	LED red	F101	1 AT
D201	IN4004	F701	2 A
D202	IN4004	F702	2 A
D203	Zenerdiod	F601	2 A
D204	IN4148	F602	2 A
D205	Zenerdiod 4,7V		
D206	LED green	7000007-0	
D208	IN4148		
D209	IN4148		
D210	Zenerdiod 6,8V		
D211-214	IN4148		
D215	IN4004		
D216	Zenerdiod 10V		
D217	Zenerdiod 6,8V		
D218-220	IN4148		
D701-711	IN4148		
D712	Zenerdiod 33V		

Z201	TL082CP	6910501-3
Z202	CD4001AE	6840001-9
Z301	TL074CN	6911003-9

Div. Position Artikelnummer

Relay MHPA200	K101	3002001-0
DIN con.	J301	2860102-9
	J302	
Switch Deck	S201	2915001-8
	S301	
	S302	
	S303	
	S304	

Capacitors

Position	F Value	% Tolerans	Artikelnummer	Position	F Value	% Tolerans
C101	47 n			C704	68 p	
C102	47 n			C705	330 p	
C103	4700 μ 40V		5465441-3	C706	0,1 μ	
C104	4700 μ 40V		5465441-3	C707	0,1 μ	
C105	10 63V			C708	47 p	
C106	10 63V			C709	0,1 μ	
C201	100 40V			C710	22 63V	
C202	0,33			C711	22 63V	
C203	4,7 n			C712	0,1 μ	
C204	0,1 μ			C713	0,1 μ	
C205	22 63V			C714	10 63V	
C206	47 63V			C715	10 63V	
C207	0,1 μ			C716	10 n	
C208	0,1 μ					
C209	10 63V					
C210	0,1 μ					
C211	10 63V					
C212	10 63V					
C301	68 n	Polypropylen				
C302	680 p	-"-				
C303	68 n	-"-				
C304	0,47	5	5401522-7			
C305	0,33	5	5401522-7			
C306	0,22	5	5401521-9			
C307	0,1 μ	5	5402517-6			
C308	0,1 μ	5	5402517-6			
C309	0,1 μ					
C310	0,1 μ					
C402	0,15	5				
C403	1,0 μ	5	5401525-0			
C404	1,0 μ					
C405	0,1 μ					
C406	10 n	5	5402571-3			
C407	47 n	5	5402515-0			
C501	33 n	Polypropylen				
C502	33 n	5 -"-				
C503	680 p	5 -"-				
C504	47 n	5 -"-				
C506	47 n	5 -"-				
C601	33 p					
C602	330 p					
C603	0,1 μ					
C604	0,1 μ					
C605	47 p					
C606	0,1 μ					
C607	22					
C608	22 63V					
C609	10 n					
C610	10 n					
C611	10 63V					
C612	10 63V					
C613	10 n					
C701	330 p					
C702	330 p					
C703	10 3V	Tantal				

Resistors

Position	Value	Effekt	Tolerans	Artikelnummer	Position	Value	Effekt	Tolerans	Artikelnummer
R101	2,2k	1/2	5		R401	7,5k	1/8	2	5721494-2
R102	4,7k	1/2	5		R402	390k	1/8	5	
R103	470	1/2	5		R404	22k	1/8	2	5721505-5
R104	33k	1/8	5		R405	4,7k	1/8	2	5721489-2
R105	22k	1/8	5		R406	6,8k	1/8	2	5721493-4
R106	470	1/2	5		R407	12k	1/8	5	
R107	22k	1/8	5		R408	6,8k	1/8	2	5721493-4
R108	18k	1/8	5		R409	10k	1/8	5	
R200	2,2k	1/2	5		R411	1k	1/8	5	
R201	680	1/2	5		R412	0,1	3	5	
R202	4,7M	1/8	5		R501	56k	1/8	2	5721515-4
R203	4,7M	1/8	5		R503	82k	1/8	2	5721495-9
R204	1M	1/8	5		R505	15k	1/8	5	
R205	100k	1/8	5		R506	6,8k	1/8	5	
R206	6,8k	1/8	5		R507	6,8k	1/8	2	5721493-4
R207	100k	1/8	5		R508	82k	1/8	5	
R208	47k	1/8	5		R509	2,2k	1/8	5	
R209	1k	1/8	5		R511	2,7k	1/8	5	
R210	6,8M	1/8	5		R601	47k	1/8	2	5721513-9
R211	100k	1/8	5		R602	4,7k	1/8	5	
R212	33k	1/8	5		R603	470	1/8	5	
R213	33k	1/8	5		R604	100	1/8	5	
R214	33k	1/8	5		R605	1,5k	1/8	5	
R215	1k	1/8	5		R606	100	1/8	5	
R216	820	1/8	5		R607	100k	1/8	5	
R217	220	1/2	5		R608	100k	1/8	5	
R218	10k	1/8	5		R609	47k	1/8	5	
R219	1M	1/8	5		R610	3,3k	1/8	5	
R220	1,5M	1/8	5		R611	680	1/8	5	
R221	1,5M	1/8	5		R611	18k	1/8	5	
R222	330k	1/8	5		R613	68	1/8	5	
R223	220k	1/8	5		R614	4,7k	1/8	5	
R224	270k	1/8	5		R615	4,7k	1/8	5	
R225	150k	1/8	5		R616	1k	1/8	5	
R300	10k	1/8	5		R618	4,7k	1/8	5	
R301	24k	1/8	2	5721506-3	R619	0,22	1	5	5770202-9
R302	12k	1/8	2	5721499-1	R620	0,22	1	5	5770202-9
R303	12k	1/8	2	5721499-1	R621	47	1/2	5	
R304	24k	1/8	2	5721506-3	R701	4,7k	1/8	2	5721489-2
R305	24k	1/8	2	5721506-3	R702	3,3k	1/8	2	5721485-0
R307	18k	1/8	2	5721503-0	R703	33k	1/8	2	5721485-0
R308	18k	1/8	2	5721503-0	R704	4,7k	1/8	2	
R309	10k	1/8	5		R705	22k	1/8	5	
R310	10k	1/8	5		R706	22k	1/8	5	
R313	10k	1/8	2		R707	10k	1/8	5	
R315	36k	1/3	2		R708	10k	1/8	5	
R316	82k	1/8	2						

Resistors

Position	Value	Effekt	Tolerans	Artikelnummer
R709	47k	1/8	2	5721513-9
R710	4,7k	1/8	5	
R711	1k	1/8	5	
R712	1,5k	1/8	5	
R713	100k	1/8	5	
R714	100k	1/8	5	
R715	47k	1/8	5	
R716	3,3k	1/8	5	
R717	680 Ω	1/8	5	
R718	68 Ω	1/8	5	
R719	4,7k	1/8	5	
R720	4,7k	1/8	5	
R721	1k	1/8	5	
R723	4,7k	1/8	5	
R724	0,22 Ω	1	5	
R725	0,22 Ω	1	5	
R726	47 Ω	1/2	5	
R728	6,8k	1/8	5	
R729	1k	1/8	5	

This document must not be copied, either completely or in part, without our permission. Any infringement will lead to legal proceedings.

Material ordered with reference to this specification shall in every respect meet the requirements and data stated herein

Denna handling får ej utan vårt medgivande delas annan, kopieras eller eljest obehörigen användas. Överträdelse härav beivras med stöd av gällande lag.

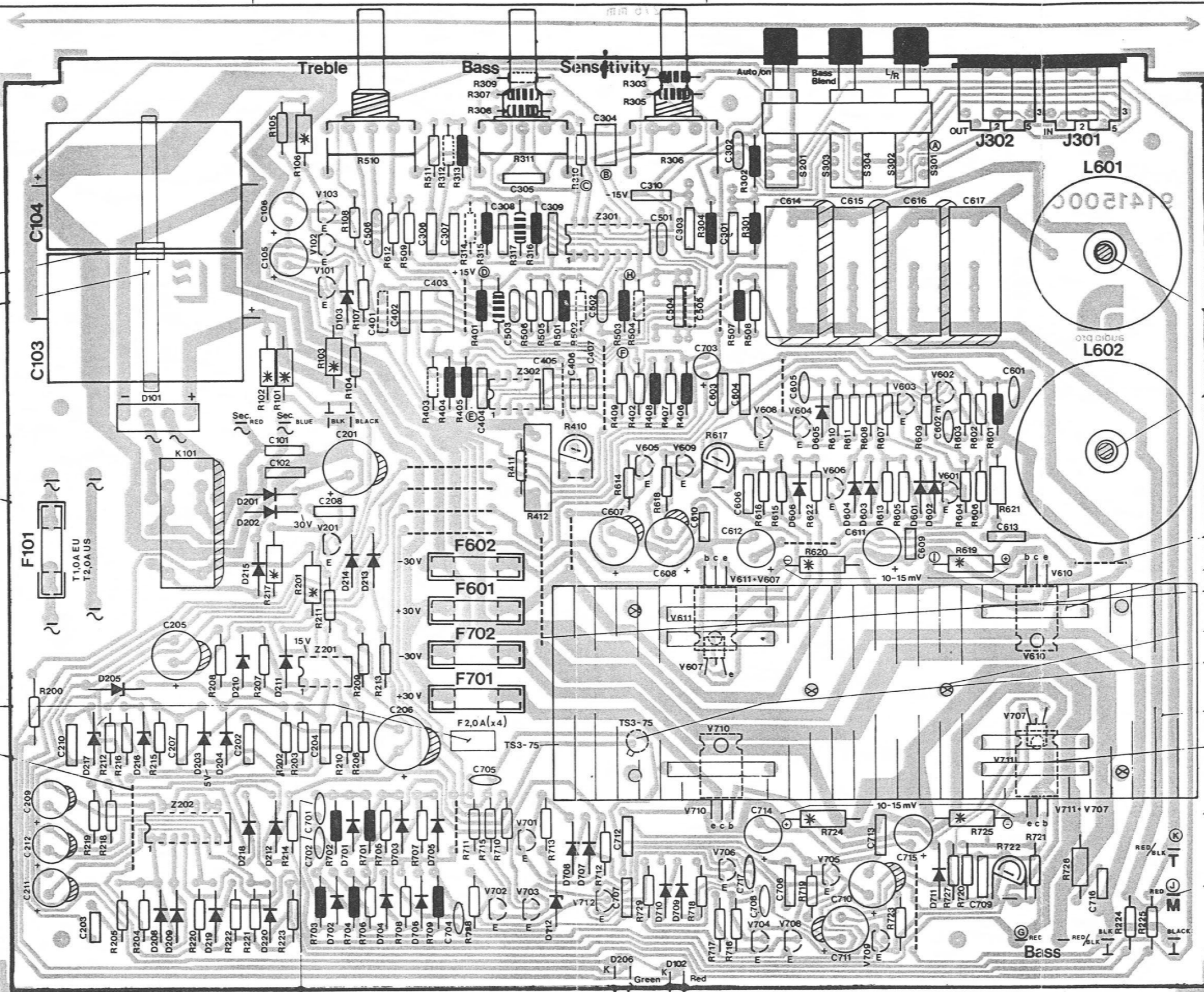

14
4

6

11

8

x 7

16 17

5 x 8

12

10

13

3 7

9

15

1

2

*Monteras upplyftade från kortet (10st motstånd)
 *Install at distance from card (10 resistors)
 R410 R617 R722 låses med lack efter trimning lock with varnish after adjustment

C701 C702 monteras upplyftade och bockade

Limmas med 3140

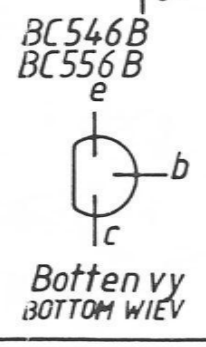
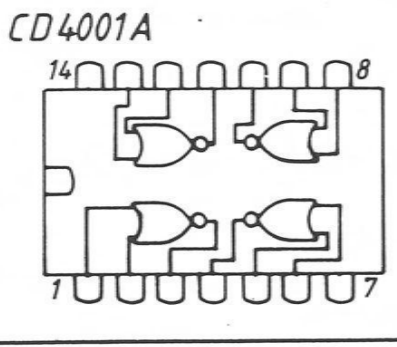
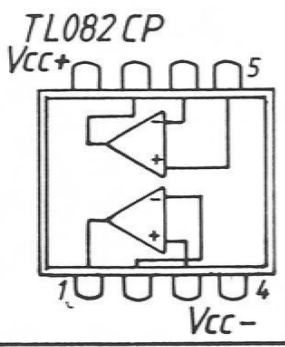
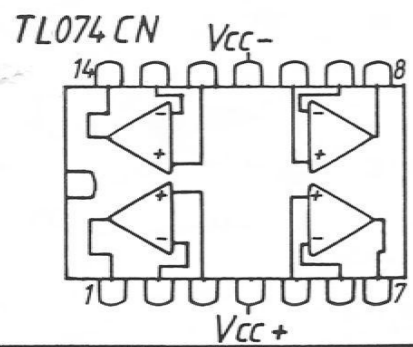

Lövånger Elektronik AB		Uppgjord för/Project	
Ersätter/Replaces	Benämning/Title	audio pro	
Uppgj. sv/Made by	Datum	A4-14	
MG 790827			
Granskad/Checked	Datum		
1 st angle projection	Godkänd/Approved	Scale	Ritningsnummer/Drawing nr
		1:1	790828 Folke Carling 3-141504

This document must not be copied, either completely or in part, without our permission. Any infringement will lead to legal proceedings.

Material ordered with reference to this specification shall in every respect meet the requirements and data stated herein.

Ind. changes in drawings, for details, see Overridelista.

Denna handling innehåller tekniska uppgifter som inte får spridas utan tillstånd från Lövånger Elektronik AB.

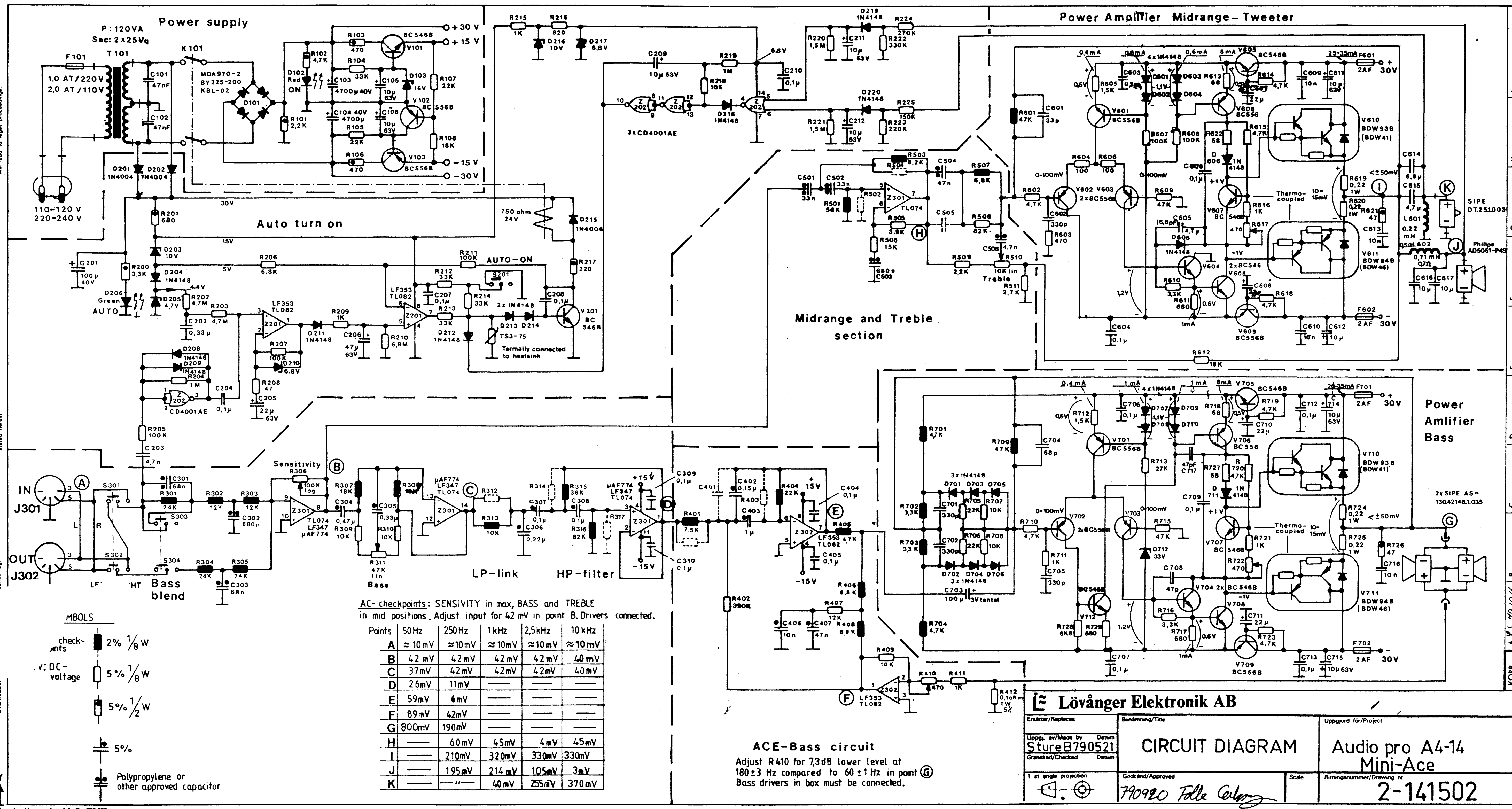

AC- checkpoints: SENSIVITY in max, BASS and TREBLE in mid positions. Adjust input for 42 mV in point B. Drivers connected.

Points	50Hz	250Hz	1kHz	2,5kHz	10kHz
A	≈ 10mV	≈ 10mV	≈ 10mV	≈ 10mV	≈ 10mV
B	42 mV	42 mV	42 mV	42 mV	40 mV
C	37 mV	42 mV	42 mV	42 mV	40 mV
D	2.6 mV	11 mV			
E	59 mV	6 mV			
F	89 mV	42 mV			
G	800 mV	190 mV			
H		60 mV	45 mV	4 mV	45 mV
I		210 mV	320 mV	330 mV	330 mV
J		195 mV	214 mV	105 mV	3 mV
K			40 mV	255 mV	370 mV

ACE-Bass circuit
Adjust R410 for 7,3dB lower level at 180±3 Hz compared to 60±1 Hz in point G
Bass drivers in box must be connected.

Lövånger Elektronik AB

Ersätter/Replaces	Benämning/Titel	Uppgjord för/Project
Uppgj. av/Made by Sture B790521	CIRCUIT DIAGRAM	Audio pro A4-14 Mini-Ace
Granskad/Checked	Scale	Ritningsnummer/Drawing nr 2-141502
1st angle projection	Godkänd/Approved 790920 Folle Colony	