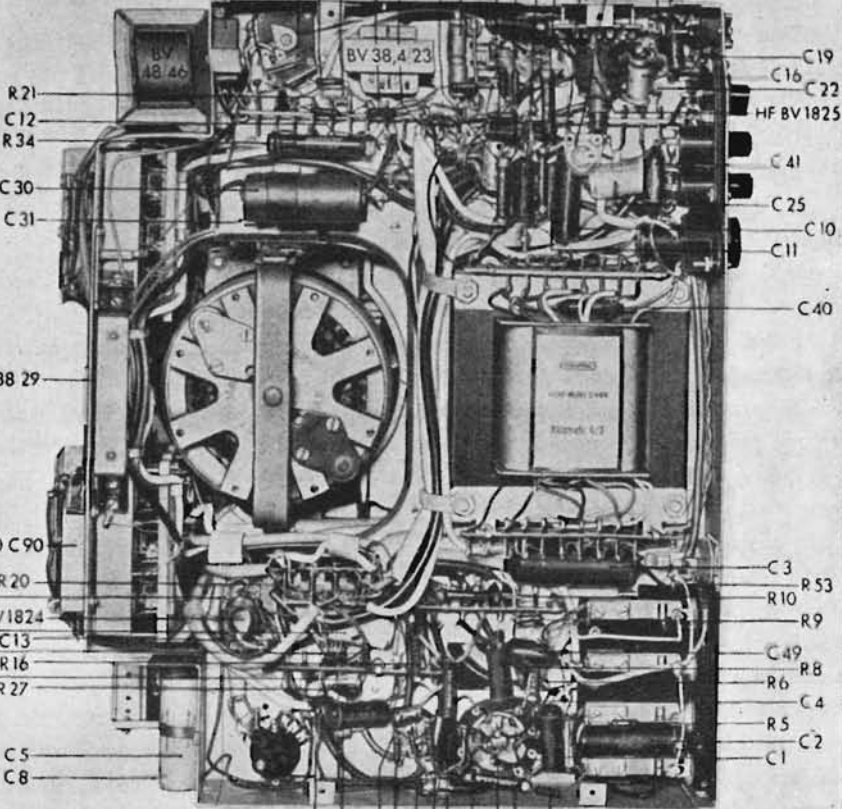

Fig. 15.21. - Schema del registratore a nastro Grundig, mod. TK 819.



R43 R22 C50 R51 C24 R47 R37 R23
B25 C450K L C15 R19 C48 R46 R40 C17



R21
C12
R34
C30
C31

C19
C16
C22
HF BV1825
C41
C25
C10
C11
C40

BV 38 29

B250 C90
R20
C14
HF BV1824
C47 C13
R26 R16
C23 R27

C3
R53
R10
R9
C49
R8
R6
C4
R5
C2
C1

C5
C8

R48 C42 R15 C7 R7 R2
C9 R13 R18 R14 R1