

**harman kardon**

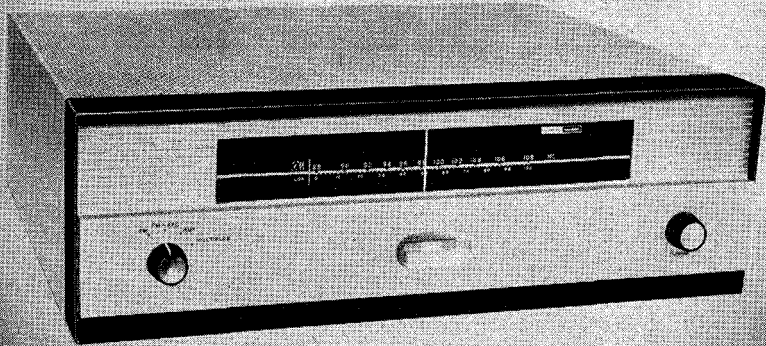

*The Lyric*

MODEL F250

DELUXE FM MULTIPLEX TUNER

## INSTRUCTION MANUAL

It is essential you read this instruction booklet carefully before installing your high fidelity system. You have invested in an extremely fine electronic instrument into which many excellent engineering developments have been incorporated, and each is important for the proper operation of your system. This booklet has been written in simple non-technical language and if you will take the time to read it first before doing anything else, you will find it simple to obtain optimum performance from your Harman-Kardon Model F-250 tuner.

Be sure to keep this booklet available at all times. It contains indispensable technical and service information.



*This is the Harman-Kardon Stereo Symbol. It is your assurance of superb stereo performance.*

## GENERAL DESCRIPTION

The F-250 Deluxe FM tuner is capable of the finest in FM reception. A multiplex adapter, Model MA250, is available for conversion of the F-250 for multiplex stereophonic reception. This adapter, which was specifically designed to be built into the F-250, is based on the Crosby Compatible system of stereo broadcasting, and can be installed by your dealer.

## UNPACKING

After unpacking the Lyric, inspect it carefully for signs of transit damage. The unit was subjected to many inspections and tests at the factory prior to final packing, and it therefore should be in perfect condition. If damage is visible, notify your dealer at once. If the unit was shipped to you, notify the transportation company without delay.

## MAINTENANCE AND REPAIR

Due to the conservative design and high quality components of this instrument, no routine maintenance other than yearly tube-checking is required. Should trouble develop, however, only the most qualified service technician should be employed, as special equipment and training is required to properly service a high fidelity unit. This manual contains information of great value to the repairman, and should be kept available.

Factory Warranty Stations are maintained in most major cities. For the address of the nearest one, or for any other information relating to your Harman-Kardon products, write to the attention of the Customer Service Department, Harman-Kardon, Inc., 520 Main Street, Westbury, N. Y. Be sure to include the model and serial number of the set in question. A short description of your complete installation is often of help in answering your questions.

## WARRANTY POLICY

We urge you to completely fill in your warranty card and mail it to the factory without delay to protect your rights under warranty. The warranty cards are carefully filed for reference and should you require information on the use of this high fidelity unit, or repair service, we will be able to immediately identify your set and reply quickly.

NOTE: It is necessary to receive factory authorization before returning a set for warranty repair either to the factory or to an authorized station. Repairs are to be returned on an Express Prepaid basis. A letter describing the exact difficulty must be enclosed with the unit.

We warrant this instrument to be free from defects in material and workmanship under normal use and service, and in accordance with the conditions herein below set forth, for a period of one year from date of delivery to the original purchaser, and agree to replace or repair any part or parts, with the exception of tubes which are covered by manufacturers' 90 day warranty, returned to us within said one year with transportation prepaid, and which our examination shall disclose to our satisfaction to have been thus defective. This warranty does not include free labor, nor is it applicable to any instrument which shall have been repaired or altered in any way so as in our judgment to affect its stability or reliability nor which has been subject to misuse, neglect, abuse, negligence or accident, nor which has had the serial number altered, effaced or removed. Neither shall this warranty apply to any instrument which has been connected otherwise than in accordance with the instructions furnished by us.

This warranty is expressly in lieu of all other warranties, express or implied, and of all other obligations or liabilities on our part, and we neither assume nor authorize any representative or other person to assume for us any other liability in connection with the sale of this instrument.

# INSTALLATION PROCEDURE

## Ventilation:

The F-250 tuner is well ventilated in itself, but sufficient space must be allowed around it to permit proper air flow. Install the tuner in a manner to allow for unrestricted circulation. When mounting into a cabinet allow at least 3 inches above the tubes. Do not place books or other objects on the cage or in the immediate vicinity of the instrument. Reducing the air flow will result in sharply reduced component and tube life. Caution: When custom installing the tuner do not place it directly over the amplifier. The heat generated by the amplifier may cause deterioration of tuner components and performance.

## Power Requirements:

Plug the AC cord into any outlet furnishing 117 volts, 50 or 60 cycle, AC current. The voltage may vary between 105 and 125 volts. An AC convenience receptacle is located on the rear panel and is controlled by the on/off switch.

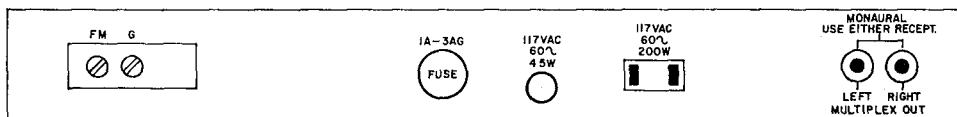

## REAR PANEL CONNECTIONS

### Audio Output:

Two AUDIO OUTPUT receptacles are located on the rear of the chassis. They are used to connect the tuner to the amplifier for either monaural FM operation or for stereo multiplex.

### Connecting for FM Monaural Operation:

To operate the F-250 as a conventional monaural tuner connect a shielded lead between either AUDIO OUTPUT receptacle and the Tuner or Aux input receptacle on your amplifier. This will permit FM operation as selected by the FUNCTION switch on the front panel.

### Connecting for Stereo Multiplex Operation:

To operate the F-250—MA250 for either conventional monaural FM reception or for multiplex stereo, connect a shielded lead between each of the two AUDIO OUTPUT receptacles and the two TUNER input receptacles of your stereo amplifier. This will permit FM or FM stereo operation, as selected by the FUNCTION switch on the front panel.

### Connecting the FM Antenna:

Due to the high FM sensitivity of the F-250 tuner, the 48" piece of wire supplied with the set will be sufficient antenna for all but the most difficult locations. One end of this wire should be fastened to the FM terminal on the Antenna Terminal Strip, and the other end left free and extended as may be convenient. It may be tacked or stapled to the rear of the bookcase or equipment cabinet, if necessary.

If an outdoor antenna is needed, use a folded dipole or Yagi, cut for the FM band. While a TV antenna is at times acceptable, for the best possible reception an FM antenna should be used. Attach the 300 ohm lead-in wire to terminals FM and G on the rear of the F-250 tuner.

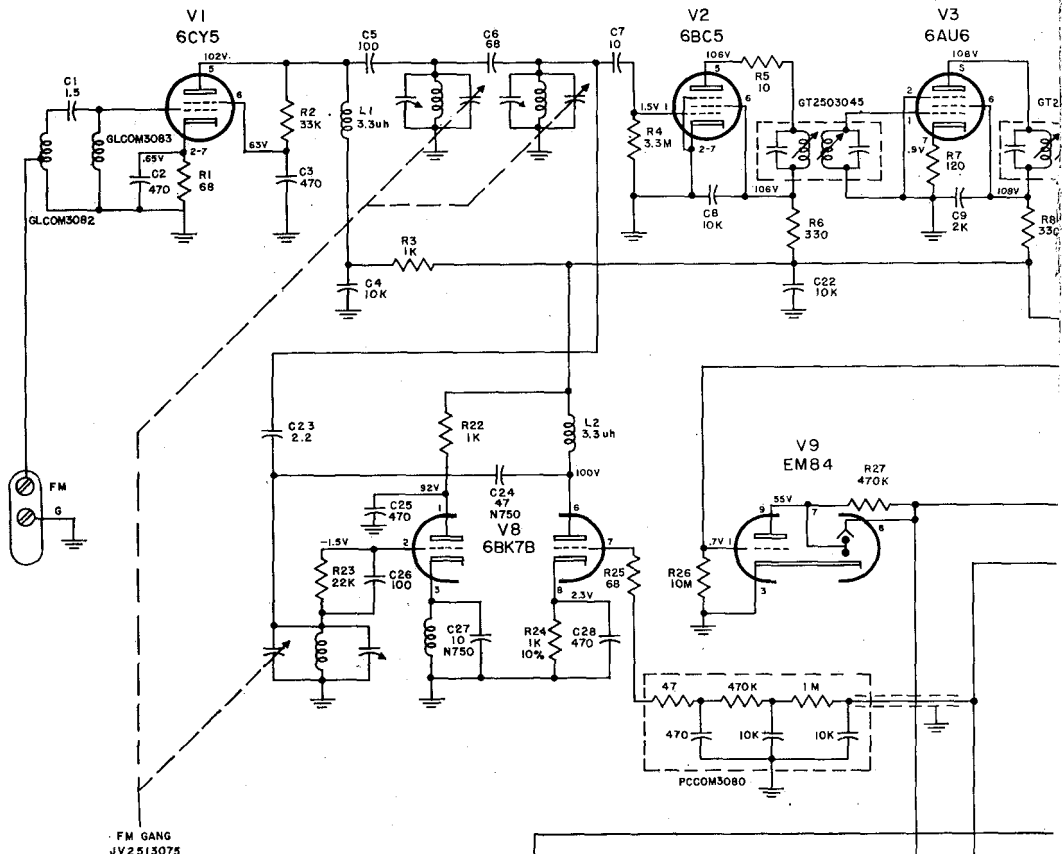

FM GANG  
JV2513075

MULTIPLEX  
ADAPTOR  
SOCKET

ER2513079 FUNCTION S1  
SHOWN IN POS. 1.

- POS. 1 OFF
- 2. FM
- 3. FM/AF/C
- 4. MULTIP

\* RESISTANCE CHART

TUBE	1	2	3	4	5	6	7	8	9
V1 6CY5	0	68	—	—	>20K	>20K	68	—	—
V2 6BC5	3.3M	0	—	—	>20K	>20K	0	—	—
V3 6AU6	0	0	—	—	>20K	>20K	120	—	—
V4 6BA6	0	0	—	—	>20K	>20K	120	—	—
V5 6AU6	100K	0	—	—	>20K	>20K	120	—	—
V6 6BN6	220	0	—	—	>20K	3.3K	>20K	—	—
V7 6AL5	0	100K	—	—	180K	—	100K	—	—
V8 6BK7B	>20K	22K	0	—	>20K	550K	1K	—	—
V9 EM84	10M	0	0	—	>20K	>20K	>20K	—	—
V10 12AU7	>20K	1.1M	105K	—	>20K	1.1M	105K	—	—

NOTE

UNLESS OTHERWISE SHOWN:  
ALL RESISTORS 1/2 WATT 20%.  
ALL CAPACITORS WITH DECIMAL  
POINT TO BE PAPER IN MFD.  
ALL CAPACITORS WITHOUT DECIMAL  
TO BE GENERAL PURPOSE CERAMIC  
500WVDC 20% IN MMF.  
ALL VOLTAGES ARE DC.  
ALL RESISTANCES ARE IN OHMS.  
VOLTAGES OF V10 MARKED Ø ARE  
MEASURED WITH RESPECT TO CATHODE.

S251  
S2513176 A

\* VOLTAGE & RESISTANCE READINGS, FUNCTION SWITCH IN FM POS.  
WITH NO SIGNAL INPUT.

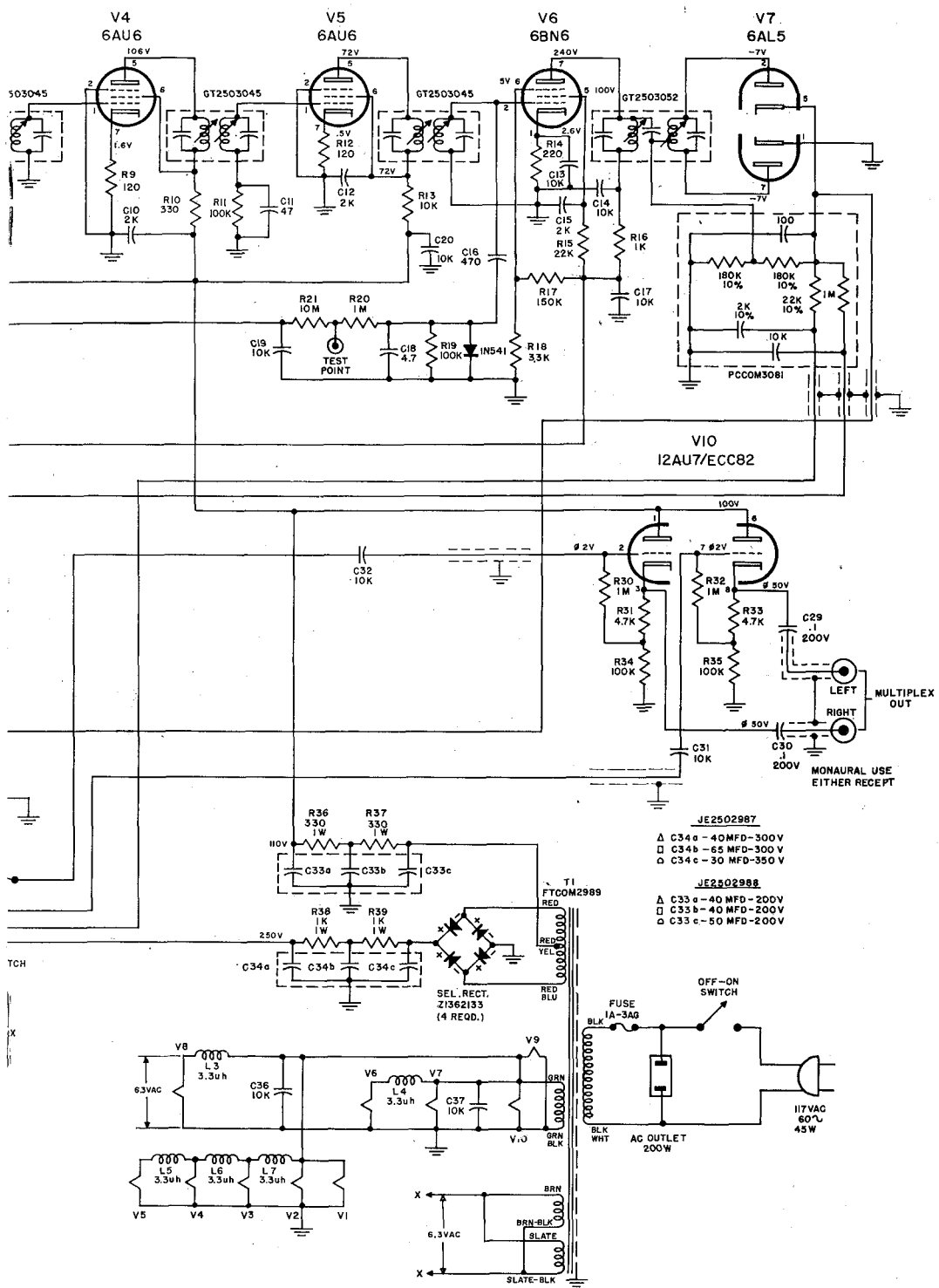

**JE2502987**

- △ C34a - 40MFD-300V
- C34b - 65 MFD-300V
- C34c - 30 MFD-350V

**JE2502988**

- △ C33a - 40 MFD - 200V
- C33b - 40 MFD-200V
- C33c - 50 MFD-200V

SEL. RECT.  
Z1362133  
(4 REQD.)

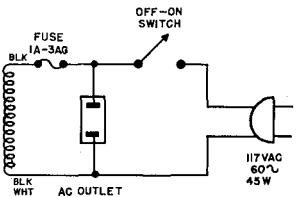

TCH

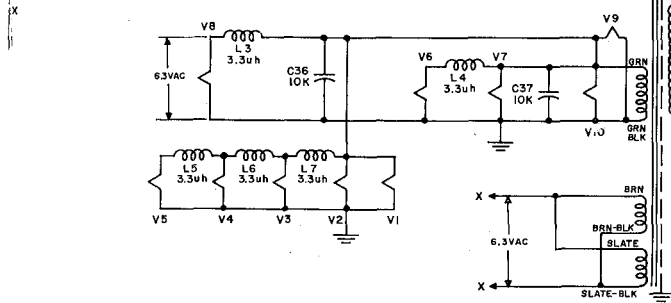

## OPERATING INSTRUCTIONS

The F-250 incorporates the following operating controls located on the front panel. Viewing the instrument from left to right you will note the **FUNCTION SELECTOR** switch (OFF, FM, FM-AFC, MULTIPLEX) to select the desired type of program source, and the **TUNING** control to select FM stations.

### To Receive Monaural Programs:

Turn the **FUNCTION SELECTOR** switch to the FM or FM-AFC position. FM stations may now be tuned with the station **TUNING** control.

### To Receive Stereophonic Programs:

Reception of FM-Multiplex stereophonic programs with the Model F-250—MA250 is simple and uncomplicated. Set the **FUNCTION** switch to FM, and tune to the desired FM-Multiplex station. Now set the **FUNCTION** switch to the FM-MULTI position. Adjust the **DIMENSION** control for maximum stereo effect. You will notice that when this control is turned to the extreme counter-clockwise position, monaural reception results. As the **DIMENSION** control is turned in a clockwise direction, the stereo effect will be introduced, and will reach a maximum. After reaching this point, the stereo effect will diminish, and the tonal balance will change. The setting for maximum stereo effect is fairly broad, and may vary for different stations.

## TECHNICAL EXPLANATION OF THE CONTROLS

### Function Selector Switch:

This switch incorporates four positions.

1. "OFF" turns the tuner power off.
2. "FM" selects the FM tuner for operation.
3. "FM-AFC" selects the FM tuner for operation with the addition of automatic frequency control.
4. "MULTIPLEX" selects the stereo multiplex adapter for operation.

### Automatic Frequency Control: (AFC)

FM Broadcasting, by its very nature, eliminates almost all natural and man-made static. However, the characteristics of FM which makes this possible also causes problems in tuning. The Lyric incorporates a special electronic circuit known as Automatic Frequency Control that overcomes these problems and insures proper tuning even if the manual tuning is not accurately done. Therefore AFC always keeps the station in the center of the channel and eliminates distortion caused by inaccurate tuning.

The following experiment will lead to an understanding of AFC, and the fuller enjoyment of the Lyric, Model F-250 tuner.

Tune across the FM scale with the **FUNCTION** Switch in the FM-AFC position. Note how the stations "pop" into place. Now tune to any station, preferably one with a musical program. Defeat the AFC by turning the **FUNCTION SELECTOR** Switch to the FM position, and tune slowly through the station from left to right. Notice there are three distinct points where the station sounds clear, interspersed with points of distorted sound. The middle clear-sounding point is the proper tuning position for the best tone quality with minimum noise and interference. Detune the station so that the sound is distorted. Now turn the **FUNCTION SELECTOR** Switch to the FM-AFC position, and notice how the sound clears up.

The tuning has been readjusted by the operation of the AFC circuit, which automatically retunes the electronic circuits to the center of the station channel.

In order to take maximum advantage of the benefits of AFC, it is suggested that fine tuning be done with the FUNCTION Switch in the FM position. When the switch is then turned to the AFC position the AFC will improve this careful tuning by a factor of 10 to 1. The procedure is especially recommended when a weak station is being tuned on a channel adjacent to a stronger one. This will prevent the AFC from reaching for the powerful signal and skipping over the weaker one. If the weaker station is tuned in without the AFC, when the AFC is applied it will lock it in permanently.

### **Tuning Indicator:**

The F-250 incorporates a unique tuning indicator which operates on the FM band to insure accurate tuning. Optimum tuning occurs when green bars are largest, and the dark space between is at a minimum.

## **ADJUSTMENTS**

In some installations, hum may be encountered due to a voltage difference between the amplifier, tuner and record changer chassis. This may be eliminated by reversing one or all of the AC power plugs. Simply reverse one at a time until improvement is experienced.

## **MAINTENANCE AND REPAIRS**

### **Fuse:**

In the event of a potentially damaging failure of tubes or components, the Model F-250 is protected by a 1 ampere, type 3AG fuse, located on the rear of the unit. If this fuse is blown, it should be replaced only with one of the same rating. Replacing with a fuse of higher rating will not protect the amplifier, and may result in severe damage, which will not be covered by the factory warranty.

### **Routine Maintenance:**

Due to the conservative design and high quality components of the Model F-250, no routine maintenance other than yearly tube checking is advised.

### **Repair:**

Only the most qualified service technician should be employed, as special equipment and training is required to properly service a high fidelity instrument. This manual contains information of great value to the repairman, and should be kept available.

Factory Warranty Stations are maintained in most major cities. For the address of the nearest one, or for any other information relating to your Harman-Kardon products, write to the attention of the Customer Service Department, Harman-Kardon, Inc., 520 Main St., Westbury, N. Y. Be sure to include the model and serial number of the set in question. A short description of your complete installation is often of help in answering your questions.

