

AD565A*/AD566A*

FEATURES

- Single Chip Construction**
- Very High-Speed Settling to 1/2 LSB**
 - AD565A: 250 ns max
 - AD566A: 350 ns max
- Full-Scale Switching Time: 30 ns**
- Guaranteed for Operation with ± 12 V Supplies:**
 - AD565A with -12 V Supply: AD566A
- Linearity Guaranteed Over Temperature:**
 - 1/2 LSB max (K, T Grades)
- Monotonicity Guaranteed Over Temperature**
- Low Power: AD566A = 180 mW max;**
 - AD565A = 225 mW max
- Use with On-Board High-Stability Reference (AD565A)
or with External Reference (AD566A)**
- Low Cost**
- MIL-STD-883-Compliant Versions Available**

PRODUCT DESCRIPTION

The AD565A and AD566A are fast 12-bit digital-to-analog converters which incorporate the latest advances in analog circuit design to achieve high speeds at low cost.

The AD565A and AD566A use 12 precision, high-speed bipolar current-steering switches, control amplifier and a laser-trimmed thin-film resistor network to produce a very fast, high accuracy analog output current. The AD565A also includes a buried Zener reference that features low-noise, long-term stability and temperature drift characteristics comparable to the best discrete reference diodes.

The combination of performance and flexibility in the AD565A and AD566A has resulted from major innovations in circuit design, an important new high-speed bipolar process, and continuing advances in laser-wafer-trimming techniques (LWT). The AD565A and AD566A have a 10–90% full-scale transition time less than 35 ns and settle to within $\pm 1/2$ LSB in 250 ns max (350 ns for AD566A). Both are laser-trimmed at the wafer level to $\pm 1/8$ LSB typical linearity and are specified to $\pm 1/4$ LSB max error (K and T grades) at $+25^\circ\text{C}$. High speed and accuracy make the AD565A and AD566A the ideal choice for high-speed display drivers as well as fast analog-to-digital converters.

The laser trimming process which provides the excellent linearity is also used to trim both the absolute value and the temperature coefficient of the reference of the AD565A resulting in a typical full-scale gain TC of 10 ppm/ $^\circ\text{C}$. When tighter TC performance is required or when a system reference is available, the AD566A may be used with an external reference.

*Covered by Patent Nos.: 3,803,590; RE 28,633; 4,213,806; 4,136,349; 4,020,486; 3,747,088.

REV. C

Information furnished by Analog Devices is believed to be accurate and reliable. However, no responsibility is assumed by Analog Devices for its use, nor for any infringements of patents or other rights of third parties which may result from its use. No license is granted by implication or otherwise under any patent or patent rights of Analog Devices.

FUNCTIONAL BLOCK DIAGRAM

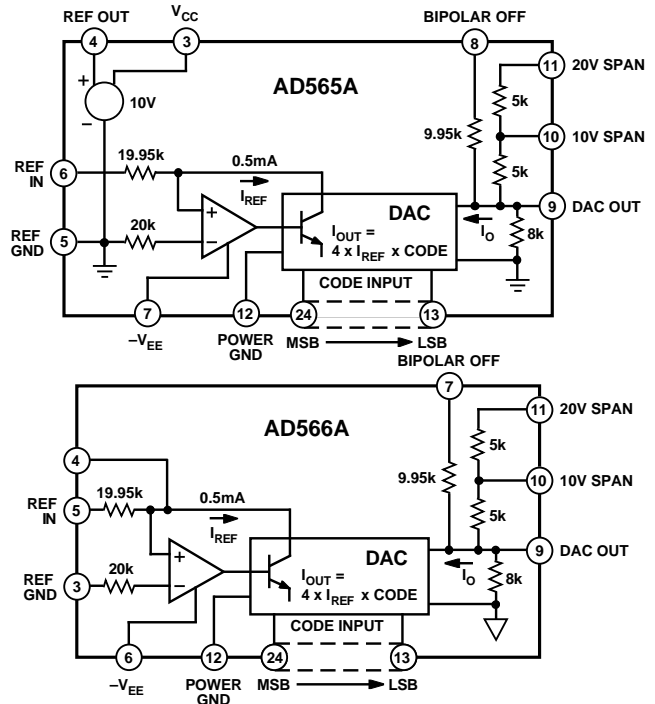

AD565A and AD566A are available in four performance grades. The J and K are specified for use over the 0°C to $+70^\circ\text{C}$ temperature range while the S and T grades are specified for the -55°C to $+125^\circ\text{C}$ range. The D grades are all packaged in a 24-pin, hermetically sealed, ceramic, dual-in-line package. The JR grade is packaged in a 28-pin plastic SOIC.

PRODUCT HIGHLIGHTS

1. The wide output compliance range of the AD565A and AD566A are ideally suited for fast, low noise, accurate voltage output configurations without an output amplifier.
2. The devices incorporate a newly developed, fully differential, nonsaturating precision current switching cell structure which combines the dc accuracy and stability first developed in the AD562/3 with very fast switching times and an optimally-damped settling characteristic.
3. The devices also contain SiCr thin film application resistors which can be used with an external op amp to provide a precision voltage output or as input resistors for a successive approximation A/D converter. The resistors are matched to the internal ladder network to guarantee a low gain temperature coefficient and are laser-trimmed for minimum full-scale and bipolar offset errors.

AD565A—SPECIFICATIONS (T_A = +25°C, V_{CC} = +15 V, V_{EE} = +15 V, unless otherwise noted.)

Model	AD565AJ			AD565AK			Units
	Min	Typ	Max	Min	Typ	Max	
DATA INPUTS¹ (Pins 13 to 24)							
TTL or 5 Volt CMOS							
Input Voltage							
Bit ON Logic "1"	+2.0		+5.5	+2.0		+5.5	V
Bit OFF Logic "0"			+0.8			+0.8	V
Logic Current (Each Bit)							
Bit ON Logic "1"		+120	+300		+120	+300	μA
Bit OFF Logic "0"		+35	+100		+35	+100	μA
RESOLUTION			12			12	Bits
OUTPUT							
Current							
Unipolar (All Bits On)	-1.6	-2.0	-2.4	-1.6	-2.0	-2.4	mA
Bipolar (All Bits On or Off)	±0.8	±1.0	±1.2	±0.8	±1.0	±1.2	mA
Resistance (Exclusive of Span Resistors)	6k	8k	10k	6k	8k	10k	Ω
Offset							
Unipolar		0.01	0.05		0.01	0.05	% of F.S. Range
Bipolar (Figure 3, R ₂ = 50 Ω Fixed)		0.05	0.15		0.05	0.1	% of F.S. Range
Capacitance		25			25		pF
Compliance Voltage							
T _{MIN} to T _{MAX}	-1.5		+10	-1.5		+10	V
ACCURACY (Error Relative to Full Scale) +25°C							
		±1/4 (0.006)	±1/2 (0.012)		±1/8 (0.003)	±1/4 (0.006)	LSB % of F.S. Range
T _{MIN} to T _{MAX}		±1/2 (0.012)	±3/4 (0.018)		±1/4 (0.006)	±1/2 (0.012)	LSB % of F.S. Range
DIFFERENTIAL NONLINEARITY +25°C							
T _{MIN} to T _{MAX}		±1/2	±3/4		±1/4	±1/2	LSB
		MONOTONICITY GUARANTEED			MONOTONICITY GUARANTEED		
TEMPERATURE COEFFICIENTS							
With Internal Reference							
Unipolar Zero		1	2		1	2	ppm/°C
Bipolar Zero		5	10		5	10	ppm/°C
Gain (Full Scale)		15	50		10	20	ppm/°C
Differential Nonlinearity		2			2		ppm/°C
SETTLING TIME TO 1/2 LSB							
All Bits ON-to-OFF or OFF-to-ON		250	400		250	400	ns
FULL-SCALE TRANSITION							
10% to 90% Delay plus Rise Time		15	30		15	30	ns
90% to 10% Delay plus Fall Time		30	50		30	50	ns
TEMPERATURE RANGE							
Operating	0		+70	0		+70	°C
Storage	-65		+150	-65		+150	°C
POWER REQUIREMENTS							
V _{CC} , +11.4 to +16.5 V dc		3	5		3	5	mA
V _{EE} , -11.4 to -16.5 V dc		-12	-18		-12	-18	mA
POWER SUPPLY GAIN SENSITIVITY²							
V _{CC} = +11.4 to +16.5 V dc		3	10		3	10	ppm of F.S./%
V _{EE} = -11.4 to -16.5 V dc		15	25		15	25	ppm of F.S./%
PROGRAMMABLE OUTPUT RANGES (see Figures 2, 3, 4)							
		0 to +5			0 to +5		V
		-2.5 to +2.5			-2.5 to +2.5		V
		0 to +10			0 to +10		V
		-5 to +5			-5 to +5		V
		-10 to +10			-10 to +10		V
EXTERNAL ADJUSTMENTS							
Gain Error with Fixed 50 Ω Resistor for R2 (Figure 2)		±0.1	±0.25		±0.1	±0.25	% of F.S. Range
Bipolar Zero Error with Fixed 50 Ω Resistor for R1 (Figure 3)		±0.05	±0.15		±0.05	±0.1	% of F.S. Range
Gain Adjustment Range (Figure 2)	±0.25			±0.25			% of F.S. Range
Bipolar Zero Adjustment Range	±0.15			±0.15			% of F.S. Range
REFERENCE INPUT							
Input Impedance	15k	20k	25k	15k	20k	25k	Ω
REFERENCE OUTPUT							
Voltage	9.90	10.00	10.10	9.90	10.00	10.10	V
Current (Available for External Loads) ³	1.5	2.5		1.5	2.5		mA
POWER DISSIPATION		225	345		225	345	mW

NOTES

¹The digital inputs are guaranteed but not tested over the operating temperature range.

²The power supply gain sensitivity is tested in reference to a V_{CC}, V_{EE} of ±15 V dc.

³For operation at elevated temperatures the reference cannot supply current for external loads. It, therefore, should be buffered if additional loads are to be supplied. Specifications subject to change without notice.

AD565A/AD566A

Model	AD565AS			AD565AT			Units
	Min	Typ	Max	Min	Typ	Max	
DATA INPUTS ¹ (Pins 13 to 24)							
TTL or 5 Volt CMOS							
Input Voltage							
Bit ON Logic "1"	+2.0		+5.5	+2.0		+5.5	V
Bit OFF Logic "0"			+0.8			+0.8	V
Logic Current (Each Bit)							
Bit ON Logic "1"		+120	+300		+120	+300	μA
Bit OFF Logic "0"		+35	+100		+35	+100	μA
RESOLUTION			12			12	Bits
OUTPUT							
Current							
Unipolar (All Bits On)	-1.6	-2.0	-2.4	-1.6	-2.0	-2.4	mA
Bipolar (All Bits On or Off)	±0.8	±1.0	±1.2	±0.8	±1.0	±1.2	mA
Resistance (Exclusive of Span Resistors)	6k	8k	10k	6k	8k	10k	Ω
Offset							
Unipolar		0.01	0.05		0.01	0.05	% of F.S. Range
Bipolar (Figure 3, R ₂ = 50 Ω Fixed)		0.05	0.15		0.05	0.1	% of F.S. Range
Capacitance		25			25		pF
Compliance Voltage							
T _{MIN} to T _{MAX}	-1.5		+10	-1.5		+10	V
ACCURACY (Error Relative to Full Scale) +25°C							
T _{MIN} to T _{MAX}		±1/4 (0.006)	±1/2 (0.012)		±1/8 (0.003)	±1/4 (0.006)	LSB % of F.S. Range
		±1/2 (0.012)	±3/4 (0.018)		±1/4 (0.006)	±1/2 (0.012)	LSB % of F.S. Range
DIFFERENTIAL NONLINEARITY +25°C							
T _{MIN} to T _{MAX}		±1/2	±3/4		±1/4	±1/2	LSB
		MONOTONICITY GUARANTEED			MONOTONICITY GUARANTEED		
TEMPERATURE COEFFICIENTS							
With Internal Reference							
Unipolar Zero		1	2		1	2	ppm/°C
Bipolar Zero		5	10		5	10	ppm/°C
Gain (Full Scale)		15	30		10	15	ppm/°C
Differential Nonlinearity		2			2		ppm/°C
SETTLING TIME TO 1/2 LSB							
All Bits ON-to-OFF or OFF-to-ON		250	400		250	400	ns
FULL-SCALE TRANSITION							
10% to 90% Delay plus Rise Time		15	30		15	30	ns
90% to 10% Delay plus Fall Time		30	50		30	50	ns
TEMPERATURE RANGE							
Operating	-55		+125	-55		+125	°C
Storage	-65		+150	-65		+150	°C
POWER REQUIREMENTS							
V _{CC} , +11.4 to +16.5 V dc		3	5		3	5	mA
V _{EE} , -11.4 to -16.5 V dc		-12	-18		-12	-18	mA
POWER SUPPLY GAIN SENSITIVITY ²							
V _{CC} = +11.4 to +16.5 V dc		3	10		3	10	ppm of F.S./%
V _{EE} = -11.4 to -16.5 V dc		15	25		15	25	ppm of F.S./%
PROGRAMMABLE OUTPUT RANGES (see Figures 2, 3, 4)							
		0 to +5			0 to +5		V
		-2.5 to +2.5			-2.5 to +2.5		V
		0 to +10			0 to +10		V
		-5 to +5			-5 to +5		V
		-10 to +10			-10 to +10		V
EXTERNAL ADJUSTMENTS							
Gain Error with Fixed 50 Ω Resistor for R ₂ (Figure 2)		±0.1	±0.25		±0.1	±0.25	% of F.S. Range
Bipolar Zero Error with Fixed 50 Ω Resistor for R ₁ (Figure 3)		±0.05	±0.15		±0.05	±0.1	% of F.S. Range
Gain Adjustment Range (Figure 2)	±0.25			±0.25			% of F.S. Range
Bipolar Zero Adjustment Range	±0.15			±0.15			% of F.S. Range
REFERENCE INPUT							
Input Impedance	15k	20k	25k	15k	20k	25k	Ω
REFERENCE OUTPUT							
Voltage	9.90	10.00	10.10	9.90	10.00	10.10	V
Current (Available for External Loads) ³	1.5	2.5		1.5	2.5		mA
POWER DISSIPATION		225	345		225	345	mW

Specifications shown in boldface are tested on all production units at final electrical test. Results from those tests are used to calculate outgoing quality levels. All min and max specifications are guaranteed, although only those shown in boldface are tested on all production units.

AD566A—SPECIFICATIONS ($T_A = +25^\circ\text{C}$, $V_{EE} = -15\text{ V}$, unless otherwise noted)

Model	AD566AJ			AD566AK			Units
	Min	Typ	Max	Min	Typ	Max	
DATA INPUTS ¹ (Pins 13 to 24) TTL or 5 Volt CMOS							
Input Voltage							
Bit ON Logic "1"	+2.0		+5.5	+2.0		+5.5	V
Bit OFF Logic "0"	0		+0.8	0		+0.8	V
Logic Current (Each Bit)							
Bit ON Logic "1"		+120	+300		+120	+300	μA
Bit OFF Logic "0"		+35	+100		+35	+100	μA
RESOLUTION			12			12	Bits
OUTPUT							
Current							
Unipolar (All Bits On)	-1.6	-2.0	-2.4	-1.6	-2.0	-2.4	mA
Bipolar (All Bits On or Off)	± 0.8	± 1.0	± 1.2	± 0.8	± 1.0	± 1.2	mA
Resistance (Exclusive of Span Resistors)	6k	8k	10K	6k	8k	10k	Ω
Offset							
Unipolar (Adjustable to Zero per Figure 3)		0.01	0.05		0.01	0.05	% of F.S. Range
Bipolar (Figure 4, R_1 and $R_2 = 50\ \Omega$ Fixed)		0.05	0.15		0.05	0.1	% of F.S. Range
Capacitance		25			25		pF
Compliance Voltage							
T_{MIN} to T_{MAX}	-1.5		+10	-1.5		+10	V
ACCURACY (Error Relative to Full Scale) +25°C		$\pm 1/4$ (0.006)	$\pm 1/2$ (0.012)		$\pm 1/8$ (0.003)	$\pm 1/4$ (0.006)	LSB % of F.S. Range
T_{MIN} to T_{MAX}		$\pm 1/2$ (0.012)	$\pm 3/4$ (0.018)		$\pm 1/4$ (0.006)	$\pm 1/2$ (0.012)	LSB % of F.S. Range
DIFFERENTIAL NONLINEARITY +25°C		$\pm 1/2$	$\pm 3/4$		$\pm 1/4$	$\pm 1/2$	LSB
T_{MIN} to T_{MAX}		MONOTONICITY GUARANTEED			MONOTONICITY GUARANTEED		
TEMPERATURE COEFFICIENTS							
Unipolar Zero		1	2		1	2	ppm/°C
Bipolar Zero		5	10		5	10	ppm/°C
Gain (Full Scale)		7	10		3	5	ppm/°C
Differential Nonlinearity		2			2		ppm/°C
SETTLING TIME TO 1/2 LSB All Bits ON-to-OFF or OFF-to-ON (Figure 8)		250	350		250	350	ns
FULL-SCALE TRANSITION							
10% to 90% Delay plus Rise Time		15	30		15	30	ns
90% to 10% Delay plus Fall Time		30	50		30	50	ns
POWER REQUIREMENTS							
V_{EE} , -11.4 to -16.5 V dc		-12	-18		-12	-18	mA
POWER SUPPLY GAIN SENSITIVITY ² $V_{EE} = -11.4$ to -16.5 V dc		15	25		15	25	ppm of F.S./%
PROGRAMMABLE OUTPUT RANGES (see Figures 3, 4, 5)		0 to +5 -2.5 to +2.5	0 to +10 -5 to +5 -10 to +10		0 to +5 -2.5 to +2.5 0 to +10 -5 to +5 -10 to +10		V V V V V
EXTERNAL ADJUSTMENTS							
Gain Error with Fixed 50 Ω Resistor for R_2 (Figure 3)		± 0.1	± 0.25		± 0.1	± 0.25	% of F.S. Range
Bipolar Zero Error with Fixed 50 Ω Resistor for R_1 (Figure 4)		± 0.05	± 0.15		± 0.05	± 0.1	% of F.S. Range
Gain Adjustment Range (Figure 3)	± 0.25			± 0.25			% of F.S. Range
Bipolar Zero Adjustment Range	± 0.15			± 0.15			% of F.S. Range
REFERENCE INPUT							
Input Impedance	15k	20k	25k	15k	20k	25k	Ω
POWER DISSIPATION		180	300		180	300	mW
MULTIPLYING MODE PERFORMANCE (All Models)		Two (2): Bipolar Operation at Digital Input Only +1 V to +10 V, Unipolar 10 Bits ($\pm 0.05\%$ of Reduced F.S.) for 1 V dc Reference Voltage					
Quadrants							
Reference Voltage							
Accuracy							
Reference Feedthrough (Unipolar Mode, All Bits OFF, and 1 V to +10 V [p-p], Sinewave Frequency for 1/2 LSB [p-p] Feedthrough)		40 kHz typ					
Output Slew Rate 10%-90%		5 mA/ μs					
90%-10%		1 mA/ μs					
Output Settling Time (all Bits on and a 0 V-10 V Step Change in Reference Voltage)		1.5 μs to 0.01% F.S.					
CONTROL AMPLIFIER							
Full Power Bandwidth		300 kHz					
Small-Signal Closed-Loop Bandwidth		1.8 MHz					

NOTES

¹The digital input levels are guaranteed but not tested over the temperature range.

²The power supply gain sensitivity is tested in reference to a V_{EE} of -1.5 V dc.

Specifications subject to change without notice.

AD565A/AD566A

Model	AD566AS			AD566AT			Units
	Min	Typ	Max	Min	Typ	Max	
DATA INPUTS ¹ (Pins 13 to 24) TTL or 5 Volt CMOS							
Input Voltage							
Bit ON Logic "1"	+2.0		+5.5	+2.0		+5.5	V
Bit OFF Logic "0"	0		+0.8	0		+0.8	V
Logic Current (Each Bit)							
Bit ON Logic "1"		+120	+300		+120	+300	μA
Bit OFF Logic "0"		+35	+100		+35	+100	μA
RESOLUTION			12			12	Bits
OUTPUT							
Current							
Unipolar (All Bits On)	-1.6	-2.0	-2.4	-1.6	-2.0	-2.4	mA
Bipolar (All Bits On or Off)	±0.8	±1.0	±1.2	±0.8	±1.0	±1.2	mA
Resistance (Exclusive of Span Resistors)	6k	8k	10k	6k	8k	10k	Ω
Offset							
Unipolar (Adjustable to Zero per Figure 3)		0.01	0.05		0.01	0.05	% of F.S. Range
Bipolar (Figure 4, R ₁ and R ₂ = 50 Ω Fixed)		0.05	0.15		0.05	0.1	% of F.S. Range
Capacitance		25			25		pF
Compliance Voltage T _{MIN} to T _{MAX}	-1.5		+10	-1.5		+10	V
ACCURACY (Error Relative to Full Scale) +25°C							
T _{MIN} to T _{MAX}		±1/4 (0.006)	±1/2 (0.012)		±1/8 (0.003)	±1/4 (0.006)	LSB % of F.S. Range
		±1/2 (0.012)	±3/4 (0.018)		±1/4 (0.006)	±1/2 (0.012)	LSB % of F.S. Range
DIFFERENTIAL NONLINEARITY +25°C T _{MIN} to T _{MAX}		±1/2	±3/4		±1/4	±1/2	LSB
		MONOTONICITY GUARANTEED			MONOTONICITY GUARANTEED		
TEMPERATURE COEFFICIENTS							
Unipolar Zero		1	2		1	2	ppm/°C
Bipolar Zero		5	10		5	10	ppm/°C
Gain (Full Scale)		7	10		3	5	ppm/°C
Differential Nonlinearity					2		ppm/°C
SETTLING TIME TO 1/2 LSB All Bits ON-to-OFF or OFF-to-ON (Figure 8)		250	350		250	350	ns
FULL-SCALE TRANSITION							
10% to 90% Delay plus Rise Time		15	30		15	30	ns
90% to 10% Delay plus Fall Time		30	50		30	50	ns
POWER REQUIREMENTS							
V _{EE} -11.4 to -16.5 V dc		-12	-18		-12	-18	mA
POWER SUPPLY GAIN SENSITIVITY ² V _{EE} = -11.4 to -16.5 V dc		15	25		15	25	ppm of F.S./%
PROGRAMMABLE OUTPUT RANGES (see Figures 3, 4, 5)							
		0 to +5			0 to +5		V
		-2.5 to +2.5			-2.5 to +2.5		V
		0 to +10			0 to +10		V
		-5 to +5			-5 to +5		V
		-10 to +10			-10 to +10		V
EXTERNAL ADJUSTMENTS							
Gain Error with Fixed 50 Ω Resistor for R ₂ (Figure 3)		±0.1	±0.25		±0.1	±0.25	% of F.S. Range
Bipolar Zero Error with Fixed 50 Ω Resistor for R ₁ (Figure 4)		±0.05	±0.15		±0.05	±0.1	% of F.S. Range
Gain Adjustment Range (Figure 3)	±0.25			±0.25			% of F.S. Range
Bipolar Zero Adjustment Range	±0.15			±0.15			% of F.S. Range
REFERENCE INPUT							
Input Impedance	15k	20k	25k	15k	20k	25k	Ω
POWER DISSIPATION		180	300		180	300	mW
MULTIPLYING MODE PERFORMANCE (All Models)		Two (2): Bipolar Operation at Digital Input Only +1 V to +10 V, Unipolar 10 Bits (±0.05% of Reduced F.S.) for 1 V dc Reference Voltage					
Quadrants							
Reference Voltage							
Accuracy							
Reference Feedthrough (Unipolar Mode, All Bits OFF, and 1 V to +10 V [p-p], Sinewave Frequency for 1/2 LSB [p-p] Feedthrough)		40 kHz typ					
Output Slew Rate 10%-90%		5 mA/μs					
90%-10%		1 mA/μs					
Output Settling Time (all Bits ON and a 0 V-10 V Step Change in Reference Voltage)		1.5 μs to 0.01% F.S.					
CONTROL AMPLIFIER							
Full Power Bandwidth		300 kHz					
Small-Signal Closed-Loop Bandwidth		1.8 MHz					

NOTES

Specifications shown in boldface are tested on all production units at final electrical test. Results from those tests are used to calculate outgoing quality levels. All min and max specifications are guaranteed, although only those shown in boldface are tested on all production units. Specification subject to change without notice.

AD565A/AD566A

ABSOLUTE MAXIMUM RATINGS

V _{CC} to Power Ground	0 V to +18 V
V _{EE} to Power Ground (AD565A)	0 V to -18 V
Voltage on DAC Output (Pin 9)	-3 V to +12 V
Digital Inputs (Pins 13 to 24) to	
Power Ground	-1.0 V to +7.0 V
REF IN to Reference Ground	±12 V
Bipolar Offset to Reference Ground	±12 V
10 V Span R to Reference Ground	±12 V
20 V Span R to Reference Ground	±24 V
REF OUT (AD565A)	Indefinite Short to Power Ground
	Momentary Short to V _{CC}
Power Dissipation	1000 mW

AD565A ORDERING GUIDE

Model ¹	Max Gain T.C. (ppm of F.S./°C)	Temperature Range	Linearity Error Max @ +25°C	Package Option ²
AD565AJD	50	0°C to +70°C	±1/2 LSB	Ceramic (D-24)
AD565AJR	50	0°C to +70°C	±1/2 LSB	SOIC (R-28)
AD565AKD	20	0°C to +70°C	±1/4 LSB	Ceramic (D-24)
AD565ASD	30	-55°C to +125°C	±1/2 LSB	Ceramic (D-24)
AD565ATD	15	-55°C to +125°C	±1/4 LSB	Ceramic (D-24)

NOTES

¹For details on grade and package offerings screened in accordance with MIL-STD-883, refer to the Analog Devices Military Products Databook or current/883B data sheet.

²D = Ceramic DIP, R = SOIC.

AD566A ORDERING GUIDE

Model ¹	Max Gain T.C. (ppm of F.S./°C)	Temperature Range	Linearity Error Max @ +25°C	Package Option ²
AD566AJD	10	0°C to +70°C	±1/2 LSB	Ceramic (D-24)
AD566AKD	3	0°C to +70°C	±1/4 LSB	Ceramic (D-24)
AD566ASD	10	-55°C to +125°C	±1/2 LSB	Ceramic (D-24)
AD566ATD	3	-55°C to +125°C	±1/4 LSB	Ceramic (D-24)

NOTES

¹For details on grade and package offerings screened in accordance with MIL-STD-883, refer to the Analog Devices Military Products Databook or current/883B data sheet.

²D = Ceramic DIP.

GROUNDING RULES

The AD565A and AD566A bring out separate reference and power grounds to allow optimum connections for low noise and high-speed performance. These grounds should be tied together at one point, usually the device power ground. The separate ground returns are provided to minimize current flow in low-level signal paths. In this way, logic return currents are not summed into the same return path with analog signals.

CONNECTING THE AD565A FOR BUFFERED VOLTAGE OUTPUT

The standard current-to-voltage conversion connections using an operational amplifier are shown here with the preferred trimming techniques. If a low offset operational amplifier (AD510L, AD517L, AD741L, AD301AL, AD OP07) is used, excellent performance can be obtained in many situations without trimming (an op amp with less than 0.5 mV max offset voltage should be used to keep offset errors below 1/2 LSB). If a 50 Ω fixed resistor is substituted for the 100 Ω trimmer, unipolar zero will typically be within ±1/2 LSB (plus op amp offset), and full-scale accuracy will be within 0.1% (0.25% max).

Substituting a 50 Ω resistor for the 100 Ω bipolar offset trimmer will give a bipolar zero error typically within ±2 LSB (0.05%).

The AD509 is recommended for buffered voltage-output applications which require a settling time to ±1/2 LSB of one microsecond. The feedback capacitor is shown with the optimum value for each application; this capacitor is required to compensate for the 25 picofarad DAC output capacitance.

PIN DESIGNATIONS

24-Pin DIP

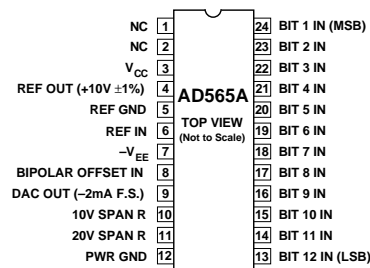

28-Pin SOIC

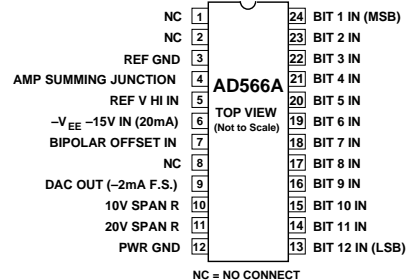

28-Pin SOIC

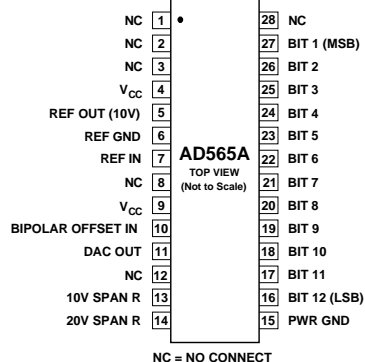

FIGURE 1. UNIPOLAR CONFIGURATION

This configuration will provide a unipolar 0 volt to +10 volt output range. In this mode, the bipolar terminal, Pin 8, should be grounded if not used for trimming.

STEP I . . . ZERO ADJUST

Turn all bits OFF and adjust zero trimmer R1, until the output reads 0.000 volts (1 LSB = 2.44 mV). In most cases this trim is not needed, but Pin 8 should then be connected to Pin 12.

STEP II . . . GAIN ADJUST

Turn all bits ON and adjust 100 Ω gain trimmer R2, until the output is 9.9976 volts. (Full scale is adjusted to 1 LSB less than nominal full scale of 10.000 volts.) If a 10.2375 V full scale is desired (exactly 2.5 mV/bit), insert a 120 Ω resistor in series with the gain resistor at Pin 10 to the op amp output.

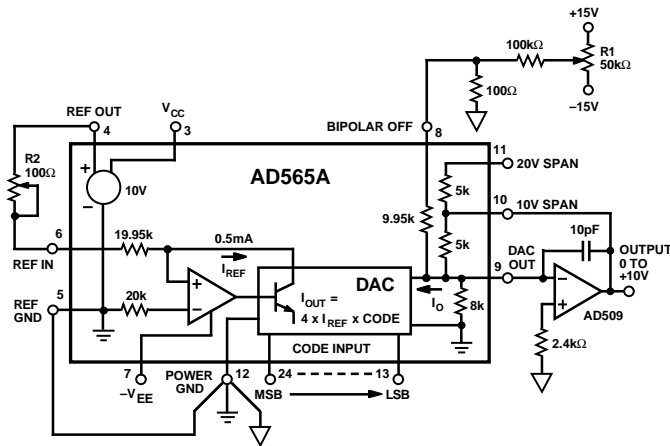

Figure 1. 0 V to +10 V Unipolar Voltage Output

FIGURE 2. BIPOLAR CONFIGURATION

This configuration will provide a bipolar output voltage from -5.000 to +4.9976 volts, with positive full scale occurring with all bits ON (all 1s).

STEP I . . . OFFSET ADJUST

Turn OFF all bits. Adjust 100 Ω trimmer R1 to give -5.000 volts output.

STEP II . . . GAIN ADJUST

Turn ON All bits. Adjust 100 Ω gain trimmer R2 to give a reading of +4.9976 volts.

Please note that it is not necessary to trim the op amp to obtain full accuracy at room temperature. In most bipolar situations, an op amp trim is unnecessary unless the untrimmed offset drift of the op amp is excessive.

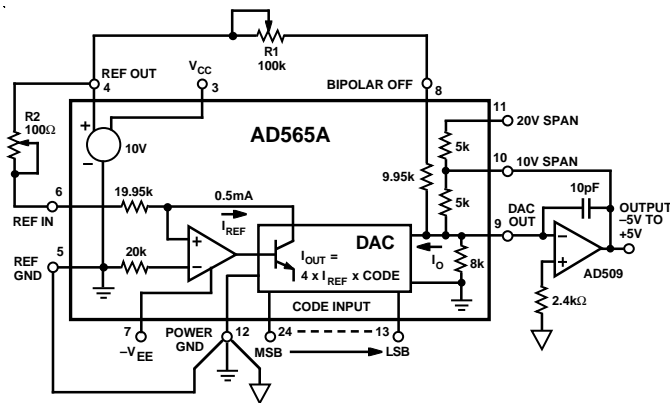

Figure 2. ±5 V Bipolar Voltage Output

FIGURE 3. OTHER VOLTAGE RANGES

The AD565A can also be easily configured for a unipolar 0 volt to +5 volt range or ±2.5 volt and ±10 volt bipolar ranges by using the additional 5k application resistor provided at the 20 volt span R terminal, Pin 11. For a 5 volt span (0 to +5 or ±2.5), the two 5k resistors are used in parallel by shorting Pin 11 to Pin 9 and connecting Pin 10 to the op amp output and the bipolar offset either to ground for unipolar or to REF OUT for the bipolar range. For the ±10 volt range (20 volt span) use the 5k resistors in series by connecting only Pin 11 to the op amp output and the bipolar offset connected as shown. The ±10 volt option is shown in Figure 3.

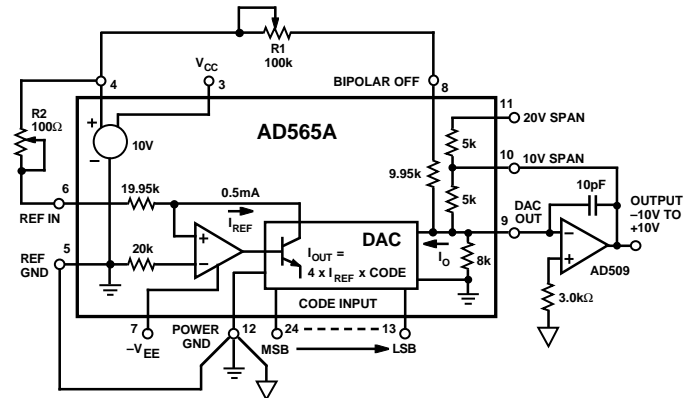

Figure 3. ±10 V Voltage Output

CONNECTING THE AD566A FOR BUFFERED VOLTAGE OUTPUT

The standard current-to-voltage conversion connections using an operational amplifier are shown here with the preferred trimming techniques. If a low offset operational amplifier (AD510L, AD517L, AD741L, AD301AL, AD OP07) is used, excellent performance can be obtained in many situations without trimming (an op amp with less than 0.5 mV max offset voltage should be used to keep offset errors below 1/2 LSB). If a 50 Ω fixed resistor is substituted for the 100 Ω trimmer, unipolar zero will typically be within ±1/2 LSB (plus op amp offset), and full scale accuracy will be within 0.1% (0.25% max). Substituting a 50 Ω resistor for the 100 Ω bipolar offset trimmer will give a bipolar zero error typically within ±2 LSB (0.05%).

The AD509 is recommended for buffered voltage-output applications which require a settling time to ±1/2 LSB of one microsecond. The feedback capacitor is shown with the optimum value for each application; this capacitor is required to compensate for the 25 picofarad DAC output capacitance.

FIGURE 4. UNIPOLAR CONFIGURATION

This configuration will provide a unipolar 0 volt to +10 volt output range. In this mode, the bipolar terminal, Pin 7, should be grounded if not used for trimming.

STEP I . . . ZERO ADJUST

Turn all bits OFF and adjust zero trimmer, R1, until the output reads 0.000 volts (1 LSB = 2.44 mV). In most cases this trim is not needed, but Pin 7 should then be connected to Pin 12.

STEP II . . . GAIN ADJUST

Turn all bits ON and adjust 100 Ω gain trimmer, R2, until the output is 9.9976 volts. (Full scale is adjusted to 1 LSB less than nominal full scale of 10.000 volts.) If a 10.2375 V full scale is desired (exactly 2.5 mV/bit), insert a 120 Ω resistor in series with the gain resistor at Pin 10 to the op amp output.

AD565A/AD566A

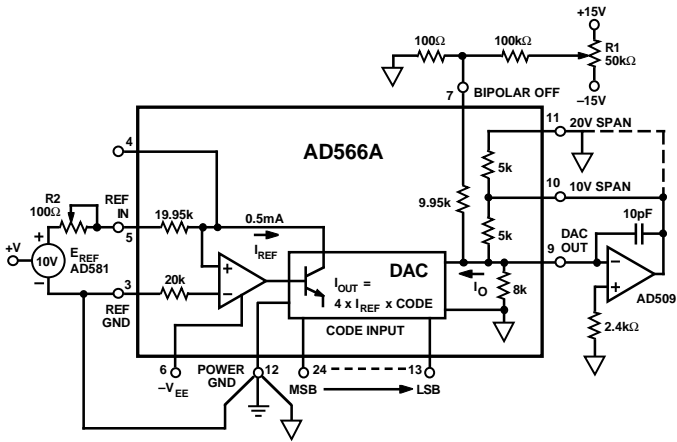

Figure 4. 0 V to +10 V Unipolar Voltage Output

FIGURE 5. BIPOLAR CONFIGURATION

This configuration will provide a bipolar output voltage from -5.000 volts to +4.9976 volts, with positive full scale occurring with all bits ON (all 1s).

STEP I . . . OFFSET ADJUST

Turn OFF all bits. Adjust 100 Ω trimmer R1 to give -5.000 output volts.

STEP II . . . GAIN ADJUST

Turn ON all bits. Adjust 100 Ω gain trimmer R2 to give a reading of +4.9976 volts.

Please note that it is not necessary to trim the op amp to obtain full accuracy at room temperature. In most bipolar situations, an op amp trim is unnecessary unless the untrimmed offset drift of the op amp is excessive.

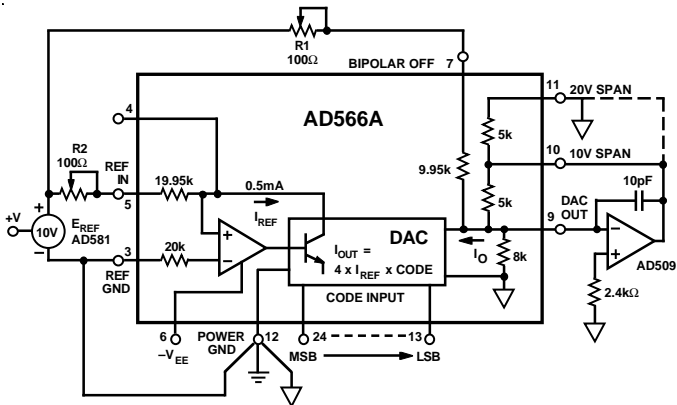
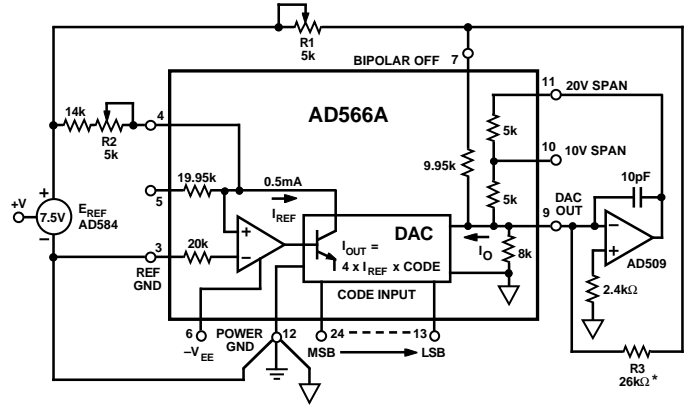

Figure 5. ±5 V Bipolar Voltage Output

FIGURE 6. OTHER VOLTAGE RANGES

The AD566A can also be easily configured for a unipolar 0 volt to +5 volt range or ±2.5 volt and ±10 volt bipolar ranges by using the additional 5k application resistor provided at the 20 volt span R terminal, Pin 11. For a 5 volt span (0 V to +5 V or ±2.5 V), the two 5k resistors are used in parallel by shorting Pin 11 to Pin 9 and connecting Pin 10 to the op amp output and the bipolar offset resistor either to ground for unipolar or to V_{REF} for the bipolar range. For the ±10 volt range (20 volt span) use the 5k resistors in series by connecting only Pin 11 to the op amp output and the bipolar offset connected as shown. The ±10 volt option is shown in Figure 6.



* THE PARALLEL COMBINATION OF THE BIPOLAR OFFSET RESISTOR AND R3 ESTABLISH A CURRENT TO BALANCE THE MSB CURRENT. THE EFFECT OF TEMPERATURE COEFFICIENT MISMATCH BETWEEN THE BIPOLAR RESISTOR COMBINATION AND DAC RESISTORS IS EXPANDED ON PREVIOUS PAGE.

Figure 6. ±10 V Voltage Output

Table I. Digital Input Codes

DIGITAL INPUT		ANALOG OUTPUT		
MSB	LSB	Straight Binary	Offset Binary	Twos Compl.*
0	0	Zero	-FS	Zero
0	1	Mid Scale - 1 LSB	Zero - 1 LSB	+FS - 1 LSB
1	0	+1/2 FS	Zero	-FS
1	1	+FS - 1 LSB	+ FS - 1 LSB	Zero - 1 LSB

*Inverts the MSB of the offset binary code with an external inverter to obtain twos complement.

OUTLINE DIMENSIONS

Dimensions shown in inches and (mm).

Ceramic DIP (D-24)

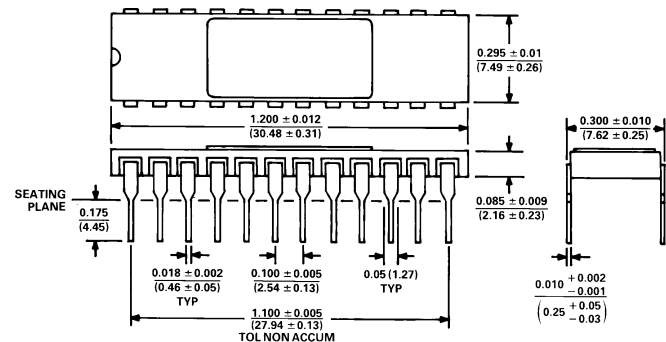

- NOTES
 1. LEAD NO. 1 IDENTIFIED BY DOT OR NOTCH.
 2. CERAMIC DIP LEADS WILL BE EITHER GOLD OR TIN PLATED IN ACCORDANCE WITH MIL-M-385 TO REQUIREMENTS.
 3. METAL LID IS CONNECTED TO DGND.

SOIC (R-28) Package

