

HEXFET® POWER MOSFET PHOTOVOLTAIC RELAY

Series PVT422

Microelectronic
Power IC Relay
Dual Pole, Normally Open
0-400V, 120mA AC/DC

General Description

The PVT422 Series Photovoltaic Relay is a dual-pole, normally open solid-state relay that can replace electromechanical relays in many applications. It utilizes International Rectifier's HEXFET power MOSFET as the output switch, driven by an integrated circuit photovoltaic generator of novel construction. The output switch is controlled by radiation from a GaAlAs light emitting diode (LED) which is optically isolated from the photovoltaic generator.

Series PVT422 Relays are packaged in an 8-pin, molded DIP package with either thru-hole or "gull-wing" surface mount terminals. It is available in standard plastic shipping tubes or on tape-and-reel. Refer to Part Identification information.

Applications

- On/Off Hook switch ■
- Dial-Out relay ■
- Ring injection relay ■
- General switching ■

PVT422 Features

- HEXFET Power MOSFET output ■
- Bounce-free operation ■
- 4,000 V_{RMS} I/O isolation ■
- Linear AC/DC operation ■
- Solid-State reliability ■
- UL recognition and CSA certification pending ■

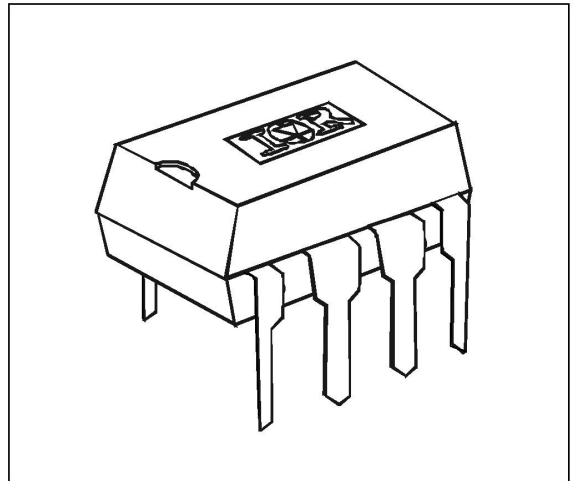

Part Identification

PVT422	thru-hole
PVT422S	SMT
PVT422S-T	SMT, T&R

(HEXFET is the registered trademark for International Rectifier Power MOSFETs)

Series PVT422

Electrical Specifications (-40°C ≤ T_A ≤ +85°C unless otherwise specified)

INPUT CHARACTERISTICS	Limits	Units
Min. Control Current (See Fig.1)	2.0	mA
Max. Control Current for Off-State Resistance @ T _A =+25°C	0.4	mA
Control Current Range (Caution: current limit input LED, see Fig.5)	2.0 to 25	mA
Max. Reverse Voltage	7.0	V

OUTPUT CHARACTERISTICS	Limits	Units
Operating Voltage Range	0 to ±400	V(DC or AC peak)
Max. Load Current @ T _A =+40°C 5mA Control (See Fig.1) (single and dual channel operation)	120	mA
Max. Peak Load Current (10ms max. duration) (single and dual channel operation)	350	mA
Max. On-State Resistance @ T _A =+25°C For 50mA Pulsed Load, 5mA Control (See Fig.3)	35	Ω
Max. Off-State Leakage @ T _A =+25°C, ±320V (See Fig.4)	1.0	μA
Max. Turn-On Time @ T _A =+25°C (See Fig. 6) For 50mA, 100 V _{DC} Load, 5mA Control	2.0	ms
Max. Turn-Off Time @ T _A =+25°C (See Fig. 6) For 50mA, 100 V _{DC} Load, 5mA Control	2.0	ms
Max. Output Capacitance @ 50V _{DC}	12	pF

GENERAL CHARACTERISTICS	Limits	Units
Min. Dielectric Strength, Input-Output	4000	V _{RMS}
Min. Dielectric Strength, Pole-to-Pole	1000	V _{DC}
Min. Insulation Resistance, Input-Output @ T _A =+25°C, 50%RH, 100V _{DC}	10 ¹²	Ω
Max. Capacitance, Input-Output	1.0	pF
Max. Pin Soldering Temperature (10 seconds max.)	+260	
Ambient Temperature Range: Operating	-40 to +85	°C
Storage	-40 to +100	

Connection Diagram

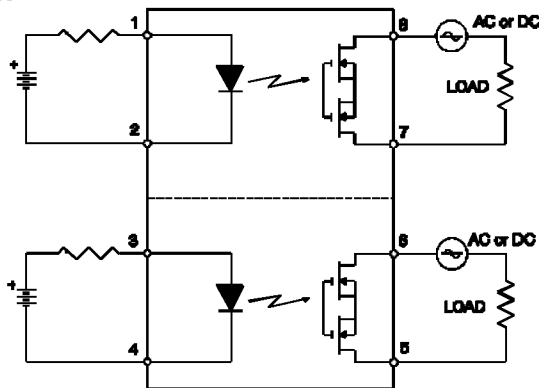

Series PVT422

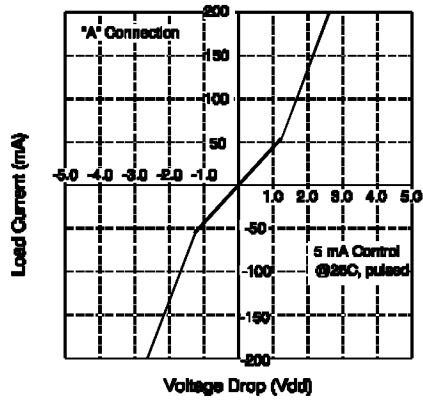

Figure 2. Linearity Characteristics

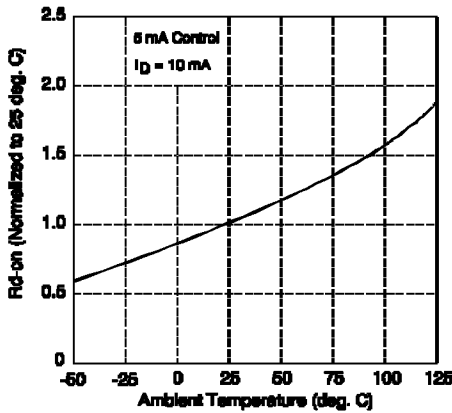

Figure 3. Typical Normalized On-Resistance

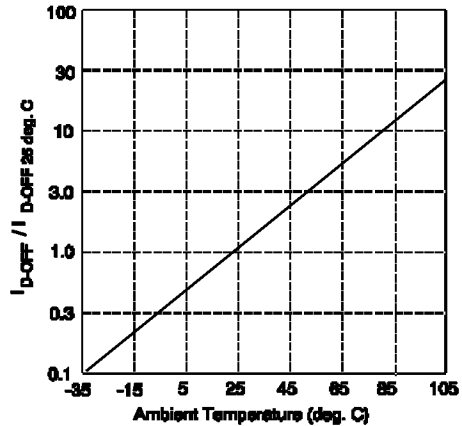

Figure 4. Typical Normalized Off-State Leakage

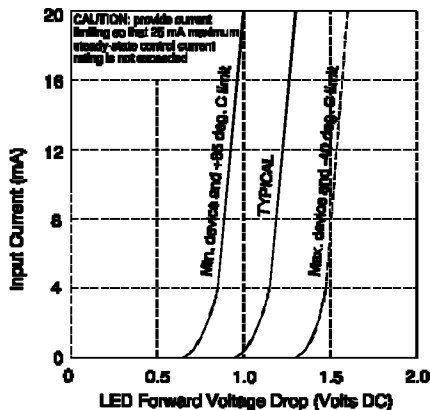

Figure 5. Input Characteristics (Current Controlled)

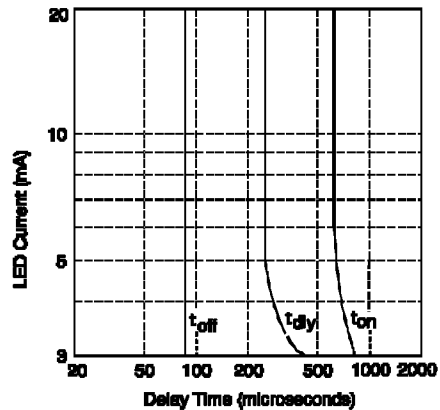

Figure 6. Typical Delay Times

Series PVT422

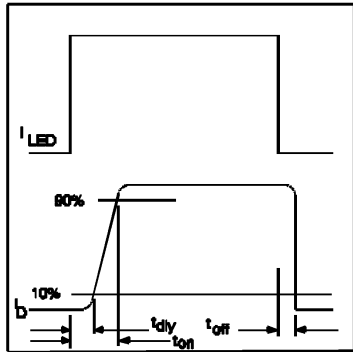

Figure 7. Delay Time Definitions

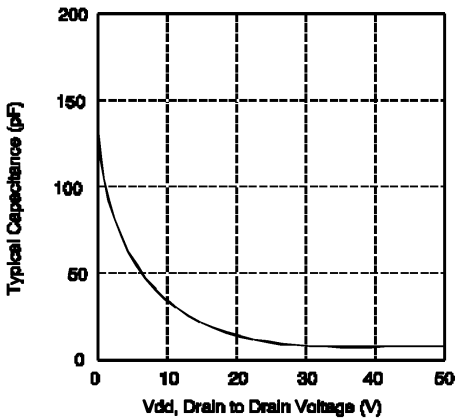
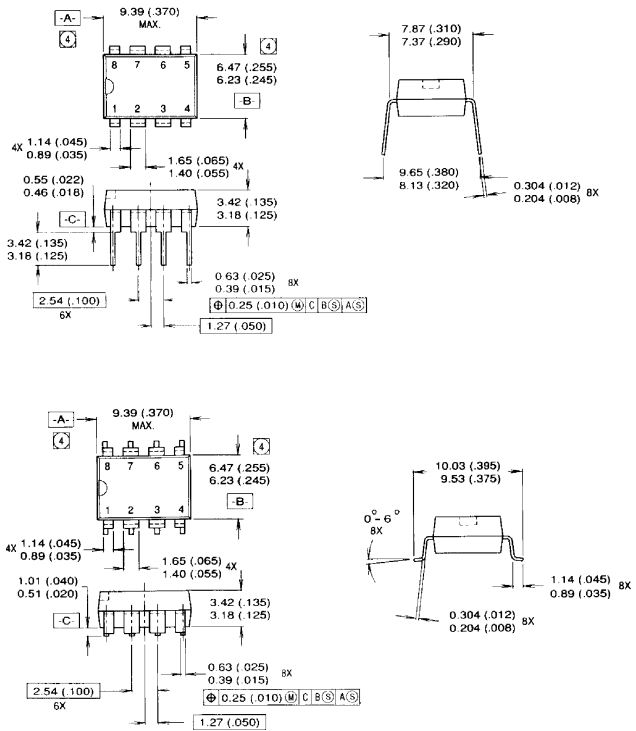

Figure 8. Typical Output Capacitance

Mechanical Specifications

(Dimensions in millimeters (inches))



1. DIMENSIONING AND TOLERANCING PER ANSI Y14.5M-1982
 2. CONTROLLING DIMENSION: INCH
- ④ DIMENSION DOES NOT INCLUDE MOLD PROTRUSIONS. MOLD PROTRUSIONS SHALL NOT EXCEED 0.25 (.010).

WORLD HEADQUARTERS: 233 Kansas St., El Segundo, California 90245, Tel: (310) 322 3331
 EUROPEAN HEADQUARTERS: Hurst Green, Oxted, Surrey RH8 9BB, UK Tel: ++ 44 1883 713215

IR CANADA: 7321 Victoria Park Ave., Suite 201, Markham, Ontario L3R 2Z8, Tel: (905) 475 1897

IR GERMANY: Saalburgstrasse 157, 61350 Bad Homburg Tel: ++ 49 6172 96590

IR ITALY: Via Liguria 49, 10071 Borgaro, Torino Tel: ++ 39 11 451 0111

IR FAR EAST: K&H Bldg., 2F, 3-30-4 Nishi-Ikeburo 3-Chome, Toshima-Ku, Tokyo, Japan 171 Tel: ++ 81 3 3983 0641

IR SOUTHEAST ASIA: 315 Outram Road, #10-02 Tan Boon Liat Building, Singapore 0316 Tel: ++ 65 221 8371

Data and specifications subject to change without notice. 9/95